

1902 - Serving Our Community for over 120 Years - 2023

WEST BAY SANITARY DISTRICT

AGENDA OF BUSINESS

REGULAR MEETING OF THE DISTRICT BOARD

WEDNESDAY, JANUARY 25, 2023 AT 7:00 P.M.

RONALD W. SHEPHERD ADMINISTRATION BUILDING,
500 LAUREL STREET, MENLO PARK, CALIFORNIA 94025

Board Members

Fran Dehn, President
David Walker, Secretary
Roy Thiele-Sardiña, Treasurer
Edward P. Moritz, Member
George Otte, Member

General Manager

Sergio Ramirez

District General Counsel

Anthony Condotti, Esq.

AGENDA OF BUSINESS

NOTICE OF PUBLIC PARTICIPATION BY TELECONFERENCE or ZOOM ONLY

Pursuant to California Assembly Bill 361, members of the West Bay Sanitary District Board of Directors and Staff may participate in this meeting via a teleconference. In the interest of reducing the spread of COVID- 19, members of the public are allowed to participate telephonically only, and may submit comments in advance by email addressed to info@westbaysanitary.org by 4:00 p.m. on Wednesday, January 25th.

To participate by telephone or Zoom meeting, public comments can be made by joining Zoom meeting at:

<https://us06web.zoom.us/j/82974980931?pwd=YzRqYUp2Y1NIL2VWQUJ2bHVsaVdiQT09>

Meeting ID: 829 7498 0931 Passcode: 519163 or by phone, call: 1-669-900-6833

Meeting ID: 829 7498 0931 Passcode: 519163

Following receipt of public comment and open session items, the Board will adjourn to closed session. Reportable action, if any, will be available upon inquiry within twenty-four (24) hours.

NOTE: The Board may take action on any agendized item unless specifically designated a "discussion" item or a "report."

1. Call to Order and Roll Call
2. Communications from the Public
3. Consent Calendar

Matters listed under this item are considered routine and will be enacted by one motion. The motion, seconds, and vote are applicable to any included resolutions and recorded accordingly. There will be no separate discussion of these items unless specifically requested by a member of the Board.

- A. Approval of Minutes for Regular meeting January 11, 2023 Pg. 3A-1

- B. Consider Resolution Accepting Deed of Easement Pursuant to Class 3 Sewer Permit No. 1610 for the Construction of Wastewater Facilities for 130 Shawnee Pass Portola Valley, California Pg. 3B-1
 - C. Consider Accepting Sewer Facilities Constructed Pursuant to Class 3 Sewer Permit No. 1610 for the Construction of Wastewater Facilities for 130 Shawnee Pass, Portola Valley, California Pg. 3C-1
 - D. Consider Resolution Accepting Deed of Easement Pursuant to Class 3 Sewer Permit No. 1037 for the Construction of Wastewater Facilities for 3899 Alpine Road, Portola Valley, California Pg. 3D-1
 - E. Consider Accepting Sewer Facilities Constructed Pursuant to Class 3 Sewer Permit No. 1037 for the Construction of Wastewater Facilities for 3899 Alpine Road, Portola Valley, California Pg. 3E-1
- 4. General Manager's Report Pg. 4-1
 - 5. Presentation & Discussion on the Pump Station Integrated Systems and Control (ISAC) Pg. 5-1
 - 6. Consider Approving District Treasury Report Second Quarter FY 2022-23 Pg. 6-1
 - 7. Consider Establishing February 8, 2023 as the Date of Public Hearing to Consider a Board Member Compensation General Regulation Amending the Code of General Regulations Pg. 7-1
 - 8. Discussion and Direction on Sharon Heights Recycled Water Plant Pg. 8-1
 - 9. Discussion and Direction on Bayfront Recycled Water Project and Status Update Pg. 9-1
 - 10. Report and Discussion on South Bayside Waste Management Authority (SBWMA) Pg. 10-1
 - 11. Report and Discussion on Silicon Valley Clean Water (SVCW) Plant Pg. 11-1
 - 12. Closed Session:
 - A. PUBLIC EMPLOYEE PERFORMANCE EVALUATION/CONF. WITH LABOR NEGOTIATORS
Agency designated representatives: Board President/General Counsel
Unrepresented employee: General Manager
 - 13. Comments or Reports from Members of the District Board and Consider Items to be Placed on Future Agenda
 - 14. Adjournment

The West Bay Sanitary District does not discriminate against persons with disabilities. Upon request, the agenda and agenda packet can be provided in a format to accommodate special needs. If you require a copy of the agenda or related materials in an alternative format to accommodate a disability, or if you wish to attend this public meeting and will require special assistance or other special equipment, please call the District at (650) 321-0384 at least five days in advance and we will make every reasonable attempt to provide such an accommodation.



1902 - Serving Our Community for over 115 Years - 2023

**WEST BAY SANITARY DISTRICT
MINUTES OF THE REGULAR MEETING OF THE DISTRICT BOARD
WEDNESDAY, JANUARY 11, 2023 AT 7:00 P.M.**

1. Call to Order

President Dehn called the meeting to order at 7:00 PM

Roll Call

BOARD MEMBERS PRESENT: President Dehn, Secretary Walker, Treasurer Thiele-Sardiña, Director Moritz, Director Otte
BOARD MEMBERS ABSENT: None
STAFF MEMBERS PRESENT: Ramirez, Condotti by Zoom
Others Present: Vivian Housen – V.W. Housen & Associates; Eileen McLaughlin - CCCR

2. Communications from the Public: None.

3. Consent Calendar

CONSIDERATION OF ITEM(S) REMOVED FROM THE CONSENT CALENDAR

Discussion/Comments: None.

- A. Approval of Minutes for Regular meeting December 14, 2022
- B. Approval of the Financial Activity Report Authorizing Payment of Certain Bills and Salaries and Consideration of Other Financial Matters thru December 31, 2022
- C. WBSD Operations and Maintenance Report – December 2022
- D. Town of Los Altos Hills Operations and Maintenance Report for Work Performed by WBSD – December 2022
- E. Town of Woodside Operations and Maintenance Report for Work Performed by WBSD – December 2022
- F. Consider Approval of Resolution Authorizing District to Implement Teleconferenced Public Meetings Pursuant to Assembly Bill 361

Motion to Approve by: Thiele-Sardiña 2nd by: Moritz Vote: AYE: 5 NAY: 0 Abstain: 0

4. General Manager's Report

Discussion/Comments: General Manager Ramirez reported flow monitoring began in November of 2022 and we are expecting good results due to the amount of rain. He reported the annual Waste Discharge Requirement permit from the State has been paid in the amount of \$18,500.00. He also reported the Bayfront Park Sewer Improvement project has been awarded to Ranger Pipeline and construction will begin within a month. He informed the Board recruitment for Associate Engineer will begin shortly. He continued to report a \$20K deposit has been collected for the 1125 O'Brien project for a capacity study on the Willow Road Pump Station. General Manager Ramirez reported the first payment of \$15M in sewer service charges has been received by the San Mateo County Controller's office. He also reported IT is migrating accounting and email software to the cloud. The next regular meetings are January 25th and February 8th. Lastly, General Manager Ramirez reported on the storm response by staff. He discussed with the Board in detail the SSO on Ivy Drive and the performance of the Menlo Park Pump Station which is serviced by SVCW. Board consensus was to notify SVCW and strongly recommend that the valves to the Flow Equalization Facility (FEF) remain automated in order to swiftly move flow to the FEF and that an FEF flow meter be installed during the station upgrade to avoid future SSOs. The complete General Manager's written report is in the January 11th, 2023 agenda packet.

5. Consider Authorizing General Manager to Enter into an Agreement for the District's 2023 Master Plan with V.W. Housen & Associates

Motion to Approve by: Walker 2nd by: Otte Vote: AYE: 5 NAY: 0 Abstain: 0

Discussion/Comments: General Manager Ramirez reported the Master Plan Committee met to review the RFPs for the 2023 Master Plan. The Committee recommended the Board select V.W. Housen & Associates who scored highest and was the best value.

6. January 11th Update Report on District Response to Corona Virus

Discussion/Comments: General Manager Ramirez reported the District is working with General Counsel to update the COVID-19 policy to include new CDC guidelines.

7. Report and Discussion on Sharon Heights Recycled Water Plant

Discussion/Comments: General Manager Ramirez reported the plant treated 5.4 MGD and delivered 155,000 gallons in December. He also reported that design is underway for the Avy Altschul pump station.

8. Discussion and Direction on Bayfront Recycled Water Project and Status Update

Discussion/Comments: General Manager Ramirez reported soil samples will be taken for the levee project by Vista Point. He also reported General Counsel is preparing a project management agreement with Meta to begin the construction design of the recycled water facility. The Board agreed by consensus to execute an agreement with Meta for the Project Management of the recycled water facility.

9. Report & Discussion on South Bayside Waste Management Authority (SBWMA)

Discussion/Comments: None.

10. Report, Discussion & Direction on Silicon Valley Clean Water (SVCW) and Discussion on SVCW CIP Program and Financing

Discussion/Comments: Director Otte reported the long range financial plan was presented to and approved by the Commission.

11. Closed Session

Entered closed session at 8:27 p.m. Left closed session at 8:58 p.m.

A. PUBLIC EMPLOYEE PERFORMANCE EVALUATION/CONF. WITH LABOR NEGOTIATORS

Agency designated representatives: Board President/Legal Counsel
Unrepresented employee: General Manager

B. PUBLIC EMPLOYMENT/CONFERENCE WITH LABOR NEGOTIATORS

Agency Designated Representatives: Sergio Ramirez; Tony Condotti
Employees: All Represented and Unrepresented Employees

C. Property: 1101 Altschul Avenue

Agency negotiator: General Manager/General Counsel
Negotiating parties: District and Los Lomitas Elementary School District
Under negotiation: Price/terms of payment for Avy Altschul Pump Station Easement

Reportable action: General Counsel Condotti reported no reportable action on items B & C. On item A the Board gave direction to move into open session to consider end-of-year performance compensation for the General Manager in the amount of 15% of base salary or \$34,800.

12. Consider to Approve End-of-Year Goals and Objectives Performance Compensation for the General Manager

Motion to Approve by: Thiele-Sardiña 2nd by: Moritz Vote: AYE: 5 NAY: 0 Abstain: 0

Discussion/Comments: None.

13. Comments or Reports from Members of the District Board and Consider Items to be Placed on Future Agenda

Discussion/Comments: None.

14. Adjournment Time: The meeting was adjourned at 9:00 PM

THIS PAGE LEFT INTENTIONALLY BLANK



**WEST BAY SANITARY DISTRICT
AGENDA ITEM 3B**

To: Board of Directors

From: Todd Reese, Office & Communications Manager

Subject: Consider Resolution Accepting Deed of Easement Pursuant to Class 3 Sewer Permit No. 1610 for the Construction of Wastewater Facilities for 130 Shawnee Pass, Portola Valley, California

Background

The District requires an easement to maintain the flow from the Grinder system that serves 130 Shawnee Pass. The easement includes ingress and egress to the location of the Grinder system and is conforming to District specifications.

Recommendation

The Office & Communications Manager recommends that the Board adopt the attached Resolution accepting the Deed of Easement.

Attachments: Resolution ____ (2023), Grant Deed of Easement

RESOLUTION NO. _____ (2023)

IN THE DISTRICT BOARD OF THE WEST BAY SANITARY DISTRICT

COUNTY OF SAN MATEO, STATE OF CALIFORNIA

BE IT RESOLVED that the President and Secretary of the West Bay Sanitary District be and are hereby authorized to accept the attached Grant Deed of Easement by and between the following parties:

J. Dorian McKelvy & Terese Bray McKelvy

BE IT FURTHER RESOLVED that the General Manager is hereby directed to place the same on record.

Passed and adopted by the District Board of the West Bay Sanitary District at a regular meeting thereof held on the 25th day of January, 2023, by the following vote:

Ayes:

Noes:

Abstain:

Absent:

President of the District Board of the West
Bay Sanitary District of San Mateo County,
State of California

Attest:

Secretary of the District Board of the
West Bay Sanitary District of San Mateo
County, State of California

RECORDING REQUESTED BY:
WEST BAY SANITARY DISTRICT

WHEN RECORDED MAIL TO:
WEST BAY SANITARY DISTRICT
500 LAUREL STREET
MENLO PARK, CA 94025

Title Order No. N/A
Escrow No. N/A
Parcel No. 077-033-040

GRANT DEED OF EASEMENT

THE UNDERSIGNED GRANTOR(S) DECLARE(S):

- DOCUMENTARY TRANSFER TAX is \$0 CITY TAX is \$0
- computed on the full value of the property conveyed, or
- computed on full value less value of liens or encumbrances remaining at the time of sale,
- this is a conveyance of an easement and the consideration and value is less than \$100, R & T 11911.
- Unincorporated area of San Mateo County Town of Portola Valley

FOR A VALUABLE CONSIDERATION, receipt of which is hereby acknowledged, I (we)

J. Dorian McKelvy & Terese Gray McKelvy

hereby GRANT(S) to: WEST BAY SANITARY DISTRICT, A PUBLIC AGENC

an easement to construct, install, maintain, use, repair, remove, replace any and all pipeline, fittings, and related facilities necessary for the operation of a wastewater conveyance system in the area described as follows over the following described real property in the Town of Portola Valley, County of San Mateo, State of California:

LEGAL DESCRIPTION ATTACHED HERETO AS EXHIBITS "A" AND "B" AND MADE A PART HEREOF

Also Known As: 130 Shawnee Pass, Portola Valley, Cal 94028
Assessor's Parcel Number: 077-033-040

Executed on November 16, 2022 at SAN MATEO COUNTY
(City and State)

J. Dorian MCKELVY | [Signature]
Printed Name(s) | Signature(s)

Terese Gray MCKELVY | [Signature]
Printed Name(s) | Signature(s)

STATE OF CALIFORNIA
COUNTY OF San Mateo } ss.

On 11-16-22 before me, Erika Mackenzie, notary
Date | Name and Title of Officer (e.g., "Jane Doe, Notary Public")

personally appeared Terese Gray McKelvy & Dorian McKelvy
Name(s) of Signer(s)

personally known to me (or proved to me on the basis of satisfactory evidence) to be the person(s) whose name(s) is/are subscribed to the within instrument and acknowledged to me that he/she/they executed the same in his/her/their authorized capacity(ies), and that by his/her/their signature(s) on the instrument the person(s), or the entity upon behalf of which the person(s) acted, executed the document.

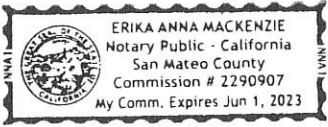

WITNESS my hand and official seal.
Erika Mackenzie
Signature of Notary Public

EXHIBIT "A"
LEGAL DESCRIPTION FOR A
WEST BAY SANITARY DISTRICT
ACCESS EASEMENT
130 SHAWNEE PASS, TOWN OF PORTOLA VALLEY,
SAN MATEO COUNTY, CALIFORNIA

An easement over that certain real property, situate in the Town of Portola Valley, County of San Mateo, State of California, being a portion of Lot 12, as shown on that certain map entitled "Tract No. 761 Arrowhead Meadows Unit No. 2, San Mateo County, California" filed in the office of the County Recorder of San Mateo County on May 29, 1958 in Book 48 of Maps at Pages 48 and 49, said easement more particularly described as follows:

Commencing at the Northeast corner of said Lot 12, said point being on the Westerly right of way line of Shawnee Pass (50' wide);
Thence southerly along said westerly right of way line together with the adjoining Easterly line of said lot, South 03°30'00" East, 11.00 feet to the **Point of Beginning**;
Thence continuing along last said line South 03°30'00" East, 14.00 feet;
Thence leaving last said line, along a line parallel with and 25.00 feet southerly measured at right angles from the Northerly line of said lot, South 86°30'00" West, 94.00 feet;
Thence leaving last said line, South 41°30'00" West, 8.49 feet;
Thence along a line parallel with and 31.00 feet southerly measured at right angles from said northerly line, South 86°30'00" West, 23.00 feet;
Thence leaving last said line, South 03°30'00" East, 9.98 feet;
Thence along a line parallel with and 40.98 feet southerly measured at right angles from said northerly line, South 86°30'00" West, 15.00 feet;
Thence leaving last said line, North 03°30'00" West, 35.98 feet to Southerly line of a Public Utility Easement, 5.00 feet in width, said line being parallel with and 5.00 feet southerly measured at right angles from said northerly line, as shown on said Tract No. 761;
Thence along last said southerly line, North 86°30'00" East, 19.00 feet;
Thence leaving last said line, South 03°30'00" East, 6.00 feet;
Thence along a line parallel with and 11.00 feet southerly measured at right angles from said northerly line, North 86°30'00" East, 119.00 feet to the **Point of Beginning**

Containing 2,884 square feet, more or less.

The bearings shown herein are based on the said Northerly line of Lot 12, "Tract No. 761 Arrowhead Meadows Unit No. 2, San Mateo County, California" filed in the office of the County Recorder of San Mateo County on May 29, 1958 in Book 48 of Maps at Pages 48 and 49 being North 86°30'00" East.

A plat, entitled Exhibit "B", is attached hereto and by this reference made a part hereof.

END OF DESCRIPTION



SHAWNEE PASS (50')

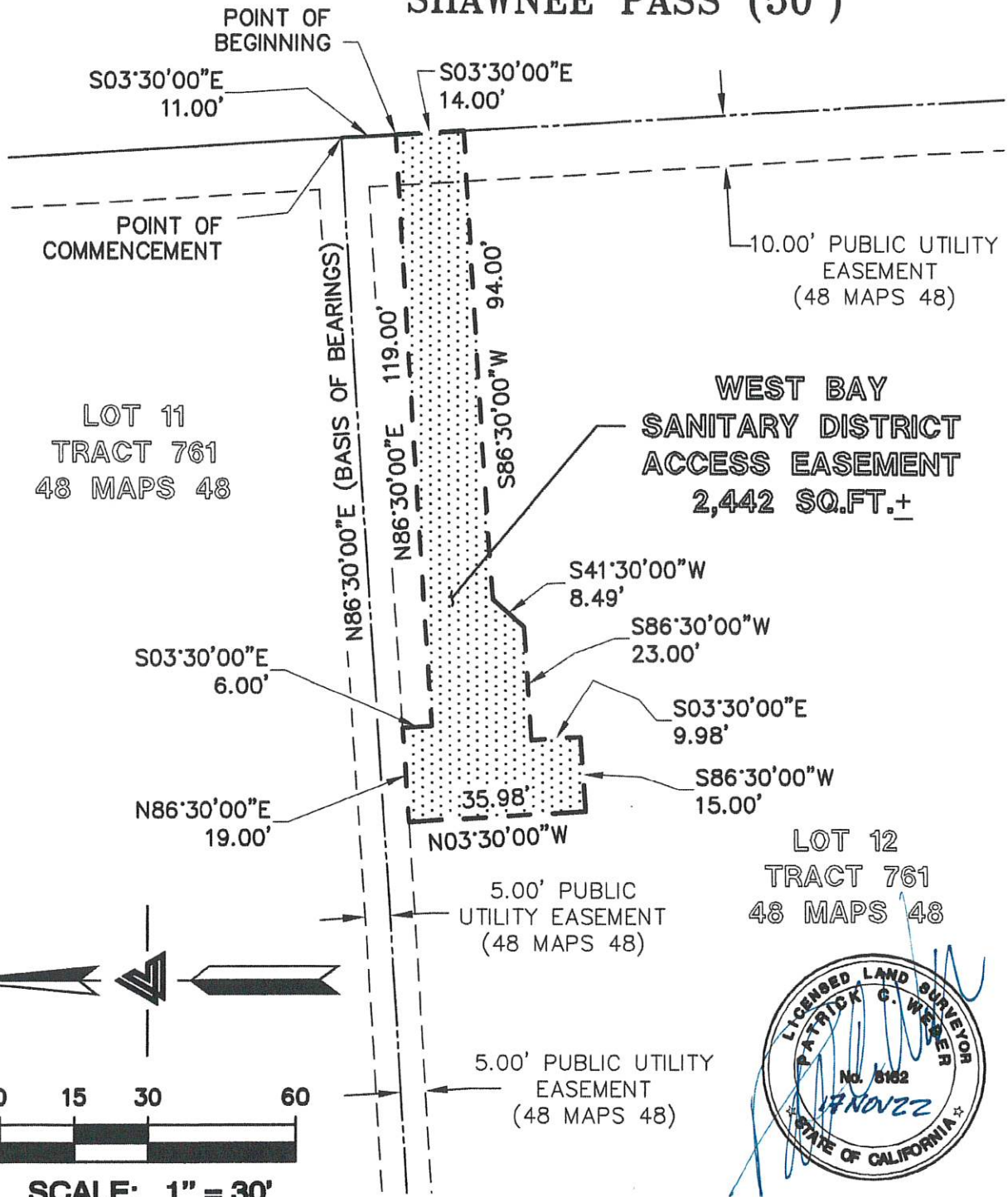

LEA & BRAZE ENGINEERING, INC.

CIVIL ENGINEERS • LAND SURVEYORS

BAY AREA REGION
2495 INDUSTRIAL PKWY WEST
HAYWARD, CALIFORNIA 94545
(P) (510) 887-4086
(F) (510) 887-3019
WWW.LEABRAZE.COM

SACRAMENTO REGION
3017 DOUGLAS BLVD, # 300
ROSEVILLE, CA 95661
(P) (916) 966-1338
(F) (916) 797-7383

EXHIBIT "B" WEST BAY SANITARY DISTRICT ACCESS EASEMENT

130 SHAWNEE PASS, PORTOLA VALLEY
SAN MATEO COUNTY, CALIFORNIA
JOB NO 2101476CI SCALE: 1" = 30'

**CLOSURE CALCULATION
ACCESS EASEMENT
130 SHAWNEE PASS
PORTOLA VALLEY, CALIFORNIA**

JN:2201476CI

DATE: NOVEMBER 2022

North: 5478.7515' East: 9233.3081'

Segment #1 : Line

Course: S03° 30' 00"E Length: 14.00'

North: 5464.7776' East: 9234.1628'

Segment #2 : Line

Course: S86° 30' 00"W Length: 94.00'

North: 5459.0391' East: 9140.3381'

Segment #3 : Line

Course: S41° 30' 00"W Length: 8.49'

North: 5452.6804' East: 9134.7125'

Segment #4 : Line

Course: S86° 30' 00"W Length: 23.00'

North: 5451.2763' East: 9111.7554'

Segment #5 : Line

Course: S03° 30' 00"E Length: 9.98'

North: 5441.3149' East: 9112.3646'

Segment #6 : Line

Course: S86° 30' 00"W Length: 15.00'

North: 5440.3992' East: 9097.3926'

Segment #7 : Line

Course: N03° 30' 00"W Length: 35.98'

North: 5476.3121' East: 9095.1961'

Segment #8 : Line

Course: N86° 30' 00"E Length: 19.00'

North: 5477.4720' East: 9114.1606'

Segment #9 : Line

Course: S03° 30' 00"E Length: 6.00'

North: 5471.4832' East: 9114.5269'

Segment #10 : Line

Course: N86° 30' 00"E Length: 119.00'

North: 5478.7480' East: 9233.3050'

Perimeter: 344.44' Area: 2441.67 Sq. Ft.

Error Closure: 0.0047 Course: S41° 30'
00"W

Error North: -0.00353 East: -0.00313

Precision 1: 73287.23



**WEST BAY SANITARY DISTRICT
AGENDA ITEM 3C**

To: Board of Directors

From: Todd Reese, Office & Communications Manager

Subject: Consider Accepting Sewer Facilities Constructed Pursuant to Class 3 Sewer Permit No. 1610 for the Construction of Wastewater Facilities for 130 Shawnee Pass, Portola Valley, California

Background

This permit request was for the construction of a grinder pump system and force main to serve 130 Shawnee Pass, Portola Valley.

Analysis

The Board issued this permit at the Regular Meeting of October 27, 2021.

The work has been completed and has been inspected, tested, and approved by staff as being in conformance with District standards. The property owner has submitted a one-year guarantee for the work in the form of a maintenance bond.

Recommendation

The Office & Communications Manager recommends that the Board accepts these facilities and directs the General Manager to approve the Class 3 Permit No. 1610.

Attachments: Class 3 Permit No. 1610
Exhibit A: Site map

WEST BAY SANITARY DISTRICT

500 Laurel Street
Menlo Park, California 94025
(650) 321-0384

Permit Number
1610

Type _____

APPLICATION FOR CLASS 3 SEWER PERMIT

To the WEST BAY SANITARY DISTRICT:

The undersigned, being the Owner Owner's Agent of the property located at

J. Dorian McKelvy

does hereby request permission to construct sanitary sewers and related facilities to serve a

Residential Non-residential Development at said location.

ENGINEER'S

LEA BRAZE Engineering

Name

2495 Industrial Pkwy West

Address

Hayward, CA 94545

CONTRACTOR'S

Name

Address

OWNER'S

Dorian McKelvy

Name

130 Shawnee Pass

Address

Portola Valley CA 94028

Applicant's Signature

Signed by [Signature]
Please Print Name

Address

130 Shawnee Pass, P.V., CA

Receipt of \$ 585 Application Fee is hereby acknowledged [Signature] 7/30/2021

Date

Receipt of \$ 2,000 Cash Deposit or Performance Bond

Comments SINGLE FAMILY HOME SEWER CONNECTION

Approved by the District Board on _____

Application approved and permit issued:

WEST BAY SANITARY DISTRICT

Sergio Ramirez, General Manager

Date _____

By _____

Final Acceptance by the District Board on _____

(SEE PERMIT CONDITIONS ON REVERSE)



WEST BAY SANITARY DISTRICT
EXHIBIT "B"
SITE LOCATION
130 SHAWNEE PASS
PORTOLA VALLEY, CA
GRINDER SYSTEM

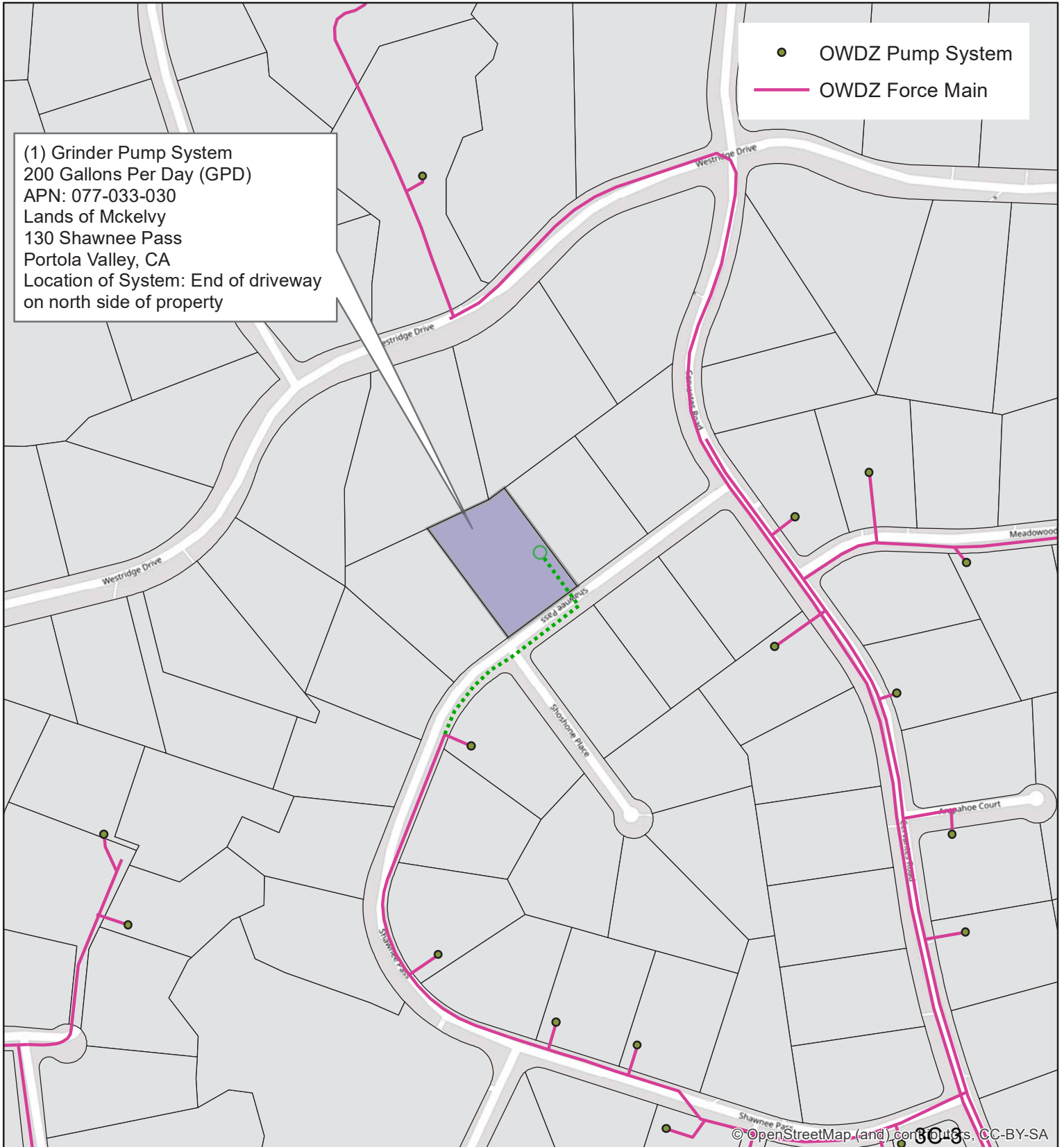

THIS PAGE LEFT INTENTIONALLY BLANK



**WEST BAY SANITARY DISTRICT
AGENDA ITEM 3D**

To: Board of Directors

From: Todd Reese, Office & Communications Manager

Subject: Consider Resolution Accepting Deed of Easement Pursuant to Class 3 Sewer Permit No. 1037 for the Construction of Wastewater Facilities for 3899 Alpine Road, Portola Valley, California

Background

The District requires an easement to maintain the flow from the STEP system that serves 3899 Alpine Road. The easement includes ingress and egress to the location of the STEP system and is conforming to District specifications.

Recommendation

The Office & Communications Manager recommends that the Board adopt the attached Resolution accepting the Deed of Easement.

Attachments: Resolution ____ (2023), Grant Deed of Easement

RESOLUTION NO. _____ (2023)

IN THE DISTRICT BOARD OF THE WEST BAY SANITARY DISTRICT

COUNTY OF SAN MATEO, STATE OF CALIFORNIA

BE IT RESOLVED that the President and Secretary of the West Bay Sanitary District be and are hereby authorized to accept the attached Grant Deed of Easement by and between the following parties:

Van Shadow Stables, LLC

BE IT FURTHER RESOLVED that the General Manager is hereby directed to place the same on record.

Passed and adopted by the District Board of the West Bay Sanitary District at a regular meeting thereof held on the 25th day of January, 2023, by the following vote:

Ayes:

Noes:

Abstain:

Absent:

President of the District Board of the West
Bay Sanitary District of San Mateo County,
State of California

Attest:

Secretary of the District Board of the
West Bay Sanitary District of San Mateo
County, State of California

RECORDING REQUESTED BY:
WEST BAY SANITARY DISTRICT

WHEN RECORDED MAIL TO:
WEST BAY SANITARY DISTRICT
500 LAUREL STREET
MENLO PARK, CA 94025

Title Order No. N/A
Escrow No. N/A
Parcel No.

GRANT DEED OF EASEMENT

THE UNDERSIGNED GRANTOR(S) DECLARE(S):

DOCUMENTARY TRANSFER TAX is \$0 CITY TAX is \$0 DEED TO PUBLIC AGENCY

computed on the full value of the property conveyed, or

computed on full value less value of liens or encumbrances remaining at the time of sale,

this is a conveyance of an easement and the consideration and value is less than \$100, R & T 11911 & R&T 11922.

Unincorporated area of Santa Clara County City/Town of _____

FOR NO CONSIDERATION, receipt of which is hereby acknowledged, I (we)

Van Shadow Stables, LLC

Hereby GRANT(S) to:

West Bay Sanitary District, a Public Agency organized and existing under the laws of the State of California,

A perpetual easement to construct, install, maintain, use, repair, remove, replace any and all pipeline, fittings, and related facilities necessary for the operation of a wastewater conveyance system in the area described as follows over the following described real property in the County of Santa Clara, State of California; more particularly described in Exhibit "A" and "B", attached hereto, and by this reference incorporated herein.

West Bay Sanitary District, its employees and agents shall have the right to enter upon the herein described real property at any and all times with such tools and equipment as may be necessary or convenient for the exercise of the rights herein granted to West Bay Sanitary District.

No building or structure of any kind shall be constructed upon the herein described easement, and should a building or structure be erected in violation of this provision, West Bay and its successors and assigns may still exercise all rights herein granted and shall have the right to remove, or cause grantor to remove, at Grantors expense, any building or structure that may be erected upon or over the said parcel of real property. West Bay Sanitary District shall not be held liable in any manner whatsoever for any damages thereby incurred, nor shall West Bay have any obligation to replace any structure that may be removed from said property.

This grant of easement shall be binding upon and shall inure to the benefit of the respective administrators, executors, personal representatives, successors and assigns of the parties hereto.

LEGAL DESCRIPTION ATTACHED HERETO AS EXHIBITS "A" AND "B" MADE A PART HEREOF

Also Known As: *3899 ALPINE ROAD*

Assessor's Parcel Number: *182-34-011*

Executed on *11.11*, *2022*, at *Menlo Park, CA*
(City and State)

Steven Baugher
Printed Name

[Signature]
Signature

Executed on _____, _____, at _____
(City and State)

Printed Name

Signature(s)

CALIFORNIA ACKNOWLEDGMENT

CIVIL CODE § 1189

A notary public or other officer completing this certificate verifies only the identity of the individual who signed the document to which this certificate is attached, and not the truthfulness, accuracy, or validity of that document.

State of California }
County of SAN MATEO }

On 11/11/2022 before me, STEVEN BAUGHER
Date Here Insert Name and Title of the Officer

personally appeared JUSTINE SINK
Name(s) of Signer(s)

who proved to me on the basis of satisfactory evidence to be the person(s) whose name(s) is/are subscribed to the within instrument and acknowledged to me that he/she/they executed the same in his/her/their authorized capacity(ies), and that by his/her/their signature(s) on the instrument the person(s), or the entity upon behalf of which the person(s) acted, executed the instrument.

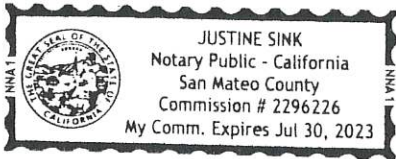

I certify under PENALTY OF PERJURY under the laws of the State of California that the foregoing paragraph is true and correct.

WITNESS my hand and official seal.

Signature [Handwritten Signature]
Signature of Notary Public

Place Notary Seal and/or Stamp Above

OPTIONAL

Completing this information can deter alteration of the document or fraudulent reattachment of this form to an unintended document.

Description of Attached Document

Title or Type of Document: GRANT DEED OF EASEMENT

Document Date: 11/11/22 Number of Pages: 1

Signer(s) Other Than Named Above:

Capacity(ies) Claimed by Signer(s)

Signer's Name: STEVEN BAUGHER

Signer's Name:

- Corporate Officer - Title(s):
Partner - Limited General
Individual Attorney in Fact
Trustee Guardian or Conservator
Other:

- Corporate Officer - Title(s):
Partner - Limited General
Individual Attorney in Fact
Trustee Guardian or Conservator
Other:

Signer is Representing:

Signer is Representing:

EXHIBIT "A"
LEGAL DESCRIPTION FOR
WEST BAY SANITARY DISTRICT
ACCESS EASEMENT

APN: 182-34-011

UNINCORPORATED SANTA CLARA COUNTY

An easement over that certain real property, situate in the Unincorporated Area of Santa Clara County, State of California, being a portion of the Lands of Van Shadow Stables, LLC as described in that certain Grant Deed recorded December 17, 2013 as Document No. 22473459, Santa Clara County Records, as shown on Exhibit "B" made a part hereof, more particularly described as follows:

Commencing at the most Northeastern corner of that certain Record of Survey filed May 14, 1968 in Book 237 of Maps at Page 31, Santa Clara County Records;
Thence along the Northeast line of said Record of Survey, North 57°41'14" West 235.87 feet to the most Southern corner of that certain Deed of Right of Way for Road Purposes, recorded October 15, 2015 as Document No. 23116974, Santa Clara County Records;
Thence leaving last said line along the East line of last deed, northerly along a non-tangent curve to the left to which a radial bears South 76° 33'46" East with a radius of 355.00 feet, through a central angle of 08°52'28", an arc length of 54.98 feet to the **Point of Beginning**;

Thence continuing along last East line the following two (2) courses:

- 1.) Along the continuation of last said curve to the left, through a central angle of 01°56'17", an arc length of 12.01 feet
- 2.) North 02°37'30" East 13.03 feet;

Thence leaving last said East line along the following six (6) courses:

- 1.) South 83°45'11" East 49.81 feet
- 2.) South 06°14'49" West 60.00 feet
- 3.) North 83°45'11" West 25.00 feet
- 4.) North 06°14'49" East 22.48 feet
- 5.) North 39°09'45" West 17.84 feet
- 6.) North 83°45'11" West 10.73 feet to the **Point of Beginning**.

Containing 1,181 square feet, more or less.

The bearings described are based on the Northeast line of said Record of Survey, described as North 57°41'14" West in said Document No. 23116974.

END OF DESCRIPTION



DEED OF
RIGHT OF WAY
DOC. 23116974

N02°37'30"E
13.03'

R=355.00'
L=12.01'
Δ=1°56'17"

POINT OF
BEGINNING

N83°45'11"W
10.73'

R=355.00'
L=54.98'
Δ=8°52'28"

S76°33'46"E
(RADIAL)

N57°41'14"W
235.87'

N39°09'45"W
17.84'

N83°45'11"W
25.00'

S83°45'11"E 49.81'

S06°14'49"W 60.00'

N06°14'49"E
22.48'



LANDS OF VAN SHADOW
STABLES LLC
DOC. 22473459
APN: 182-34-011

WEST BAY
SANITARY DISTRICT
ACCESS EASEMENT
1,181 SQ.FT.±

THE BEARINGS SHOWN ARE BASED
THE NORTHEAST LINE OF
RECORD OF SURVEY,
BOOK 237 PAGE 31, SANTA CLARA
COUNTY RECORDS, DESCRIBED AS
N57°41'14"W IN DOCUMENT NO.
23116974, SANTA CLARA COUNTY
RECORDS.

237 MAPS 31

POINT OF
COMMENCEMENT

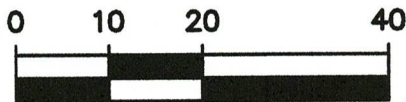

SCALE: 1" = 20'



LEA & BRAZE ENGINEERING, INC.

CIVIL ENGINEERS • LAND SURVEYORS

BAY AREA REGION
2495 INDUSTRIAL PKWY WEST
HAYWARD, CALIFORNIA 94545
(P) (510) 887-4086
(F) (510) 887-3019

SACRAMENTO REGION
3017 DOUGLAS BLVD, # 300
ROSEVILLE, CA 95661
(P) (916) 966-1338
(F) (916) 797-7363

WWW.LEABRAZE.COM

EXHIBIT "B"
**WEST BAY SANITARY DISTRICT
ACCESS EASEMENT**
UNICORPORTATED SANTA CLARA COUNTY

JOB NO 2100373

SCALE: 1" = 20'

CLOSURE CALCULATION

JN: 2100373

End North: 5361.7045' East: 7993.6329'

Segment #1 : Curve

Length: 12.01' Radius: 355.00'

Delta: 1°56'17" Tangent: 6.00'

Chord: 12.01' Course: N03° 35' 38"E

Course In: N85° 26' 14"W Course Out: S87°
22' 30"E

RP North: 5389.9452' East: 7639.7580'

End North: 5373.6909' East: 7994.3858'

Segment #2 : Line

Course: N02° 37' 30"E Length: 13.03'

North: 5386.7072' East: 7994.9825'

Segment #3 : Line

Course: S83° 45' 11"E Length: 49.81'

North: 5381.2872' East: 8044.4968'

Segment #4 : Line

Course: S06° 14' 49"W Length: 60.00'

North: 5321.6434' East: 8037.9679'

Segment #5 : Line

Course: N83° 45' 11"W Length: 25.00'

North: 5324.3638' East: 8013.1164'

Segment #6 : Line

Course: N06° 14' 49"E Length: 22.48'

North: 5346.7103' East: 8015.5625'

Segment #7 : Line

Course: N39° 09' 45"W Length: 17.84'

North: 5360.5427' East: 8004.2962'

Segment #8 : Line

Course: N83° 45' 11"W Length: 10.73'

North: 5361.7103' East: 7993.6299'

Perimeter: 210.89' Area: 2180.84 Sq. Ft.

Error Closure: 0.0065 Course: N27° 51'
52"W

Error North: 0.00578 East: -0.00306

Precision 1: 32446.15

THIS PAGE LEFT INTENTIONALLY BLANK



**WEST BAY SANITARY DISTRICT
AGENDA ITEM 3E**

To: Board of Directors

From: Todd Reese, Office & Communications Manager

Subject: Consider Accepting Sewer Facilities Constructed Pursuant to Class 3 Sewer Permit No. 1037 for the Construction of Wastewater Facilities for 3899 Alpine Road, Portola Valley, California

Background

This permit request was for the construction of a STEP system and to connect into an existing force main to serve 3899 Alpine Road, Portola Valley.

Analysis

The Board issued this Permit at the Regular Meeting of November, 2015.

The work has been completed and has been inspected, tested, and approved by staff as being in conformance with District standards. The property owner has submitted a one-year guarantee for the work in the form of a maintenance bond.

Recommendation

The Office & Communications Manager recommends that the Board accepts these facilities and directs the General Manager to approve the Class 3 Permit No. 1037.

Attachments: Class 3 Permit No. 1037
Exhibit A: Site map

WEST BAY SANITARY DISTRICT

500 Laurel Street
Menlo Park, California 94025
(650) 321-0384

Permit Number
No 1037

Type _____

APPLICATION FOR CLASS 3 SEWER PERMIT

To the WEST BAY SANITARY DISTRICT:

APN: 182-34-011

The undersigned, being the Owner Owner's Agent of the property located at

0 Arastradero Road, Portola Valley, CA

does hereby request permission to construct sanitary sewers and related facilities to serve a

Unincorporated Santa Clara Co.

Residential Non-residential Development at said location.

ENGINEER'S

Lea & Braze Engineering

Name

2495 Industrial Parkway W
Address Hayward, CA 94545

CONTRACTOR'S

Steve Baugher - Ranchworks LLC

Name

1760 The Alameda, Suite 300
Address

OWNER'S

Van Shadow LLC, c/o Steve Baugher

Name

1760 The Alameda Suite 300
Address San Jose, CA

Cooper Allison
Applicant's Signature

COOPER ALLISON - Lea & Braze
Signed by - Please Print Name

2495 Industrial Parkway W
Address

Receipt of \$ 500.00 Application Fee is hereby acknowledged 8/25/2015

Date

Receipt of \$ 2,000.00 Cash deposit or Performance Bond

Comments: Install a STEP/Grinder system to serve for hookup.

Approved by the District Board on _____

Application approved and permit issued:

WEST BAY SANITARY DISTRICT

Sergio Ramirez, General Manager

Date _____

By _____

Final Acceptance by the District Board on _____

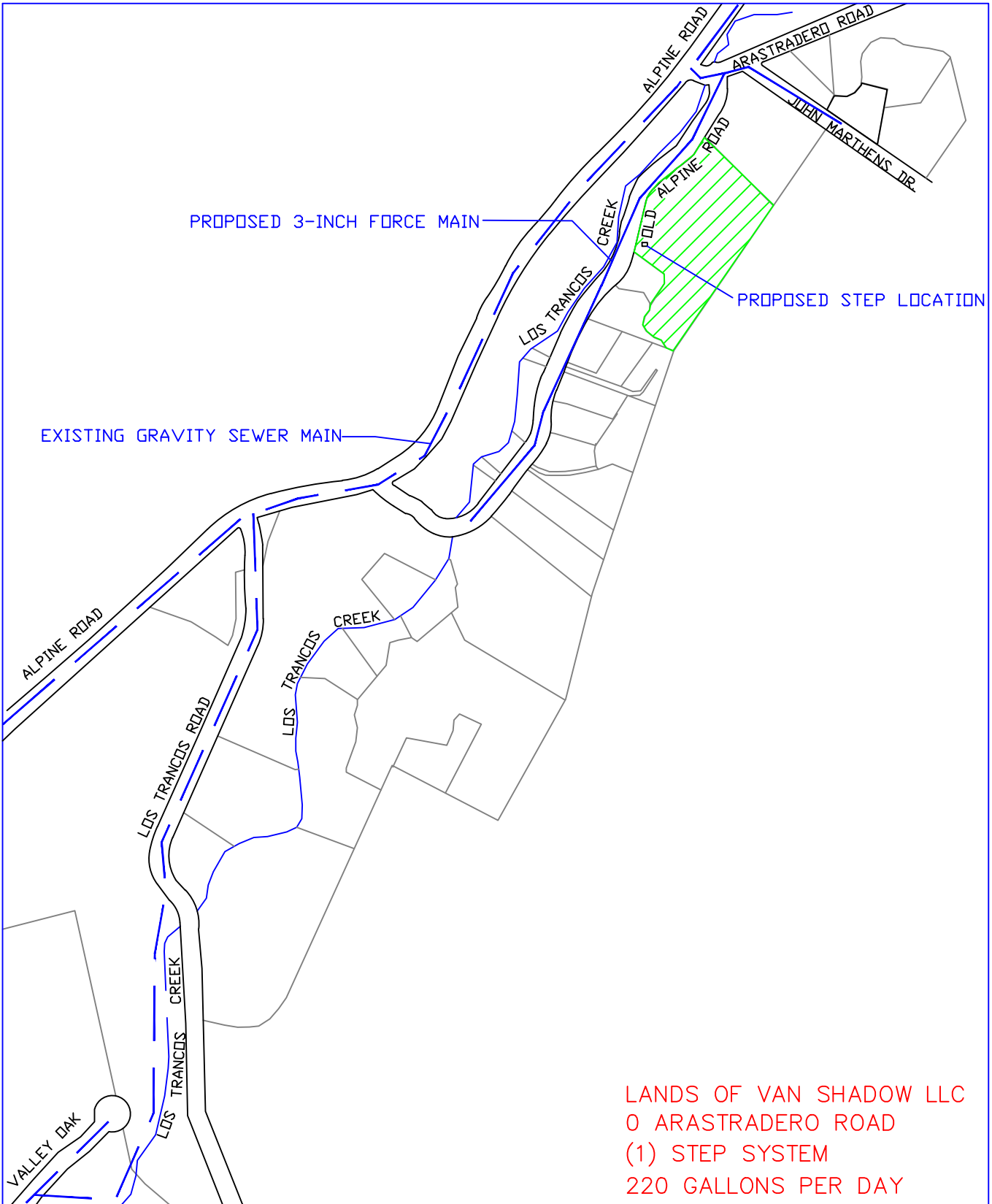

LANDS OF VAN SHADOW LLC
 0 ARASTRADERO ROAD
 (1) STEP SYSTEM
 220 GALLONS PER DAY

WEST BAY SANITARY DISTRICT

LANDS OF VAN SHADOW LLC

SITE MAP

WBSD1

THIS PAGE LEFT INTENTIONALLY BLANK



To: Board of Directors
From: Sergio Ramirez, General Manager
Subject: General Manager's Report

1) Administrative:

- a. Staff requested data on the Menlo Park Pump Station for the time period during the Ivy Drive Sanitary Sewer Overflow.
- b. The 2023 Master Plan consultant will commence shortly after the agreement is executed.

2) Finance:

- a. The Finance Manager is gathering data on the 5 year cash flow projections which will be reported to the Finance Committee in the coming weeks.
- b. All reserves are near or at the target levels. A 2nd Quarter report will be given to the Board at the January 25, 2023 meeting.
- c. A progress payment will be made for the North Ringwood Project for the Ravenswood Ave and Laurel St. pipe replacement and for substitute work on Sonoma Ave in Menlo Park where a pipeline was replaced in lieu of other pipeline work off of Van Buren Ave. The pipeline was not replaced because of access but will be addressed in the 2023 Master Plan.

3) CIP Projects:

a. Construction Capital Improvement Program (CIP):

- i. The Bayfront Park Sewer Improvements Project was awarded to Ranger Pipelines Inc. Construction should begin in the next 30 days or so, weather permitting.
- ii. The final work in the North Ringwood Project is to replace two pipeline segments in an easement at Albern Street and Menalto Avenue in East Palo Alto. The project was approved by the Board at the September 14th Regular Board Meeting.

b. Levee Improvement Project:

- i. The Bay Conservation and Development Commission has agreed to give the District "conditions of approval" so that we may finalize the Levee Design and move to the bid process.
- ii. The District is expecting to receive permits from the United States Army Corps of Engineers' (USACE) soon so the project can go to bid by February or March 2023.

4) Information Technology (IT):

- a. Staff will begin migrating to Microsoft Office 365 in early 2023.

Report to the District Board for the Regular Meeting of January 25, 2023

Additional information or topics may be introduced by the GM verbally during the Board meeting.

- 5) **Operations and Maintenance:**
 - a. **Collection System:**
 - i. The Town of Woodside will be purchasing its own bypass equipment, so we may continue to assist in responding to storm events to minimize a Sanitary Sewer Overflows (SSOs).
 - b. **Pump Facilities:**
 - i. During the January 25th Board Meeting, the Pump Supervisor and Superintendent will present on the ISAC System, which uses telephone lines and dial-up modems to communicate alarms but will no longer be supported.
 - c. **Training:**
 - i. Staff will receive training on the updated COVID-19 Response Plan.
- 6) **Water Quality:**
 - a. **Sharon Heights Golf and Country Club (SHGCC):**
 - i. The West Bay/SHGCC facility produced 5.4 million gallons for the month of December, however, only 154,690 gallons were received by the Club. The plant is at minimal levels of production.
 - b. **Bayfront Recycled Water Facility (BRWF):**
 - i. An agreement was sent to Meta regarding the Project Management.
 - c. **Woodside Recycled Water Facility (BRWF):**
 - i. The Woodside Recycled Water Facility feasibility is underway. Pass through invoices are being payed to Woodard and Curran but reimbursed by Menlo Country Club as part of the feasibility agreement.
- 7) **Fleet and Facilities:**
 - a. **Vehicle Maintenance:**
 - i. The District new half inch hydro jetter has been outfitted with traffic control lights, a radio, and a purple pipe fill inlet so it may use recycled water.
- 8) **Personnel:**
 - i. The recruitment for the Project Manager position was successful. The new Project Manager will be introduced at the January 25th Board Meeting.
 - ii. The Associate Engineering position will go out for recruitment once again.
- 9) **Upcoming Events:**
 - a. **Next Regular Board Meetings:** Wednesdays, February 8th and February 22nd.
- 10) **Misc. Items:**
 - a. **West Bay:** The District experienced 3 sanitary sewer overflow (SSO) in 2022.
 - b. **Town of Los Altos Hills:** Crews continue to clean and video inspect the Town's system.
 - c. **Town of Woodside:** Crews cleaned the entire system for the Town at the end of the year.

Report to the District Board for the Regular Meeting of January 25, 2023

Additional information or topics may be introduced by the GM verbally during the Board meeting.



**WEST BAY SANITARY DISTRICT
AGENDA ITEM 5**

To: Board of Directors

From: Sergio Ramirez, General Manager

**Subject: Presentation & Discussion on the Pump Station Integrated
Systems and Control (ISAC)**

District staff will give a presentation on the pump station Integrated Systems and Control (ISAC) and discuss the options available.

THIS PAGE LEFT INTENTIONALLY BLANK



WEST BAY SANITARY DISTRICT AGENDA ITEM 6

To: *Board of Directors*

From: *Debra Fisher, Finance Manager*

Subject: *Consider Approving District Treasury Report
Second Quarter FY 2022-23*

Background

In October 2010 the District named Bank of the West as the District's Investment advisor and approved an investment of \$5 million in available funds to establish the Emergency Capital Reserve. Subsequently, the Board has established several additional reserves to provide financial stability for the District.

Excess funds over the current monthly expenditures are held in the Local Agency Investment Fund (LAIF), which are equivalent to cash and may earn yields without a long term commitment. Operating Reserves, customer deposits, current capital projects, and Solid Waste Funds are held in LAIF

Restricted funds for Sharon Heights Golf & Country Club (SHGCC), as required for the Clean Water State Revolving Fund (SRF) loan are held in a Money Market account, as requested by SHGCC representatives.

There are currently five separate investment reserves maintained to support the goals of the District, along with reserves held in LAIF, the Vehicle & Equipment Reserve held in a money market account, a Pension Trust, and the restricted Recycled Water SRF Reserve. Annual contributions are made in accordance with the Board approved budget in order to reach the target balances for each reserve. On December 2, 2022, the Finance Committee reviewed the District investments and account balances and recommended transferring an additional \$10 million, over budgeted contributions to the investment reserve accounts, to achieve higher yields on current funds. The full Board reviewed the proposal and approved on December 14, 2022.

<u>Reserve Account</u>	<u>Originated</u>	<u>Target Balance</u>	<u>Target</u>
Operating Reserve	11/26/2014	\$11 million *	Achieved
Rate Stabilization Reserve	10/30/2015	\$10 million	Achieved
Treatment Plant Reserve	9/24/2021	\$12 million	Achieved
Capital Project Reserve	11/26/2014	\$6 million	Achieved
Emergency Capital Reserve	10/19/2010	\$5 million	Achieved
Recycled Water Cash Flow	11/18/2016	\$8 million	Achieved
Recycled Water SRF Reserve	3/01/2018	\$1.46 million	Achieved
Vehicle & Equipment Reserve	8/18/2011	\$1 million	Achieved

* Based on approved FY 2022-23 Budget, 6 months Operations \$11,111,437 (held in LAIF)

Fiscal Impact

The District had \$82,974,365 in cash and investments, including \$2,152,362 in restricted accounts, as of December 31, 2022.

The District allocated an additional \$361,837 of LAIF funds for the Operating Reserve, as approved in the FY 2022-23 budget, to meet six months of expenditures. Total transfers of \$3.6 million, approved in the FY 2022-23 Budget, have yet to be completed. The \$10 million transfers were made to achieve the target balance in all reserves on December 20, 2022.

The District had total funds of approximately \$26.7 million above the total \$54 million target reserve balances, combining all District unrestricted accounts, as of December 31, 2022. All reserve accounts have achieved the individual targets approved by the board.

The investment portfolios have been set up with the goal to yield a rate of return of approximately 2%. Current District yields in the Investment Reserves average 2.01%. LAIF’s yield was 2.173% in December 2022.

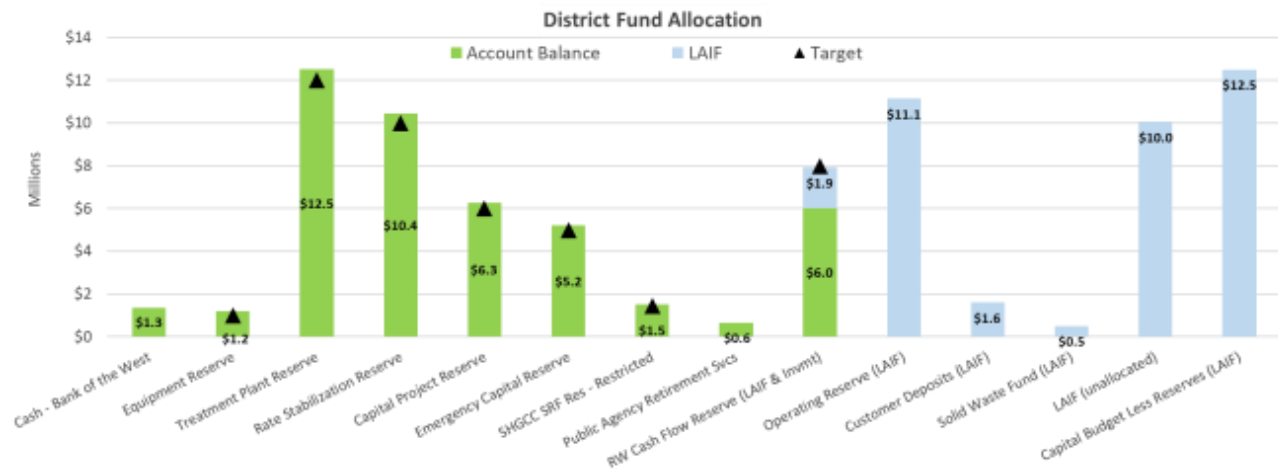

Recommendation

The Finance Manager recommends the District Board approve the report on the District’s Treasury Report, including investment portfolio statements detailing assets held, transactions, and changes in market value to the Reserve accounts described therein, for the second quarter fiscal year 2022-23.

Attachment: Schedule of Cash and Investments, December 31, 2022
Investment Statements 2nd Qtr FY2022-23

**West Bay Sanitary District
Schedule of Cash and Investments
Fiscal Year 2022-23
December 31, 2022**

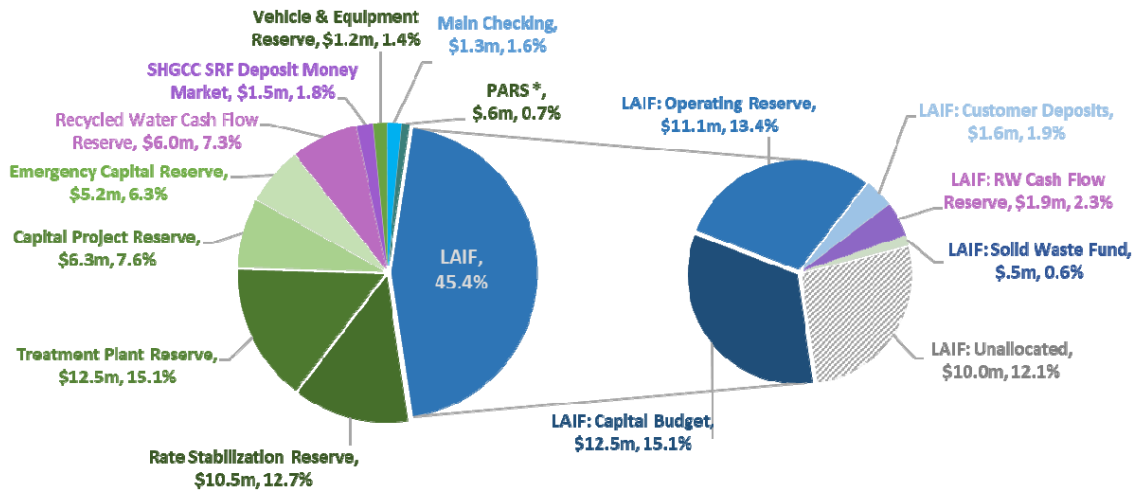

Description	Target	Cash & Equivalents	Fixed Income	Accrued Interest	Quarterly Yield
Bank of the West, Commercial Account		1,349,240.42			0.00%
NAVIA Commuter Checking Account		2,128.30			0.00%
Petty Cash		800.00			
Bank of the West Money Market Account		1,190,302.15			0.18%
Local Agency Investment Fund (LAIF)		37,668,163.91		0.00	2.17%
Cash & Equivalent Accounts		40,210,634.78		0.00	
Bank of the West Reserves Accounts					
Bank of The West - Rate Stabilization Reserve	\$10 million	57,214.00	10,388,607.92	50,510.32	2.17%
Bank of The West - Treatment Plant Reserve	\$12 million	101,277.14	12,403,418.20	43,149.74	2.03%
Bank of The West -Capital Project Reserve	\$6 million	38,288.51	6,230,901.75	25,587.02	1.82%
Bank of The West -Emergency Capital Reserve - Securities	\$5 million	33,495.16	5,189,107.11	23,466.37	2.02%
Bank of The West - Recycled Water Cash Flow Reserve - Securities	\$8 million	29,012.51	5,987,565.40	27,577.99	2.02%
Bank of the West Reserve Accounts		259,287	40,199,600	170,291	
Total Cash and Investments		40,469,922	40,199,600	170,291	
Restricted					
PARS Irrevocable Trust - Retirement			208,921		4.80%
PARS Irrevocable Trust - OPEB			408,815		4.80%
Total PARS Irrevocable Trust			617,736		
Bank of The West - Recycled Water SRF Money Market		1,516,815			0.11%
Restricted - Bank of the West Reserve Account		1,516,815			
Cash and Investments		\$ 41,986,737	\$ 40,817,336	\$ 170,291	
Total Cash and Investments		\$ 82,974,365			

Certification:

The General Manager/Chief Fiscal Officer and Finance Manager of West Bay Sanitary District represents that the above investments are in accordance with the West Bay Sanitary District Investment Policy, adopted by the District Board on September 14, 2022.

General Manager 1/19/2023
Date

Finance Manager 1/18/23
Date

Report to the District Board for the Regular Meeting of January 25, 2023



WBSD - RATE STABILIZATION RESERVE

Account Number:
 Statement Period:

61-J252-01-7
 10/01/22 - 12/31/22

WEST BAY SANITARY DISTRICT
 500 LAUREL STREET
 MENLO PARK CA 94025

Fiduciary
 Chuen Ying Lee
 (408) 645-3234
Portfolio
 Michael D. Smith
 (408) 490-2079

Asset Allocation

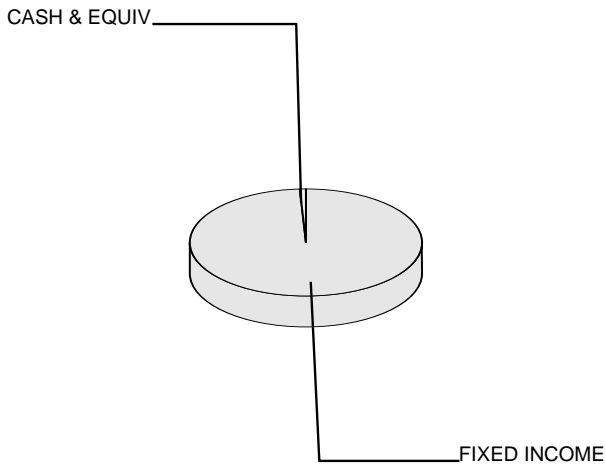

Asset Valuation

Description	Market Value	% of Account
Cash & Equiv	57,214.00	0.6%
Fixed Income	10,388,607.92	99.5%
Total Portfolio	\$ 10,445,821.92	100.0%
Accrued Income	50,510.32	
Total Valuation	\$ 10,496,332.24	

Market Reconciliation

	Current Period	Year To Date
Beginning Market Value	\$ 9,656,271.15	\$ 9,737,901.10
Income		
Interest.....	59,972.87	114,939.85
Purchased Income.....	-7,506.50	-8,028.78
Additions.....	767,700.00	767,700.00
Disbursements.....	-4,153.59	-8,359.48
Realized Gains/(Losses).....	0.00	-60.87
Change In Accrued Income.....	1,021.93	-1,364.19
Change In Market Appreciation/(Depreciation).....	43,329.40	-56,963.14
Non-Cash Asset Changes.....	-20,303.02	-49,432.25
Ending Market Value	\$ 10,496,332.24	\$ 10,496,332.24



WBSD - RATE STABILIZATION RESERVE

Account Number:
Statement Period:

61-J252-01-7
10/01/22 - 12/31/22

Asset Position As of 12/31/22

Asset Description	Units	Market Value Cost	Est. Annual Income Accruals	Current Yield
Cash Equivalents				
Bank of The West Advantage Acct	57,214.000	57,214.00 57,214.00	2,374.00 447.85	4.15%
Total Cash Equivalents		\$ 57,214.00 \$ 57,214.00	2,374.00 447.85	4.15%
Fixed Income				
Anz National Intl LTD Fr 3.40% Dtd 03/19/2019 Due 03/19/2024 Non-Callable	210,000.000	205,497.60 218,144.30	7,140.00 2,022.99	3.47%
American Express Co Sr Gbl 2.50% Dtd 07/30/2019 Due 07/30/2024 Callable	100,000.000	96,171.00 102,842.00	2,500.00 1,048.61	2.60%
American Tower Corp New Sr Gbl 3.50% Dtd 01/08/2013 Due 01/31/2023 Callable	100,000.000	99,880.00 101,486.00	3,500.00 1,468.05	3.50%
Apple Inc Sr Gbl Nt 0.75% Dtd 05/11/2020 Due 05/11/2023 Callable	40,000.000	39,423.60 40,081.20	300.00 41.66	0.76%
Apple Inc Sr Gbl 0.70% Dtd 02/08/2021 Due 02/08/2026 Callable	50,000.000	44,379.00 49,948.00	350.00 139.02	0.79%
Asotin Cnty Wash Taxable GO LTD Tax Bds 2021 B Taxable 0.407% Dtd 02/25/2021 Due 12/01/2023 Non-Callable	100,000.000	96,333.00 100,000.00	407.00 33.91	0.42%
BB&T Corp Sr Medium Term Nts Fr 3.70% Dtd 06/05/2018 Due 06/05/2025 Callable	25,000.000	24,306.00 26,762.50	925.00 66.80	3.81%
Bellevue Neb Ctfs Partn Taxable Ref Ctfs Partn Taxable 0.455% Dtd 03/15/2021 Due 09/15/2024 Non-Callable	150,000.000	143,352.00 150,000.00	682.00 200.95	0.48%
Blackrock Inc Sr Nt 3.50% Dtd 03/18/2014 Due 03/18/2024 Callable	210,000.000	206,568.60 219,389.60	7,350.00 2,102.91	3.56%



WBSD - RATE STABILIZATION RESERVE

Account Number:
Statement Period:

61-J252-01-7
10/01/22 - 12/31/22

Asset Position As of 12/31/22

Asset Description	Units	Market Value Cost	Est. Annual Income Accruals	Current Yield
Butte Silver Bow Mont City & C GO Bds 3.00% Dtd 12/28/2016 Due 07/01/2023 Non-Callable	50,000.000	50,018.50 51,259.50	1,500.00 750.00	3.00%
Carolina Beach NC Enterprise S Rev Bds 4.00% Dtd 06/30/2016 Due 06/01/2023 Non-Callable	75,000.000	75,306.00 76,362.25	3,000.00 249.99	3.98%
Chambers Cnty Tex Comb Tax and Rev Cfs Ob 5.00% Dtd 08/01/2015 Due 03/01/2023 Non-Callable	65,000.000	65,202.80 66,524.90	3,250.00 1,083.33	4.98%
Charlotte N C Cfs Partn Taxable Cops 2015a Taxable 2.965% Dtd 05/14/2015 Due 06/01/2023 Callable	155,000.000	153,899.50 156,990.20	4,595.00 382.97	2.99%
Colorado Hsg & Fin Auth Taxable Single Family MT 2020 C Taxable 1.928% Dtd 02/20/2020 Due 11/01/2023 Non-Callable	250,000.000	243,100.00 253,580.00	4,820.00 803.33	1.98%
Colorado St Brd Governors Univ Rev Ref Bds 2012b 5.00% Dtd 05/01/2012 Due 03/01/2023 Non-Callable	200,000.000	200,628.00 204,072.00	10,000.00 3,333.33	4.98%
Comcast Corp New Sr Nt 3.375% Dtd 05/27/2015 Due 08/15/2025 Callable	60,000.000	57,873.00 64,496.40	2,025.00 765.00	3.50%
Deere John Capital Corp Fr 3.45% Dtd 03/13/2018 Due 03/13/2025 Non-Callable	110,000.000	107,069.60 117,011.60	3,795.00 1,138.50	3.54%
Federal Home Loan Bks Cons Bds 0.60% Dtd 04/30/2021 Due 10/30/2024 Callable	250,000.000	231,602.50 250,000.00	1,500.00 254.16	0.65%
Federal Farm Cr Bks Cons Systemwide Bds 0.30% Dtd 01/13/2021 Due 01/13/2025 Callable	200,000.000	182,994.00 199,700.00	600.00 280.00	0.33%
Grant Cnty Wash Pub Util Dist Taxable Sys Ref Bds 2020 Q Taxable 1.877% Dtd 01/29/2020 Due 01/01/2023 Callable	75,000.000	75,000.00 75,571.50	1,407.00 703.87	1.88%
Hamilton Cnty Ohio Sales Tax Sales Tax Bds 2000 B Zero Cpn Dtd 11/09/2000 Due 12/01/2023 Non-Callable	65,000.000	63,117.60 64,750.39	0.00	0.00%



WBSD - RATE STABILIZATION RESERVE

Account Number:
Statement Period:

61-J252-01-7
10/01/22 - 12/31/22

Asset Position As of 12/31/22

Asset Description	Units	Market Value Cost	Est. Annual Income Accruals	Current Yield
Kla Tencor Corp Sr Gbl Nt 4.65% Dtd 11/06/2014 Due 11/01/2024 Callable	150,000.000	149,545.50 160,411.50	6,975.00 1,162.50	4.66%
Laboratory Corp Amer Hldgs Sr Nt 4.00% Dtd 11/01/2013 Due 11/01/2023 Callable	111,000.000	110,168.61 114,428.79	4,440.00 739.99	4.03%
League City Tex Combi Tax and Rev Cfs O 5.00% Dtd 07/01/2017 Due 02/15/2023 Non-Callable	140,000.000	140,298.20 142,608.20	7,000.00 2,644.44	4.99%
Long Is Pwr Auth N Y Elec Sys Gen Bds 2020 A 5.00% Dtd 08/20/2020 Due 09/01/2023 Non-Callable	45,000.000	45,573.30 47,053.35	2,250.00 750.00	4.94%
Maine Mun Bd Bk Liquor Operati Rev Bds Taxable 4.252% Dtd 09/05/2013 Due 06/01/2023 Callable	100,000.000	99,746.00 101,825.00	4,252.00 354.33	4.26%
Nedrose Pub Sch Dist No 4 N D Taxable GO Bldg Ref Bds Taxable 0.35% Dtd 02/17/2021 Due 08/01/2024 Non-Callable	100,000.000	93,402.00 100,041.00	350.00 145.83	0.37%
New York Life Gbl Fdg MTN 144a Sr Sec Gbl 1.10% Dtd 05/07/2020 Due 05/05/2023 Non-Callable	110,000.000	108,663.50 110,399.30	1,210.00 188.22	1.11%
Newark Calif Uni Sch Dist Bds 2002 D Zero Cpn Dtd 04/30/2002 Due 08/01/2023 Non-Callable	75,000.000	73,659.75 74,842.28	0.00	0.00%
Ohio St Common Schs GO Ref Bds 2016 A 5.00% Dtd 03/09/2016 Due 12/15/2023 Non-Callable	45,000.000	45,922.50 46,630.35	2,250.00 100.00	4.90%
Pajaro Valley Calif Uni Sch Di GO Bds 2005 B Zero Cpn Dtd 05/19/2005 Due 08/01/2023 Non-Callable	50,000.000	49,051.00 49,883.27	0.00	0.00%
Paypal Hldgs Inc Sr Gbl 2.40% Dtd 09/26/2019 Due 10/01/2024 Callable	73,000.000	69,961.01 75,275.41	1,752.00 438.00	2.50%
San Francisco Calif Bay Area R Taxable Ref Bds 2019 B Taxable 1.971% Dtd 10/31/2019 Due 07/01/2024 Non-Callable	100,000.000	96,084.00 102,723.00	1,971.00 985.50	2.05%



WBSD - RATE STABILIZATION RESERVE

Account Number:
Statement Period:

61-J252-01-7
10/01/22 - 12/31/22

Asset Position As of 12/31/22

Asset Description	Units	Market Value Cost	Est. Annual Income Accruals	Current Yield
South Dakota Hsg Dev Auth Taxable Homeownership MT 2021 C Taxable 0.671% Dtd 08/04/2021 Due 05/01/2024 Non-Callable	200,000.000	188,220.00 200,000.00	1,342.00 223.66	0.71%
State Str Corp Sr Sb Nt 3.10% Dtd 05/15/2013 Due 05/15/2023 Non-Callable	200,000.000	198,664.00 202,610.90	6,200.00 792.22	3.12%
Tennessee Valley Auth Sr Glbl A Bd 0.75% Dtd 05/11/2020 Due 05/15/2025 Non-Callable	190,000.000	173,631.50 191,356.70	1,425.00 182.08	0.82%
Global Pmts Inc Sr Glbl Nt 4.00% Dtd 05/11/2018 Due 06/01/2023 Callable	75,000.000	74,547.00 76,255.50	3,000.00 249.99	4.02%
Toyota Motor Credit Corp Fr 2.90% Dtd 04/01/2020 Due 03/30/2023 Non-Callable	10,000.000	9,960.30 10,096.20	290.00 73.30	2.91%
Toyota Motor Credit Corp Fr 3.00% Dtd 04/01/2020 Due 04/01/2025 Callable	300,000.000	288,075.00 316,091.50	9,000.00 2,250.00	3.12%
US Treasury Note 0.125% Dtd 09/15/2020 Due 09/15/2023	150,000.000	145,300.50 144,310.55	187.00 55.93	0.13%
US Treasury Note 0.125% Dtd 12/15/2020 Due 12/15/2023	120,000.000	114,957.60 116,370.47	150.00 7.00	0.13%
US Treasury Note 0.50% Dtd 02/28/2021 Due 02/28/2026	40,000.000	35,648.80 35,804.69	200.00 67.95	0.56%
US Treasury Note 0.75% Dtd 03/31/2021 Due 03/31/2026	240,000.000	215,138.40 238,687.50	1,800.00 459.88	0.84%
US Treasury Note 0.375% Dtd 04/15/2021 Due 04/15/2024	100,000.000	94,641.00 95,980.87	375.00 80.35	0.40%
US Treasury Note 0.375% Dtd 08/15/2021 Due 08/15/2024	80,000.000	74,750.40 75,289.41	300.00 113.31	0.40%
US Treasury Note 1.00% Dtd 12/15/2021 Due 12/15/2024	200,000.000	187,220.00 191,615.82	2,000.00 93.40	1.07%
US Treasury Note 0.75% Dtd 12/31/2021 Due 12/31/2023	100,000.000	96,131.00 97,684.60	750.00 2.07	0.78%
US Treasury Note 0.875% Dtd 01/31/2022 Due 01/31/2024	90,000.000	86,396.40 87,816.48	787.00 329.55	0.91%



WBSD - RATE STABILIZATION RESERVE

Account Number:
Statement Period:

61-J252-01-7
10/01/22 - 12/31/22

Asset Position As of 12/31/22

Asset Description	Units	Market Value Cost	Est. Annual Income Accruals	Current Yield
US Treasury Note 1.625% Dtd 02/15/2016 Due 02/15/2026	200,000.000	185,032.00 190,871.76	3,250.00 1,227.58	1.76%
US Treasury Note 1.625% Dtd 10/31/2016 Due 10/31/2023	700,000.000	682,668.00 700,685.15	11,375.00 1,948.20	1.67%
US Treasury Note 2.50% Dtd 05/15/2014 Due 05/15/2024	80,000.000	77,668.80 79,621.87	2,000.00 259.66	2.58%
US Treasury Note 2.00% Dtd 06/30/2017 Due 06/30/2024	120,000.000	115,440.00 118,086.38	2,400.00 6.62	2.08%
US Treasury Note 2.75% Dtd 06/30/2018 Due 06/30/2025	200,000.000	192,720.00 191,233.09	5,500.00 15.19	2.85%
US Treasury Note 1.625% Dtd 10/31/2019 Due 10/31/2026	200,000.000	182,602.00 183,875.00	3,250.00 556.63	1.78%
US Treasury Note 1.75% Dtd 12/31/2019 Due 12/31/2026	150,000.000	137,362.50 138,378.75	2,625.00 7.25	1.91%
US Treasury Note 1.875% Dtd 07/31/2019 Due 07/31/2026	200,000.000	185,000.00 186,265.62	3,750.00 1,569.29	2.03%
US Treasury Note 2.625% Dtd 02/28/2018 Due 02/28/2023	600,000.000	598,272.00 604,291.55	15,750.00 5,351.51	2.63%
US Treasury Note 2.625% Dtd 06/30/2018 Due 06/30/2023	650,000.000	643,799.00 654,060.75	17,062.00 47.13	2.65%
US Treasury Note 2.50% Dtd 01/31/2019 Due 01/31/2024	200,000.000	195,360.00 199,508.82	5,000.00 2,092.39	2.56%
US Treasury Note 2.375% Dtd 02/28/2019 Due 02/29/2024	550,000.000	535,799.00 556,309.16	13,062.00 4,438.36	2.44%
US Treasury Note 2.375% Dtd 04/30/2019 Due 04/30/2026	260,000.000	245,661.00 247,132.03	6,175.00 1,057.60	2.51%
US Treasury Note 1.75% Dtd 06/30/2019 Due 06/30/2024	220,000.000	210,856.80 210,264.09	3,850.00 10.63	1.83%
University Calif Revs Gen Rev Bds 2015 A Taxable 2.909% Dtd 03/25/2015 Due 05/15/2023 Callable	160,000.000	159,067.20 161,387.40	4,654.00 594.72	2.93%
Waco Tex Indpt Sch Dist Taxable Unltd Tax Ref Bd Taxable Zero Cpn Dtd 01/01/2021 Due 08/15/2024 Non-Callable	300,000.000	276,975.00 297,346.80	0.00	0.00%



WBSD - RATE STABILIZATION RESERVE

Account Number:
 Statement Period:

61-J252-01-7
 10/01/22 - 12/31/22

Asset Position As of 12/31/22

Asset Description	Units	Market Value Cost	Est. Annual Income Accruals	Current Yield
Waco Tex Indpt Sch Dist Taxable Unltd Tax Ref Bd Taxable Zero Cpn Dtd 01/01/2021 Due 08/15/2025 Non-Callable	150,000.000	131,644.50 147,184.40	0.00	0.00%
West Hollywood Calif Pub Fing Rev Bds 5.00% Dtd 06/30/2016 Due 04/01/2023 Non-Callable	55,000.000	55,264.55 56,263.05	2,750.00 687.50	4.98%
William S Hart Calif Un High S GO Bds 2013 C 4.00% Dtd 02/21/2013 Due 08/01/2023 Non-Callable	50,000.000	50,336.00 51,795.00	2,000.00 833.33	3.97%
Total Fixed Income		\$ 10,388,607.92 \$ 10,769,625.65	224,355.00 50,062.47	2.16%
Cash				
Principal Cash		0.00 0.00	0.00	0.00%
Income Cash		0.00 0.00	0.00	0.00%
Total Cash		\$ 0.00 \$ 0.00	0.00 0.00	0.00%
Total Market Value		\$ 10,445,821.92 \$ 10,826,839.65	226,729.00 50,510.32	2.17%
Total Market Value Plus Accruals		\$ 10,496,332.24		

Income Activity

	Date	Income Cash	Principal Cash
Interest Income			
Bank of The West Advantage Acct			
Int To 09/30/22	10/03/22		239.85
Int To 10/31/22	11/01/22		926.92
Int To 11/30/22	12/01/22		387.28
Apple Inc Sr Gbl Nt 0.75% Dtd 05/11/2020 Due 05/11/2023 Callable			
Int To 11/11/22 on 40,000	11/11/22		150.00



WBSD - RATE STABILIZATION RESERVE

Account Number:
 Statement Period:

61-J252-01-7
 10/01/22 - 12/31/22

Income Activity			
	Date	Income Cash	Principal Cash
Asotin Cnty Wash Taxable GO LTD Tax Bds 2021 B Taxable 0.407% Dtd 02/25/2021 Due 12/01/2023 Non-Callable Int To 12/01/22 on 100,000	12/01/22		203.50
BB&T Corp Sr Medium Term Nts Fr 3.70% Dtd 06/05/2018 Due 06/05/2025 Callable Int To 12/05/22 on 25,000	12/05/22		462.50
Carolina Beach NC Enterprise S Rev Bds 4.00% Dtd 06/30/2016 Due 06/01/2023 Non-Callable Int To 12/01/22 on 75,000	12/01/22		1,500.00
Charlotte N C Ctfs Partn Taxable Cops 2015a Taxable 2.965% Dtd 05/14/2015 Due 06/01/2023 Callable Int To 12/01/22 on 155,000	12/01/22		2,297.87
Colorado Hsg & Fin Auth Taxable Single Family MT 2020 C Taxable 1.928% Dtd 02/20/2020 Due 11/01/2023 Non-Callable Int To 11/01/22 on 250,000	11/01/22		2,410.00
Federal Home Loan Bks Cons Bds 0.60% Dtd 04/30/2021 Due 10/30/2024 Callable Int To 10/30/22 on 250,000	10/31/22		750.00
Kla Tencor Corp Sr Gbl Nt 4.65% Dtd 11/06/2014 Due 11/01/2024 Callable Int To 11/01/22 on 150,000	11/01/22		3,487.50
Laboratory Corp Amer Hldgs Sr Nt 4.00% Dtd 11/01/2013 Due 11/01/2023 Callable Int To 11/01/22 on 111,000	11/01/22		2,220.00
Maine Mun Bd Bk Liquor Operati Rev Bds Taxable 4.252% Dtd 09/05/2013 Due 06/01/2023 Callable Int To 12/01/22 on 100,000	12/01/22		2,126.00
New York Life Gbl Fdg MTN 144a Sr Sec Gbl 1.10% Dtd 05/07/2020 Due 05/05/2023 Non-Callable Int To 11/05/22 on 110,000	11/07/22		605.00



WBSD - RATE STABILIZATION RESERVE

Account Number:
Statement Period:

61-J252-01-7
10/01/22 - 12/31/22

Income Activity			
	Date	Income Cash	Principal Cash
Ohio St Common Schs GO Ref Bds 2016 A 5.00% Dtd 03/09/2016 Due 12/15/2023 Non-Callable Int To 12/15/22 on 45,000	12/15/22		1,125.00
Paypal Hldgs Inc Sr Gbl 2.40% Dtd 09/26/2019 Due 10/01/2024 Callable Int To 10/01/22 on 73,000	10/03/22		876.00
South Dakota Hsg Dev Auth Taxable Homeownership MT 2021 C Taxable 0.671% Dtd 08/04/2021 Due 05/01/2024 Non-Callable Int To 11/01/22 on 200,000	11/01/22		671.00
State Str Corp Sr Sb Nt 3.10% Dtd 05/15/2013 Due 05/15/2023 Non-Callable Int To 11/15/22 on 200,000	11/15/22		3,100.00
Tennessee Valley Auth Sr Gbl A Bd 0.75% Dtd 05/11/2020 Due 05/15/2025 Non-Callable Int To 11/15/22 on 190,000	11/15/22		712.50
Global Pmts Inc Sr Gbl Nt 4.00% Dtd 05/11/2018 Due 06/01/2023 Callable Int To 12/01/22 on 75,000	12/01/22		1,500.00
Toyota Motor Credit Corp Fr 3.00% Dtd 04/01/2020 Due 04/01/2025 Callable Int To 10/01/22 on 300,000	10/03/22		4,500.00
US Treasury Bill Due 10/06/2022 Interest on Maturity of 400,000	10/06/22		1,976.00
US Treasury Note 0.125% Dtd 12/15/2020 Due 12/15/2023 Int To 12/15/22 on 120,000	12/15/22		75.00
US Treasury Note 0.375% Dtd 04/15/2021 Due 04/15/2024 Int To 10/15/22 on 100,000	10/17/22		187.50
US Treasury Note 1.00% Dtd 12/15/2021 Due 12/15/2024 Int To 12/15/22 on 200,000	12/15/22		1,000.00



WBSD - RATE STABILIZATION RESERVE

Account Number:
Statement Period:

61-J252-01-7
10/01/22 - 12/31/22

Income Activity			
	Date	Income Cash	Principal Cash
US Treasury Note 0.75% Dtd 12/31/2021 Due 12/31/2023 Int To 12/31/22 on 100,000	12/30/22		375.00
US Treasury Note 1.625% Dtd 10/31/2016 Due 10/31/2023 Int To 10/31/22 on 700,000	10/31/22		5,687.50
US Treasury Note 2.50% Dtd 05/15/2014 Due 05/15/2024 Int To 11/15/22 on 80,000	11/15/22		1,000.00
US Treasury Note 2.00% Dtd 06/30/2017 Due 06/30/2024 Int To 12/31/22 on 120,000	12/30/22		1,200.00
US Treasury Note 2.75% Dtd 06/30/2018 Due 06/30/2025 Int To 12/31/22 on 200,000	12/30/22		2,750.00
US Treasury Note 1.75% Dtd 12/31/2019 Due 12/31/2026 Int To 12/31/22 on 150,000	12/30/22		1,312.50
US Treasury Note 2.625% Dtd 06/30/2018 Due 06/30/2023 Int To 12/31/22 on 650,000	12/30/22		8,531.25
US Treasury Note 1.75% Dtd 06/30/2019 Due 06/30/2024 Int To 12/31/22 on 220,000	12/30/22		1,925.00
University Calif Revs Gen Rev Bds 2015 A Taxable 2.909% Dtd 03/25/2015 Due 05/15/2023 Callable Int To 11/15/22 on 160,000	11/15/22		2,327.20
West Hollywood Calif Pub Fing Rev Bds 5.00% Dtd 06/30/2016 Due 04/01/2023 Non-Callable Int To 10/01/22 on 55,000	10/03/22		1,375.00
Total Interest Income		\$ 0.00	\$ 59,972.87
Purchased Income			
US Treasury Note 0.50% Dtd 02/28/2021 Due 02/28/2026 Accrued Int To 12/27/22 Paid on Purchase of 40,000	12/27/22		-65.19



WBSD - RATE STABILIZATION RESERVE

Account Number:
 Statement Period:

61-J252-01-7
 10/01/22 - 12/31/22

Income Activity			
	Date	Income Cash	Principal Cash
US Treasury Note 2.75% Dtd 06/30/2018 Due 06/30/2025 Accrued Int To 11/08/22 Paid on Purchase of 200,000	11/08/22		-1,957.88
US Treasury Note 1.625% Dtd 10/31/2019 Due 10/31/2026 Accrued Int To 12/23/22 Paid on Purchase of 200,000	12/23/22		-475.83
US Treasury Note 1.75% Dtd 12/31/2019 Due 12/31/2026 Accrued Int To 12/23/22 Paid on Purchase of 150,000	12/23/22		-1,255.43
US Treasury Note 1.875% Dtd 07/31/2019 Due 07/31/2026 Accrued Int To 12/23/22 Paid on Purchase of 200,000	12/23/22		-1,477.58
US Treasury Note 2.375% Dtd 04/30/2019 Due 04/30/2026 Accrued Int To 12/23/22 Paid on Purchase of 260,000	12/23/22		-904.08
US Treasury Note 1.75% Dtd 06/30/2019 Due 06/30/2024 Accrued Int To 11/08/22 Paid on Purchase of 220,000	11/08/22		-1,370.51
Total Purchased Income		\$ 0.00	\$ -7,506.50
Total Income		\$ 0.00	\$ 52,466.37

Additions			
	Date	Income Cash	Principal Cash
Miscellaneous Additions			
Addition To Account ACH Transfer From Botw Ckg Ending In 6049 Per Client Instructions: 12/15/22	12/20/22		767,700.00
Total Miscellaneous Additions		\$ 0.00	\$ 767,700.00
Total Additions		\$ 0.00	\$ 767,700.00



WBSD - RATE STABILIZATION RESERVE

Account Number:
 Statement Period:

61-J252-01-7
 10/01/22 - 12/31/22

Disbursement Activity			
	Date	Income Cash	Principal Cash
Fees/Expenses			
Monthly Fee To 09/30/22	10/14/22		-1,383.12
Monthly Fee To 10/31/22	11/15/22		-1,382.53
Monthly Fee To 11/30/22	12/15/22		-1,387.94
Total Fees/Expenses		\$ 0.00	\$ -4,153.59
Total Disbursements		\$ 0.00	\$ -4,153.59

Purchase Activity			
	Date	Income Cash	Principal Cash
Bank of The West Advantage Acct Purchases (13) 10/01/22 To 12/31/22	12/31/22		-1,225,696.87
US Treasury Note 0.50% Dtd 02/28/2021 Due 02/28/2026 Purchased 40000 12/23/22 From Wells Fargo Securities, LLC @ 89.511718	12/27/22		-35,804.69
US Treasury Note 2.75% Dtd 06/30/2018 Due 06/30/2025 Purchased 200000 11/07/22 From Wells Fargo Securities, LLC @ 95.363281	11/08/22		-190,726.56
US Treasury Note 1.625% Dtd 10/31/2019 Due 10/31/2026 Purchased 200000 12/22/22 From Wells Fargo Securities, LLC @ 91.9375	12/23/22		-183,875.00
US Treasury Note 1.75% Dtd 12/31/2019 Due 12/31/2026 Purchased 150000 12/22/22 From BNY Mellon/Toronto Dominion Sec @ 92.214843	12/23/22		-138,322.26
US Treasury Note 1.875% Dtd 07/31/2019 Due 07/31/2026 Purchased 200000 12/22/22 From Morgan Stanley & Co @ 93.132812	12/23/22		-186,265.62



WBSD - RATE STABILIZATION RESERVE

Account Number:
 Statement Period:

61-J252-01-7
 10/01/22 - 12/31/22

Purchase Activity			
	Date	Income Cash	Principal Cash
US Treasury Note 2.375% Dtd 04/30/2019 Due 04/30/2026 Purchased 260000 12/22/22 From Wells Fargo Securities, LLC @ 95.050781	12/23/22		-247,132.03
US Treasury Note 1.75% Dtd 06/30/2019 Due 06/30/2024 Purchased 220000 11/07/22 From Wells Fargo Securities, LLC @ 95.148437	11/08/22		-209,326.56
Total Purchases		\$ 0.00	\$ -2,417,149.59

Sale Activity			
	Date	Proceeds	Realized Gain/Loss
Bank of The West Advantage Acct Sales (6) 10/01/22 To 12/31/22	12/31/22	1,203,112.81	
US Treasury Bill Due 10/06/2022 Recd Proceeds on Maturity of 400,000 Par Value	10/06/22	398,024.00	
Total Sales		\$ 1,601,136.81	\$ 0.00

Non-Cash Activity		
	Date	Cost
Apple Inc Sr Gbl Nt 0.75% Dtd 05/11/2020 Due 05/11/2023 Callable Amortization of Premium	11/11/22	-40.40
Amortization of Premium	11/11/22	-40.80
BB&T Corp Sr Medium Term Nts Fr 3.70% Dtd 06/05/2018 Due 06/05/2025 Callable Amortization of Premium	12/05/22	-348.00
Carolina Beach NC Enterprise S Rev Bds 4.00% Dtd 06/30/2016 Due 06/01/2023 Non-Callable Amortization of Premium	12/01/22	-896.50
Amortization of Premium	12/01/22	-464.00



WBSD - RATE STABILIZATION RESERVE

Account Number:
 Statement Period:

61-J252-01-7
 10/01/22 - 12/31/22

Non-Cash Activity

	Date	Cost
Charlotte N C Ctfs Partn Taxable Cops 2015a Taxable 2.965% Dtd 05/14/2015 Due 06/01/2023 Callable Amortization of Premium	12/01/22	-1,988.65
Colorado Hsg & Fin Auth Taxable Single Family MT 2020 C Taxable 1.928% Dtd 02/20/2020 Due 11/01/2023 Non-Callable Amortization of Premium	11/01/22	-1,785.00
Hamilton Cnty Ohio Sales Tax Sales Tax Bds 2000 B Zero Cpn Dtd 11/09/2000 Due 12/01/2023 Non-Callable Accretion of Discount	10/31/22	22.60
Accretion of Discount	11/30/22	22.60
Accretion of Discount	12/30/22	22.60
Kla Tencor Corp Sr Gbl Nt 4.65% Dtd 11/06/2014 Due 11/01/2024 Callable Amortization of Premium	11/01/22	-2,566.50
Laboratory Corp Amer Hldgs Sr Nt 4.00% Dtd 11/01/2013 Due 11/01/2023 Callable Amortization of Premium	11/01/22	-1,702.74
Maine Mun Bd Bk Liquor Operati Rev Bds Taxable 4.252% Dtd 09/05/2013 Due 06/01/2023 Callable Amortization of Premium	12/01/22	-1,820.00
New York Life Gbl Fdg MTN 144a Sr Sec Gbl 1.10% Dtd 05/07/2020 Due 05/05/2023 Non-Callable Amortization of Premium	11/04/22	-398.20
Newark Calif Uni Sch Dist Bds 2002 D Zero Cpn Dtd 04/30/2002 Due 08/01/2023 Non-Callable Accretion of Discount	10/31/22	22.39
Accretion of Discount	11/30/22	22.39
Accretion of Discount	12/30/22	22.39
Ohio St Common Schs GO Ref Bds 2016 A 5.00% Dtd 03/09/2016 Due 12/15/2023 Non-Callable Amortization of Premium	12/15/22	-807.30



WBSD - RATE STABILIZATION RESERVE

Account Number:
 Statement Period:

61-J252-01-7
 10/01/22 - 12/31/22

Non-Cash Activity

	Date	Cost
Pajaro Valley Calif Uni Sch Di GO Bds 2005 B Zero Cpn Dtd 05/19/2005 Due 08/01/2023 Non-Callable		
Accretion of Discount	10/31/22	16.57
Accretion of Discount	11/30/22	16.57
Accretion of Discount	12/30/22	16.57
Paypal Hldgs Inc Sr Gbl 2.40% Dtd 09/26/2019 Due 10/01/2024 Callable		
Amortization of Premium	10/03/22	-563.56
State Str Corp Sr Sb Nt 3.10% Dtd 05/15/2013 Due 05/15/2023 Non-Callable		
Amortization of Premium	11/15/22	-1,433.30
Amortization of Premium	11/15/22	-1,173.60
Tennessee Valley Auth Sr Gbl A Bd 0.75% Dtd 05/11/2020 Due 05/15/2025 Non-Callable		
Amortization of Premium	11/15/22	-259.50
Amortization of Premium	11/15/22	-10.80
Global Pmts Inc Sr Gbl Nt 4.00% Dtd 05/11/2018 Due 06/01/2023 Callable		
Amortization of Premium	12/01/22	-1,251.75
Toyota Motor Credit Corp Fr 3.00% Dtd 04/01/2020 Due 04/01/2025 Callable		
Amortization of Premium	10/03/22	-1,217.70
Amortization of Premium	10/03/22	-1,033.00
Amortization of Premium	10/03/22	-929.70
US Treasury Note 0.125% Dtd 12/15/2020 Due 12/15/2023		
Accretion of Discount	12/15/22	1,250.16
US Treasury Note 0.375% Dtd 04/15/2021 Due 04/15/2024		
Accretion of Discount	10/14/22	699.62
US Treasury Note 1.00% Dtd 12/15/2021 Due 12/15/2024		
Accretion of Discount	12/15/22	1,443.94
US Treasury Note 0.75% Dtd 12/31/2021 Due 12/31/2023		
Accretion of Discount	12/30/22	1,086.94



WBSD - RATE STABILIZATION RESERVE

Account Number:
Statement Period:

61-J252-01-7
10/01/22 - 12/31/22

Non-Cash Activity		
	Date	Cost
US Treasury Note 1.625% Dtd 10/31/2016 Due 10/31/2023 Amortization of Premium	10/31/22	-338.68
US Treasury Note 2.00% Dtd 06/30/2017 Due 06/30/2024 Accretion of Discount	12/30/22	598.88
US Treasury Note 2.75% Dtd 06/30/2018 Due 06/30/2025 Accretion of Discount	12/30/22	506.53
US Treasury Note 1.75% Dtd 12/31/2019 Due 12/31/2026 Accretion of Discount	12/30/22	56.49
US Treasury Note 2.625% Dtd 06/30/2018 Due 06/30/2023 Amortization of Premium	12/30/22	-4,033.17
US Treasury Note 1.75% Dtd 06/30/2019 Due 06/30/2024 Accretion of Discount	12/30/22	937.53
University Calif Revs Gen Rev Bds 2015 A Taxable 2.909% Dtd 03/25/2015 Due 05/15/2023 Callable Amortization of Premium	11/15/22	-1,071.90
Amortization of Premium	11/15/22	-308.00
Waco Tex Indpt Sch Dist Taxable Unltd Tax Ref Bd Taxable Zero Cpn Dtd 01/01/2021 Due 08/15/2024 Non-Callable Accretion of Discount	10/31/22	68.02
Accretion of Discount	10/31/22	68.02
Accretion of Discount	11/30/22	68.02
Accretion of Discount	11/30/22	68.02
Accretion of Discount	12/30/22	68.02
Accretion of Discount	12/30/22	68.02
Waco Tex Indpt Sch Dist Taxable Unltd Tax Ref Bd Taxable Zero Cpn Dtd 01/01/2021 Due 08/15/2025 Non-Callable Accretion of Discount	10/31/22	89.38
Accretion of Discount	11/30/22	89.38
Accretion of Discount	12/30/22	89.38



WBSD - RATE STABILIZATION RESERVE

Account Number:
Statement Period:

61-J252-01-7
10/01/22 - 12/31/22

Non-Cash Activity

	Date	Cost
West Hollywood Calif Pub Fing Rev Bds 5.00% Dtd 06/30/2016 Due 04/01/2023 Non-Callable Amortization of Premium	10/03/22	-114.80
Amortization of Premium	10/03/22	-1,146.50
Total Non-Cash Transactions		\$ -20,303.02

SECURITY PRICES CONTAINED IN THIS STATEMENT ARE OBTAINED FROM THE MOST RELIABLE SOURCES AVAILABLE BUT ARE NOT GUARANTEED BY BANK OF THE WEST. QUOTED PRICES MAY NOT EQUAL ACTUAL PRICES BECAUSE OF SECURITY SIZE, MARKET PRICE, TERM AND DEMAND.



Electronic Funds Transfers

Preauthorized Transfers:

You may request an electronic fund transfer (EFT), such as an ACH transfer from or deposit to your account, by contacting your account Administrator. You may also preauthorize periodic EFTs by contacting your account Administrator. If you would like to know whether a preauthorized EFT has occurred, please contact your account Administrator at the phone number listed on the first page of your statement. TTY 1-866-936-2689, Monday - Friday, 8 a.m. - 4:30 p.m. Central Time.

Error Resolution Notice:

If you think a statement or receipt is wrong or if you need more information about an EFT listed on a statement or receipt, telephone your account Administrator at the phone number listed on the first page of your statement, TTY 1-866-936-2689, Monday - Friday, 8 a.m. - 4:30 p.m. Central Time, write to us at Bank of the West, GIFS Operations, 12000 North Washington Street, Suite, 300, Thornton, CO 80241 or e-mail us at WMGGIFSOperations@bankofthewest.com as soon as possible. We must hear from you no later than 60 days after we sent the FIRST statement on which the problem or error appeared.

1. Tell us your name and account number (if any).
2. Tell us the dollar amount of the suspected error.
3. Describe the error or the transfer you are unsure about, and explain as clearly as you can why you believe it is an error or why you need more information.

If you contact us verbally, we may require that you send us your complaint or question in writing within 10 business days. We will investigate your complaint and will correct any error promptly. If we take more than 10 business days to do this, we will credit your account for the amount you think is in error, so that you will have the use of the money during the time it takes us to complete our investigation.



WBSD - TREATMENT PLANT RESERVE

Account Number: 61-J236-01-0
 Statement Period: 10/01/22 - 12/31/22

WEST BAY SANITARY DISTRICT
 500 LAUREL STREET
 MENLO PARK CA 94025

Fiduciary
 Chuen Ying Lee
 (408) 645-3234
Portfolio
 Michael D. Smith
 (408) 490-2079

Asset Allocation

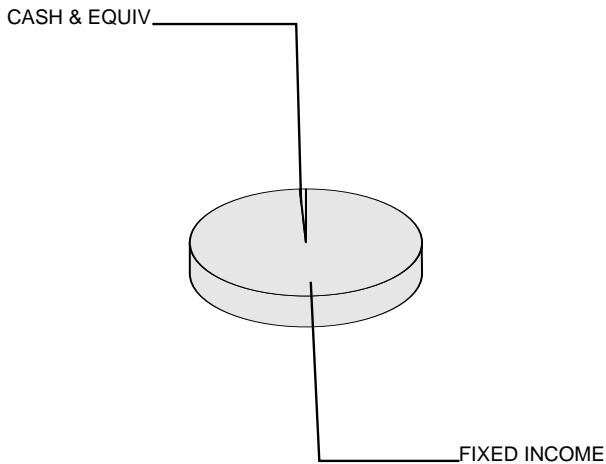

Asset Valuation

Description	Market Value	% of Account
Cash & Equiv	101,277.14	0.8%
Fixed Income	12,403,418.20	99.2%
Total Portfolio	\$ 12,504,695.34	100.0%
Accrued Income	43,149.74	
Total Valuation	\$ 12,547,845.08	

Market Reconciliation

	Current Period	Year To Date
Beginning Market Value	\$ 4,642,229.55	\$ 2,493,136.18
Income		
Interest.....	57,000.06	71,006.25
Purchased Income.....	-58,697.24	-61,420.21
Additions.....	7,916,100.00	10,118,211.08
Disbursements.....	-1,998.22	-3,706.69
Realized Gains/(Losses).....	0.00	0.00
Change In Accrued Income.....	26,653.48	32,960.02
Change In Market Appreciation/(Depreciation).....	-49,192.64	-121,692.69
Non-Cash Asset Changes.....	15,750.09	19,351.14
Ending Market Value	\$ 12,547,845.08	\$ 12,547,845.08



WBSD - TREATMENT PLANT RESERVE

Account Number:
Statement Period:

61-J236-01-0
10/01/22 - 12/31/22

Asset Position As of 12/31/22

Asset Description	Units	Market Value Cost	Est. Annual Income Accruals	Current Yield
Cash Equivalents				
Bank of The West Advantage Acct	101,277.140	101,277.14 101,277.14	4,203.00 2,710.37	4.15%
Total Cash Equivalents		\$ 101,277.14 \$ 101,277.14	4,203.00 2,710.37	4.15%
Fixed Income				
US Treasury Note 0.125% Dtd 09/15/2020 Due 09/15/2023	20,000.000	19,373.40 19,241.41	25.00 7.45	0.13%
US Treasury Note 0.125% Dtd 12/15/2020 Due 12/15/2023	40,000.000	38,319.20 38,790.16	50.00 2.33	0.13%
US Treasury Note 0.50% Dtd 02/28/2021 Due 02/28/2026	380,000.000	338,663.60 340,144.53	1,900.00 645.58	0.56%
US Treasury Note 0.375% Dtd 04/15/2021 Due 04/15/2024	500,000.000	473,205.00 479,904.37	1,875.00 401.78	0.40%
US Treasury Note 0.50% Dtd 11/30/2021 Due 11/30/2023	400,000.000	384,860.00 389,865.98	2,000.00 175.82	0.52%
US Treasury Note 1.00% Dtd 12/15/2021 Due 12/15/2024	40,000.000	37,444.00 38,323.16	400.00 18.68	1.07%
US Treasury Note 0.75% Dtd 12/31/2021 Due 12/31/2023	300,000.000	288,393.00 293,053.81	2,250.00 6.21	0.78%
US Treasury Note 0.875% Dtd 01/31/2022 Due 01/31/2024	1,150,000.000	1,103,954.00 1,118,657.21	10,062.00 4,210.93	0.91%
US Treasury Note 2.25% Dtd 03/31/2022 Due 03/31/2024	750,000.000	727,792.50 746,080.54	16,875.00 4,311.46	2.32%
US Treasury Note 2.00% Dtd 08/15/2015 Due 08/15/2025	1,000,000.000	944,500.00 948,164.06	20,000.00 7,554.35	2.12%
US Treasury Note 2.50% Dtd 05/15/2014 Due 05/15/2024	1,000,000.000	970,860.00 998,368.27	25,000.00 3,245.85	2.58%
US Treasury Note 2.00% Dtd 06/30/2017 Due 06/30/2024	600,000.000	577,200.00 590,431.94	12,000.00 33.14	2.08%
US Treasury Note 2.75% Dtd 06/30/2018 Due 06/30/2025	960,000.000	925,056.00 929,561.74	26,400.00 72.92	2.85%



WBSD - TREATMENT PLANT RESERVE

Account Number:
 Statement Period:

61-J236-01-0
 10/01/22 - 12/31/22

Asset Position As of 12/31/22

Asset Description	Units	Market Value Cost	Est. Annual Income Accruals	Current Yield
US Treasury Note 1.625% Dtd 10/31/2019 Due 10/31/2026	1,000,000.000	913,010.00 919,375.00	16,250.00 2,783.15	1.78%
US Treasury Note 1.75% Dtd 12/31/2019 Due 12/31/2026	1,000,000.000	915,750.00 922,525.04	17,500.00 48.34	1.91%
US Treasury Note 1.875% Dtd 07/31/2019 Due 07/31/2026	1,000,000.000	925,000.00 931,328.12	18,750.00 7,846.46	2.03%
US Treasury Note 3.00% Dtd 10/31/2018 Due 10/31/2025	1,000,000.000	965,940.00 971,367.18	30,000.00 5,138.12	3.11%
US Treasury Note 2.625% Dtd 12/31/2018 Due 12/31/2025	1,000,000.000	956,490.00 961,693.59	26,250.00 72.51	2.74%
US Treasury Note 2.375% Dtd 04/30/2019 Due 04/30/2026	950,000.000	897,607.50 902,982.42	22,562.00 3,864.29	2.51%
Total Fixed Income		\$ 12,403,418.20 \$ 12,539,858.53	250,149.00 40,439.37	2.02%
Cash				
Principal Cash		0.00 0.00	0.00	0.00%
Income Cash		0.00 0.00	0.00	0.00%
Total Cash		\$ 0.00 \$ 0.00	0.00 0.00	0.00%
Total Market Value		\$ 12,504,695.34 \$ 12,641,135.67	254,352.00 43,149.74	2.03%
Total Market Value Plus Accruals		\$ 12,547,845.08		

Income Activity

	Date	Income Cash	Principal Cash
Interest Income			
Bank of The West Advantage Acct			
Int To 09/30/22	10/03/22		38.67
Int To 10/31/22	11/01/22		37.26
Int To 11/30/22	12/01/22		61.63



WBSD - TREATMENT PLANT RESERVE

Account Number:
 Statement Period:

61-J236-01-0
 10/01/22 - 12/31/22

Income Activity			
	Date	Income Cash	Principal Cash
US Treasury Note 0.125% Dtd 12/15/2020 Due 12/15/2023 Int To 12/15/22 on 40,000	12/15/22		25.00
US Treasury Note 0.375% Dtd 04/15/2021 Due 04/15/2024 Int To 10/15/22 on 500,000	10/17/22		937.50
US Treasury Note 0.50% Dtd 11/30/2021 Due 11/30/2023 Int To 11/30/22 on 400,000	11/30/22		1,000.00
US Treasury Note 1.00% Dtd 12/15/2021 Due 12/15/2024 Int To 12/15/22 on 40,000	12/15/22		200.00
US Treasury Note 0.75% Dtd 12/31/2021 Due 12/31/2023 Int To 12/31/22 on 300,000	12/30/22		1,125.00
US Treasury Note 2.50% Dtd 05/15/2014 Due 05/15/2024 Int To 11/15/22 on 1,000,000	11/15/22		12,500.00
US Treasury Note 2.00% Dtd 06/30/2017 Due 06/30/2024 Int To 12/31/22 on 600,000	12/30/22		6,000.00
US Treasury Note 2.75% Dtd 06/30/2018 Due 06/30/2025 Int To 12/31/22 on 960,000	12/30/22		13,200.00
US Treasury Note 1.75% Dtd 12/31/2019 Due 12/31/2026 Int To 12/31/22 on 1,000,000	12/30/22		8,750.00
US Treasury Note 2.625% Dtd 12/31/2018 Due 12/31/2025 Int To 12/31/22 on 1,000,000	12/30/22		13,125.00
Total Interest Income		\$ 0.00	\$ 57,000.06
Purchased Income			
US Treasury Note 0.50% Dtd 02/28/2021 Due 02/28/2026 Accrued Int To 12/27/22 Paid on Purchase of 380,000	12/27/22		-619.34



WBSD - TREATMENT PLANT RESERVE

Account Number:
 Statement Period:

61-J236-01-0
 10/01/22 - 12/31/22

Income Activity			
	Date	Income Cash	Principal Cash
US Treasury Note 2.00% Dtd 08/15/2015 Due 08/15/2025 Accrued Int To 12/23/22 Paid on Purchase of 1,000,000	12/23/22		-7,065.22
US Treasury Note 2.75% Dtd 06/30/2018 Due 06/30/2025 Accrued Int To 12/23/22 Paid on Purchase of 960,000	12/23/22		-12,626.09
US Treasury Note 1.625% Dtd 10/31/2019 Due 10/31/2026 Accrued Int To 12/23/22 Paid on Purchase of 1,000,000	12/23/22		-2,379.15
US Treasury Note 1.75% Dtd 12/31/2019 Due 12/31/2026 Accrued Int To 12/23/22 Paid on Purchase of 1,000,000	12/23/22		-8,369.56
US Treasury Note 1.875% Dtd 07/31/2019 Due 07/31/2026 Accrued Int To 12/23/22 Paid on Purchase of 1,000,000	12/23/22		-7,387.91
US Treasury Note 3.00% Dtd 10/31/2018 Due 10/31/2025 Accrued Int To 12/23/22 Paid on Purchase of 1,000,000	12/23/22		-4,392.27
US Treasury Note 2.625% Dtd 12/31/2018 Due 12/31/2025 Accrued Int To 12/23/22 Paid on Purchase of 1,000,000	12/23/22		-12,554.35
US Treasury Note 2.375% Dtd 04/30/2019 Due 04/30/2026 Accrued Int To 12/23/22 Paid on Purchase of 950,000	12/23/22		-3,303.35
Total Purchased Income		\$ 0.00	\$ -58,697.24
Total Income		\$ 0.00	\$ -1,697.18



WBSD - TREATMENT PLANT RESERVE

Account Number:
 Statement Period:

61-J236-01-0
 10/01/22 - 12/31/22

Additions			
	Date	Income Cash	Principal Cash
Miscellaneous Additions			
Addition To Account ACH Transfer From Botw Ckg Ending In 6049 Per Client Instructions: 12/15/22	12/20/22		7,916,100.00
Total Miscellaneous Additions		\$ 0.00	\$ 7,916,100.00
Total Additions		\$ 0.00	\$ 7,916,100.00

Disbursement Activity			
	Date	Income Cash	Principal Cash
Fees/Expenses			
Monthly Fee To 09/30/22	10/14/22		-665.98
Monthly Fee To 10/31/22	11/15/22		-664.83
Monthly Fee To 11/30/22	12/15/22		-667.41
Total Fees/Expenses		\$ 0.00	\$ -1,998.22
Total Disbursements		\$ 0.00	\$ -1,998.22

Purchase Activity			
	Date	Income Cash	Principal Cash
Bank of The West Advantage Acct Purchases (9) 10/01/22 To 12/31/22	12/31/22		-7,973,100.06
US Treasury Note 0.50% Dtd 02/28/2021 Due 02/28/2026 Purchased 380000 12/23/22 From Wells Fargo Securities, LLC @ 89.511718	12/27/22		-340,144.53
US Treasury Note 2.00% Dtd 08/15/2015 Due 08/15/2025 Purchased 1000000 12/22/22 From Wells Fargo Securities, LLC @ 94.816406	12/23/22		-948,164.06



WBSD - TREATMENT PLANT RESERVE

Account Number:
 Statement Period:

61-J236-01-0
 10/01/22 - 12/31/22

Purchase Activity			
	Date	Income Cash	Principal Cash
US Treasury Note 2.75% Dtd 06/30/2018 Due 06/30/2025 Purchased 960000 12/22/22 From Wells Fargo Securities, LLC @ 96.804687	12/23/22		-929,325.00
US Treasury Note 1.625% Dtd 10/31/2019 Due 10/31/2026 Purchased 1000000 12/22/22 From Wells Fargo Securities, LLC @ 91.9375	12/23/22		-919,375.00
US Treasury Note 1.75% Dtd 12/31/2019 Due 12/31/2026 Purchased 1000000 12/22/22 From BNY Mellon/Toronto Dominion Sec @ 92.214843	12/23/22		-922,148.43
US Treasury Note 1.875% Dtd 07/31/2019 Due 07/31/2026 Purchased 1000000 12/22/22 From Morgan Stanley & Co @ 93.132812	12/23/22		-931,328.12
US Treasury Note 3.00% Dtd 10/31/2018 Due 10/31/2025 Purchased 1000000 12/22/22 From Wells Fargo Securities, LLC @ 97.136718	12/23/22		-971,367.18
US Treasury Note 2.625% Dtd 12/31/2018 Due 12/31/2025 Purchased 1000000 12/22/22 From Wells Fargo Securities, LLC @ 96.144531	12/23/22		-961,445.31
US Treasury Note 2.375% Dtd 04/30/2019 Due 04/30/2026 Purchased 950000 12/22/22 From Wells Fargo Securities, LLC @ 95.050781	12/23/22		-902,982.42
Total Purchases		\$ 0.00	\$ -15,799,380.11



WBSD - TREATMENT PLANT RESERVE

Account Number:
Statement Period:

61-J236-01-0
10/01/22 - 12/31/22

Sale Activity			
	Date	Proceeds	Realized Gain/Loss
Bank of The West Advantage Acct Sales (5) 10/01/22 To 12/31/22	12/31/22	7,886,975.51	
Total Sales		\$ 7,886,975.51	\$ 0.00

Non-Cash Activity		
	Date	Cost
US Treasury Note 0.125% Dtd 12/15/2020 Due 12/15/2023 Accretion of Discount	12/15/22	416.72
US Treasury Note 0.375% Dtd 04/15/2021 Due 04/15/2024 Accretion of Discount	10/14/22	3,498.12
US Treasury Note 0.50% Dtd 11/30/2021 Due 11/30/2023 Accretion of Discount	11/30/22	3,912.85
US Treasury Note 1.00% Dtd 12/15/2021 Due 12/15/2024 Accretion of Discount	12/15/22	288.78
US Treasury Note 0.75% Dtd 12/31/2021 Due 12/31/2023 Accretion of Discount	12/30/22	3,260.84
US Treasury Note 2.50% Dtd 05/15/2014 Due 05/15/2024 Accretion of Discount	11/15/22	516.71
US Treasury Note 2.00% Dtd 06/30/2017 Due 06/30/2024 Accretion of Discount	12/30/22	2,994.44
US Treasury Note 2.75% Dtd 06/30/2018 Due 06/30/2025 Accretion of Discount	12/30/22	236.74
US Treasury Note 1.75% Dtd 12/31/2019 Due 12/31/2026 Accretion of Discount	12/30/22	376.61
US Treasury Note 2.625% Dtd 12/31/2018 Due 12/31/2025 Accretion of Discount	12/30/22	248.28
Total Non-Cash Transactions		\$ 15,750.09



BANK OF THE WEST
BNP PARIBAS
WEALTH MANAGEMENT

WBSD - TREATMENT PLANT RESERVE

Account Number:
Statement Period:

61-J236-01-0
10/01/22 - 12/31/22

SECURITY PRICES CONTAINED IN THIS STATEMENT ARE OBTAINED FROM THE MOST RELIABLE SOURCES AVAILABLE BUT ARE NOT GUARANTEED BY BANK OF THE WEST. QUOTED PRICES MAY NOT EQUAL ACTUAL PRICES BECAUSE OF SECURITY SIZE, MARKET PRICE, TERM AND DEMAND.



Electronic Funds Transfers

Preauthorized Transfers:

You may request an electronic fund transfer (EFT), such as an ACH transfer from or deposit to your account, by contacting your account Administrator. You may also preauthorize periodic EFTs by contacting your account Administrator. If you would like to know whether a preauthorized EFT has occurred, please contact your account Administrator at the phone number listed on the first page of your statement. TTY 1-866-936-2689, Monday - Friday, 8 a.m. - 4:30 p.m. Central Time.

Error Resolution Notice:

If you think a statement or receipt is wrong or if you need more information about an EFT listed on a statement or receipt, telephone your account Administrator at the phone number listed on the first page of your statement, TTY 1-866-936-2689, Monday - Friday, 8 a.m. - 4:30 p.m. Central Time, write to us at Bank of the West, GIFS Operations, 12000 North Washington Street, Suite, 300, Thornton, CO 80241 or e-mail us at WMGGIFSOperations@bankofthewest.com as soon as possible. We must hear from you no later than 60 days after we sent the FIRST statement on which the problem or error appeared.

1. Tell us your name and account number (if any).
2. Tell us the dollar amount of the suspected error.
3. Describe the error or the transfer you are unsure about, and explain as clearly as you can why you believe it is an error or why you need more information.

If you contact us verbally, we may require that you send us your complaint or question in writing within 10 business days. We will investigate your complaint and will correct any error promptly. If we take more than 10 business days to do this, we will credit your account for the amount you think is in error, so that you will have the use of the money during the time it takes us to complete our investigation.



WBSD - CAPITAL PROJECT RESERVE

Account Number: 61-J235-01-2
Statement Period: 10/01/22 - 12/31/22

WEST BAY SANITARY DISTRICT
 500 LAUREL STREET
 MENLO PARK CA 94025

Fiduciary
 Chuen Ying Lee
 (408) 645-3234
Portfolio
 Michael D. Smith
 (408) 490-2079

Asset Allocation

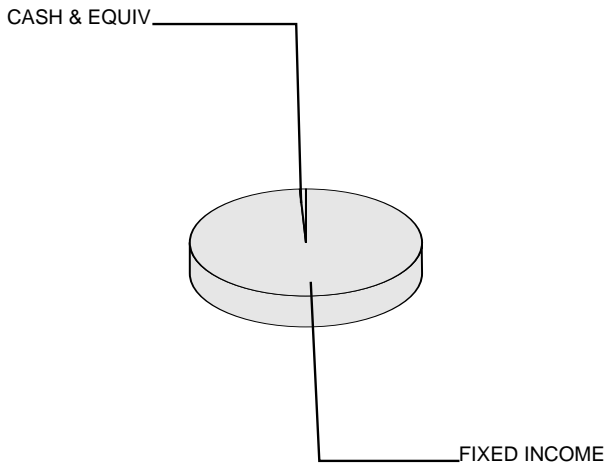

Asset Valuation

Description	Market Value	% of Account
Cash & Equiv	38,288.51	0.6%
Fixed Income	6,230,901.75	99.4%
Total Portfolio	\$ 6,269,190.26	100.0%
Accrued Income	25,587.02	
Total Valuation	\$ 6,294,777.28	

Market Reconciliation

	Current Period	Year To Date
Beginning Market Value	\$ 5,774,796.45	\$ 5,830,876.97
Income		
Interest.....	30,884.21	69,365.66
Purchased Income.....	-4,886.15	-5,361.90
Additions.....	479,000.00	479,000.00
Disbursements.....	-2,486.79	-5,005.36
Realized Gains/(Losses).....	0.00	0.00
Change In Accrued Income.....	741.91	-8,996.06
Change In Market Appreciation/(Depreciation).....	21,139.74	-42,975.16
Non-Cash Asset Changes.....	-4,412.09	-22,126.87
Ending Market Value	\$ 6,294,777.28	\$ 6,294,777.28



WBSD - CAPITAL PROJECT RESERVE

Account Number:
Statement Period:

61-J235-01-2
10/01/22 - 12/31/22

Asset Position As of 12/31/22

Asset Description	Units	Market Value Cost	Est. Annual Income Accruals	Current Yield
Cash Equivalents				
Bank of The West Advantage Acct	38,288.510	38,288.51 38,288.51	1,588.00 282.39	4.15%
Total Cash Equivalents		\$ 38,288.51 \$ 38,288.51	1,588.00 282.39	4.15%
Fixed Income				
Anz National Intl LTD Fr 3.40% Dtd 03/19/2019 Due 03/19/2024 Non-Callable	60,000.000	58,713.60 62,323.80	2,040.00 578.00	3.47%
American Express Co Sr Gbl Nt 3.00% Dtd 10/30/2017 Due 10/30/2024 Callable	90,000.000	87,031.80 93,865.50	2,700.00 457.50	3.10%
Apple Inc Sr Gbl Nt 0.75% Dtd 05/11/2020 Due 05/11/2023 Callable	10,000.000	9,855.90 10,020.20	75.00 10.41	0.76%
Apple Inc Sr Gbl 0.70% Dtd 02/08/2021 Due 02/08/2026 Callable	50,000.000	44,379.00 49,948.00	350.00 139.02	0.79%
Blackrock Inc Sr Nt 3.50% Dtd 03/18/2014 Due 03/18/2024 Callable	60,000.000	59,019.60 62,679.60	2,100.00 600.83	3.56%
California St GO Bds 5.00% Dtd 03/14/2017 Due 08/01/2023 Non-Callable	60,000.000	60,739.20 62,076.60	3,000.00 1,249.99	4.94%
Clackamas Cnty Ore Sch Dist No GO Bds B 5.00% Dtd 03/02/2017 Due 06/15/2023 Non-Callable	70,000.000	70,637.00 71,607.70	3,500.00 155.55	4.95%
Comcast Corp New Sr Nt 3.375% Dtd 05/27/2015 Due 08/15/2025 Callable	45,000.000	43,404.75 48,363.75	1,518.00 573.75	3.50%
Deere John Capital Corp Fr 3.45% Dtd 03/13/2018 Due 03/13/2025 Non-Callable	50,000.000	48,668.00 53,495.50	1,725.00 517.50	3.54%
Federal Home Loan Bks Cons Bds 0.60% Dtd 04/30/2021 Due 12/30/2024 Callable	50,000.000	46,055.00 50,000.00	300.00 50.83	0.65%



WBSD - CAPITAL PROJECT RESERVE

Account Number:
Statement Period:

61-J235-01-2
10/01/22 - 12/31/22

Asset Position As of 12/31/22

Asset Description	Units	Market Value Cost	Est. Annual Income Accruals	Current Yield
Federal Home Loan Bks Cons Bds 0.60% Dtd 04/30/2021 Due 10/30/2024 Callable	100,000.000	92,641.00 100,000.00	600.00 101.66	0.65%
Federal Farm Cr Bks Cons Systemwide Bds 0.71% Dtd 04/21/2021 Due 04/21/2025 Callable	300,000.000	272,634.00 300,000.00	2,130.00 414.16	0.78%
Federal Natl Mtg Assn Gtd Passthru CTF Pool #AN4889 2.750% Dtd 03/01/2017 Due 03/01/2024 IPD24	200,000.000	194,316.00 211,076.00	5,500.00 473.61	2.83%
Kla Tencor Corp Sr Gbl Nt 4.65% Dtd 11/06/2014 Due 11/01/2024 Callable	50,000.000	49,848.50 53,467.50	2,325.00 387.49	4.66%
LA Canada Calif Uni Sch Dist Taxable GO Ref Bds Taxable 1.65% Dtd 04/28/2020 Due 08/01/2023 Non-Callable	60,000.000	59,028.00 60,000.00	990.00 412.50	1.68%
League City Tex Combi Tax and Rev Ctfs O 5.00% Dtd 07/01/2017 Due 02/15/2023 Non-Callable	65,000.000	65,138.45 66,210.95	3,250.00 1,227.77	4.99%
Long Is Pwr Auth N Y Elec Sys Taxable Gen Bds 2020 C Taxable 0.764% Dtd 08/20/2020 Due 03/01/2023 Callable	90,000.000	89,418.60 90,000.00	687.00 229.20	0.77%
Modesto Calif Irr Dist Fing Au Rev Bds 2015a 5.00% Dtd 07/15/2015 Due 10/01/2023 Non-Callable	90,000.000	91,416.60 94,106.30	4,500.00 1,125.00	4.92%
New Mexico St Severance Tax Tax Bds 2015 A 5.00% Dtd 08/12/2015 Due 07/01/2023 Non-Callable	70,000.000	70,704.20 73,255.80	3,500.00 1,749.99	4.95%
New York Life Gbl Fdg MTN 144a Sr Sec Gbl 1.10% Dtd 05/07/2020 Due 05/05/2023 Non-Callable	90,000.000	88,906.50 90,327.60	990.00 154.00	1.11%
San Juan Calif Uni Sch Dist Bds Zero Cpn Dtd 08/02/2001 Due 08/01/2023 Non-Callable	60,000.000	58,971.00 59,875.49	0.00	0.00%
Santa Ana Calif Uni Sch Dist Sch Dist Bds 2008 A Zero Cpn Dtd 08/19/2008 Due 08/01/2023 Non-Callable	125,000.000	122,648.75 124,690.37	0.00	0.00%



WBSD - CAPITAL PROJECT RESERVE

Account Number:
Statement Period:

61-J235-01-2
10/01/22 - 12/31/22

Asset Position As of 12/31/22

Asset Description	Units	Market Value Cost	Est. Annual Income Accruals	Current Yield
Synchrony Financial Sr Gbl Nt 4.25% Dtd 08/11/2014 Due 08/15/2024 Callable	135,000.000	131,900.40 141,790.95	5,737.00 2,167.50	4.35%
Tarkington Tex Indpt Sch Dist Taxable Unltd Tax Ref Bd Taxable Zero Cpn Dtd 02/01/2021 Due 02/15/2023 Non-Callable	125,000.000	124,320.00 124,936.21	0.00	0.00%
Tennessee Valley Auth Sr Gbl A Bd 0.75% Dtd 05/11/2020 Due 05/15/2025 Non-Callable	300,000.000	274,155.00 302,607.00	2,250.00 287.50	0.82%
Toyota Motor Credit Corp Fr 2.90% Dtd 04/01/2020 Due 03/30/2023 Non-Callable	20,000.000	19,920.60 20,192.40	580.00 146.61	2.91%
Toyota Motor Credit Corp Fr 3.00% Dtd 04/01/2020 Due 04/01/2025 Callable	50,000.000	48,012.50 52,797.50	1,500.00 375.00	3.12%
United Parcel Service Inc Sr Nt 2.50% Dtd 11/14/2017 Due 04/01/2023 Callable	90,000.000	89,455.50 90,843.30	2,250.00 562.50	2.52%
US Treasury Note 0.125% Dtd 09/15/2020 Due 09/15/2023	400,000.000	387,468.00 384,828.13	500.00 149.17	0.13%
US Treasury Note 0.125% Dtd 12/15/2020 Due 12/15/2023	160,000.000	153,276.80 155,160.64	200.00 9.34	0.13%
US Treasury Note 0.50% Dtd 02/28/2021 Due 02/28/2026	30,000.000	26,736.60 26,853.52	150.00 50.97	0.56%
US Treasury Note 0.75% Dtd 03/31/2021 Due 03/31/2026	160,000.000	143,425.60 159,125.00	1,200.00 306.59	0.84%
US Treasury Note 1.00% Dtd 12/15/2021 Due 12/15/2024	240,000.000	224,664.00 229,938.98	2,400.00 112.08	1.07%
US Treasury Note 0.875% Dtd 01/31/2022 Due 01/31/2024	60,000.000	57,597.60 58,544.32	525.00 219.70	0.91%
US Treasury Note 1.625% Dtd 02/15/2016 Due 02/15/2026	100,000.000	92,516.00 95,435.88	1,625.00 613.79	1.76%
US Treasury Note 1.625% Dtd 10/31/2016 Due 10/31/2023	350,000.000	341,334.00 350,342.57	5,687.00 974.10	1.67%
US Treasury Note 2.50% Dtd 05/15/2014 Due 05/15/2024	160,000.000	155,337.60 159,243.75	4,000.00 519.33	2.58%



WBSD - CAPITAL PROJECT RESERVE

Account Number:
Statement Period:

61-J235-01-2
10/01/22 - 12/31/22

Asset Position As of 12/31/22

Asset Description	Units	Market Value Cost	Est. Annual Income Accruals	Current Yield
US Treasury Note 2.00% Dtd 06/30/2017 Due 06/30/2024	100,000.000	96,200.00 98,405.32	2,000.00 5.52	2.08%
US Treasury Note 2.75% Dtd 06/30/2018 Due 06/30/2025	120,000.000	115,632.00 114,739.85	3,300.00 9.11	2.85%
US Treasury Note 1.625% Dtd 10/31/2019 Due 10/31/2026	200,000.000	182,602.00 183,875.00	3,250.00 556.63	1.78%
US Treasury Note 1.75% Dtd 12/31/2019 Due 12/31/2026	100,000.000	91,575.00 92,252.50	1,750.00 4.83	1.91%
US Treasury Note 1.875% Dtd 07/31/2019 Due 07/31/2026	200,000.000	185,000.00 186,265.62	3,750.00 1,569.29	2.03%
US Treasury Note 2.625% Dtd 02/28/2018 Due 02/28/2023	250,000.000	249,280.00 251,788.15	6,562.00 2,229.79	2.63%
US Treasury Note 2.625% Dtd 06/30/2018 Due 06/30/2023	250,000.000	247,615.00 251,561.83	6,562.00 18.12	2.65%
US Treasury Note 2.50% Dtd 01/31/2019 Due 01/31/2024	100,000.000	97,680.00 99,754.40	2,500.00 1,046.19	2.56%
US Treasury Note 2.375% Dtd 02/28/2019 Due 02/29/2024	300,000.000	292,254.00 303,441.36	7,125.00 2,420.92	2.44%
US Treasury Note 1.75% Dtd 06/30/2019 Due 06/30/2024	140,000.000	134,181.60 133,804.42	2,450.00 6.76	1.83%
University Calif Revs Gen Rev Bds 2015 A Taxable 2.909% Dtd 03/25/2015 Due 05/15/2023 Callable	90,000.000	89,475.30 90,828.10	2,618.00 334.53	2.93%
Waco Tex Indpt Sch Dist Taxable Unltd Tax Ref Bd Taxable Zero Cpn Dtd 01/01/2021 Due 08/15/2024 Non-Callable	100,000.000	92,325.00 99,115.46	0.00	0.00%
Waco Tex Indpt Sch Dist Taxable Unltd Tax Ref Bd Taxable Zero Cpn Dtd 01/01/2021 Due 08/15/2025 Non-Callable	300,000.000	263,289.00 294,368.80	0.00	0.00%
Washington St Motor Veh Fuel Tax B 2003 C Zero Cpn Dtd 10/02/2002 Due 06/01/2023 Non-Callable	40,000.000	39,497.20 39,941.46	0.00	0.00%
Total Fixed Income		\$ 6,230,901.75 \$ 6,480,173.08	112,251.00 25,304.63	1.80%



WBSD - CAPITAL PROJECT RESERVE

Account Number:
 Statement Period:

61-J235-01-2
 10/01/22 - 12/31/22

Asset Position As of 12/31/22

Asset Description	Units	Market Value Cost	Est. Annual Income Accruals	Current Yield
Cash				
Principal Cash		0.00 0.00	0.00	0.00%
Income Cash		0.00 0.00	0.00	0.00%
Total Cash		\$ 0.00 \$ 0.00	0.00 0.00	0.00%
Total Market Value		\$ 6,269,190.26 \$ 6,518,461.59	113,839.00 25,587.02	1.82%
Total Market Value Plus Accruals		\$ 6,294,777.28		

Income Activity

	Date	Income Cash	Principal Cash
Interest Income			
Bank of The West Advantage Acct			
Int To 09/30/22	10/03/22		609.57
Int To 10/31/22	11/01/22		604.25
Int To 11/30/22	12/01/22		248.07
American Express Co Sr Gbl Nt 3.00% Dtd 10/30/2017 Due 10/30/2024 Callable			
Int To 10/30/22 on 90,000	10/31/22		1,350.00
Apple Inc Sr Gbl Nt 0.75% Dtd 05/11/2020 Due 05/11/2023 Callable			
Int To 11/11/22 on 10,000	11/11/22		37.50
Clackamas Cnty Ore Sch Dist No GO Bds B 5.00% Dtd 03/02/2017 Due 06/15/2023 Non-Callable			
Int To 12/15/22 on 70,000	12/15/22		1,750.00
Federal Home Loan Bks Cons Bds 0.60% Dtd 04/30/2021 Due 12/30/2024 Callable			
Int To 10/30/22 on 50,000	10/31/22		150.00



WBSD - CAPITAL PROJECT RESERVE

Account Number:
 Statement Period:

61-J235-01-2
 10/01/22 - 12/31/22

Income Activity			
	Date	Income Cash	Principal Cash
Federal Home Loan Bks Cons Bds 0.60% Dtd 04/30/2021 Due 10/30/2024 Callable Int To 10/30/22 on 100,000	10/31/22		300.00
Federal Farm Cr Bks Cons Systemwide Bds 0.71% Dtd 04/21/2021 Due 04/21/2025 Callable Int To 10/21/22 on 300,000	10/21/22		1,065.00
Federal Natl Mtg Assn Gtd Passthru CTF Pool #AN4889 2.750% Dtd 03/01/2017 Due 03/01/2024 IPD24 Int For September 2022 on 200000	10/25/22		458.33
Int For October 2022 on 200000	11/25/22		473.61
Int For November 2022 on 200000	12/27/22		458.33
Kla Tencor Corp Sr Gbl Nt 4.65% Dtd 11/06/2014 Due 11/01/2024 Callable Int To 11/01/22 on 50,000	11/01/22		1,162.50
Modesto Calif Irr Dist Fing Au Rev Bds 2015a 5.00% Dtd 07/15/2015 Due 10/01/2023 Non-Callable Int To 10/01/22 on 90,000	10/03/22		2,250.00
New York Life Gbl Fdg MTN 144a Sr Sec Gbl 1.10% Dtd 05/07/2020 Due 05/05/2023 Non-Callable Int To 11/05/22 on 90,000	11/07/22		495.00
Tennessee Valley Auth Sr Gbl A Bd 0.75% Dtd 05/11/2020 Due 05/15/2025 Non-Callable Int To 11/15/22 on 300,000	11/15/22		1,125.00
Toyota Motor Credit Corp Fr 3.00% Dtd 04/01/2020 Due 04/01/2025 Callable Int To 10/01/22 on 50,000	10/03/22		750.00
United Parcel Service Inc Sr Nt 2.50% Dtd 11/14/2017 Due 04/01/2023 Callable Int To 10/01/22 on 90,000	10/03/22		1,125.00
US Treasury Bill Due 10/06/2022 Interest on Maturity of 200,000	10/06/22		988.00



WBSD - CAPITAL PROJECT RESERVE

Account Number:
 Statement Period:

61-J235-01-2
 10/01/22 - 12/31/22

Income Activity			
	Date	Income Cash	Principal Cash
US Treasury Note 0.125% Dtd 12/15/2020 Due 12/15/2023 Int To 12/15/22 on 160,000	12/15/22		100.00
US Treasury Note 1.00% Dtd 12/15/2021 Due 12/15/2024 Int To 12/15/22 on 240,000	12/15/22		1,200.00
US Treasury Note 1.625% Dtd 10/31/2016 Due 10/31/2023 Int To 10/31/22 on 350,000	10/31/22		2,843.75
US Treasury Note 2.50% Dtd 05/15/2014 Due 05/15/2024 Int To 11/15/22 on 160,000	11/15/22		2,000.00
US Treasury Note 2.00% Dtd 06/30/2017 Due 06/30/2024 Int To 12/31/22 on 100,000	12/30/22		1,000.00
US Treasury Note 2.75% Dtd 06/30/2018 Due 06/30/2025 Int To 12/31/22 on 120,000	12/30/22		1,650.00
US Treasury Note 1.75% Dtd 12/31/2019 Due 12/31/2026 Int To 12/31/22 on 100,000	12/30/22		875.00
US Treasury Note 2.625% Dtd 06/30/2018 Due 06/30/2023 Int To 12/31/22 on 250,000	12/30/22		3,281.25
US Treasury Note 1.75% Dtd 06/30/2019 Due 06/30/2024 Int To 12/31/22 on 140,000	12/30/22		1,225.00
University Calif Revs Gen Rev Bds 2015 A Taxable 2.909% Dtd 03/25/2015 Due 05/15/2023 Callable Int To 11/15/22 on 90,000	11/15/22		1,309.05
Total Interest Income		\$ 0.00	\$ 30,884.21
Purchased Income			
US Treasury Note 0.50% Dtd 02/28/2021 Due 02/28/2026 Accrued Int To 12/27/22 Paid on Purchase of 30,000	12/27/22		-48.90



WBSD - CAPITAL PROJECT RESERVE

Account Number:
 Statement Period:

61-J235-01-2
 10/01/22 - 12/31/22

Income Activity			
	Date	Income Cash	Principal Cash
US Treasury Note 2.75% Dtd 06/30/2018 Due 06/30/2025 Accrued Int To 11/08/22 Paid on Purchase of 120,000	11/08/22		-1,174.73
US Treasury Note 1.625% Dtd 10/31/2019 Due 10/31/2026 Accrued Int To 12/23/22 Paid on Purchase of 200,000	12/23/22		-475.83
US Treasury Note 1.75% Dtd 12/31/2019 Due 12/31/2026 Accrued Int To 12/23/22 Paid on Purchase of 100,000	12/23/22		-836.96
US Treasury Note 1.875% Dtd 07/31/2019 Due 07/31/2026 Accrued Int To 12/23/22 Paid on Purchase of 200,000	12/23/22		-1,477.58
US Treasury Note 1.75% Dtd 06/30/2019 Due 06/30/2024 Accrued Int To 11/08/22 Paid on Purchase of 140,000	11/08/22		-872.15
Total Purchased Income		\$ 0.00	\$ -4,886.15
Total Income		\$ 0.00	\$ 25,998.06

Additions			
	Date	Income Cash	Principal Cash
Miscellaneous Additions			
Addition To Account ACH Transfer From Botw Ckg Ending In 6049 Per Client Instructions: 12/15/22	12/20/22		479,000.00
Total Miscellaneous Additions		\$ 0.00	\$ 479,000.00
Total Additions		\$ 0.00	\$ 479,000.00



WBSD - CAPITAL PROJECT RESERVE

Account Number:
 Statement Period:

61-J235-01-2
 10/01/22 - 12/31/22

Disbursement Activity			
	Date	Income Cash	Principal Cash
Fees/Expenses			
Monthly Fee To 09/30/22	10/14/22		-827.84
Monthly Fee To 10/31/22	11/15/22		-827.74
Monthly Fee To 11/30/22	12/15/22		-831.21
Total Fees/Expenses		\$ 0.00	\$ -2,486.79
Total Disbursements		\$ 0.00	\$ -2,486.79

Purchase Activity			
	Date	Income Cash	Principal Cash
Bank of The West Advantage Acct Purchases (14) 10/01/22 To 12/31/22	12/31/22		-708,437.88
US Treasury Note 0.50% Dtd 02/28/2021 Due 02/28/2026 Purchased 30000 12/23/22 From Wells Fargo Securities, LLC @ 89.511718	12/27/22		-26,853.52
US Treasury Note 2.75% Dtd 06/30/2018 Due 06/30/2025 Purchased 120000 11/07/22 From Wells Fargo Securities, LLC @ 95.363281	11/08/22		-114,435.94
US Treasury Note 1.625% Dtd 10/31/2019 Due 10/31/2026 Purchased 200000 12/22/22 From Wells Fargo Securities, LLC @ 91.9375	12/23/22		-183,875.00
US Treasury Note 1.75% Dtd 12/31/2019 Due 12/31/2026 Purchased 100000 12/22/22 From BNY Mellon/Toronto Dominion Sec @ 92.214843	12/23/22		-92,214.84
US Treasury Note 1.875% Dtd 07/31/2019 Due 07/31/2026 Purchased 200000 12/22/22 From Morgan Stanley & Co @ 93.132812	12/23/22		-186,265.62



WBSD - CAPITAL PROJECT RESERVE

Account Number:
 Statement Period:

61-J235-01-2
 10/01/22 - 12/31/22

Purchase Activity			
	Date	Income Cash	Principal Cash
US Treasury Note 1.75% Dtd 06/30/2019 Due 06/30/2024 Purchased 140000 11/07/22 From Wells Fargo Securities, LLC @ 95.148437	11/08/22		-133,207.81
Total Purchases		\$ 0.00	\$ -1,445,290.61

Sale Activity			
	Date	Proceeds	Realized Gain/Loss
Bank of The West Advantage Acct Sales (6) 10/01/22 To 12/31/22	12/31/22	743,767.34	
US Treasury Bill Due 10/06/2022 Recd Proceeds on Maturity of 200,000 Par Value	10/06/22	199,012.00	
Total Sales		\$ 942,779.34	\$ 0.00

Non-Cash Activity		
	Date	Cost
American Express Co Sr Gbl Nt 3.00% Dtd 10/30/2017 Due 10/30/2024 Callable Amortization of Premium	10/28/22	-956.70
Apple Inc Sr Gbl Nt 0.75% Dtd 05/11/2020 Due 05/11/2023 Callable Amortization of Premium	11/11/22	-20.20
Clackamas Cnty Ore Sch Dist No GO Bds B 5.00% Dtd 03/02/2017 Due 06/15/2023 Non-Callable Amortization of Premium	12/15/22	-1,146.00
Amortization of Premium	12/15/22	-459.40
Kla Tencor Corp Sr Gbl Nt 4.65% Dtd 11/06/2014 Due 11/01/2024 Callable Amortization of Premium	11/01/22	-855.00



WBSD - CAPITAL PROJECT RESERVE

Account Number:
 Statement Period:

61-J235-01-2
 10/01/22 - 12/31/22

Non-Cash Activity

	Date	Cost
Modesto Calif Irr Dist Fing Au Rev		
Bds 2015a 5.00% Dtd 07/15/2015 Due		
10/01/2023 Non-Callable		
Amortization of Premium	10/03/22	-916.80
Amortization of Premium	10/03/22	-1,130.00
New York Life Gbl Fdg MTN 144a Sr		
Sec Gbl 1.10% Dtd 05/07/2020 Due		
05/05/2023 Non-Callable		
Amortization of Premium	11/04/22	-326.70
San Juan Calif Uni Sch Dist Bds		
Zero Cpn Dtd 08/02/2001 Due		
08/01/2023 Non-Callable		
Accretion of Discount	10/31/22	13.80
Accretion of Discount	10/31/22	3.86
Accretion of Discount	11/30/22	13.80
Accretion of Discount	11/30/22	3.86
Accretion of Discount	12/30/22	13.80
Accretion of Discount	12/30/22	3.86
Santa Ana Calif Uni Sch Dist Sch		
Dist Bds 2008 A Zero Cpn Dtd		
08/19/2008 Due 08/01/2023		
Non-Callable		
Accretion of Discount	10/31/22	29.03
Accretion of Discount	10/31/22	14.95
Accretion of Discount	11/30/22	29.03
Accretion of Discount	11/30/22	14.95
Accretion of Discount	12/30/22	29.03
Accretion of Discount	12/30/22	14.95
Tarkington Tex Indpt Sch Dist		
Taxable Unltd Tax Ref Bd Taxable		
Zero Cpn Dtd 02/01/2021 Due		
02/15/2023 Non-Callable		
Accretion of Discount	10/31/22	42.51
Accretion of Discount	11/30/22	42.51
Accretion of Discount	12/30/22	42.51
Tennessee Valley Auth Sr Gbl A Bd		
0.75% Dtd 05/11/2020 Due 05/15/2025		
Non-Callable		
Amortization of Premium	11/15/22	-259.50
Amortization of Premium	11/15/22	-259.50
Toyota Motor Credit Corp Fr		
3.00% Dtd 04/01/2020 Due 04/01/2025		
Callable		
Amortization of Premium	10/03/22	-553.50



WBSD - CAPITAL PROJECT RESERVE

Account Number:
Statement Period:

61-J235-01-2
10/01/22 - 12/31/22

Non-Cash Activity		
	Date	Cost
United Parcel Service Inc Sr Nt 2.50% Dtd 11/14/2017 Due 04/01/2023 Callable Amortization of Premium	10/03/22	-840.60
US Treasury Note 0.125% Dtd 12/15/2020 Due 12/15/2023 Accretion of Discount	12/15/22	1,666.89
US Treasury Note 1.00% Dtd 12/15/2021 Due 12/15/2024 Accretion of Discount	12/15/22	1,732.73
US Treasury Note 1.625% Dtd 10/31/2016 Due 10/31/2023 Amortization of Premium	10/31/22	-169.35
US Treasury Note 2.00% Dtd 06/30/2017 Due 06/30/2024 Accretion of Discount	12/30/22	499.07
US Treasury Note 2.75% Dtd 06/30/2018 Due 06/30/2025 Accretion of Discount	12/30/22	303.91
US Treasury Note 1.75% Dtd 12/31/2019 Due 12/31/2026 Accretion of Discount	12/30/22	37.66
US Treasury Note 2.625% Dtd 06/30/2018 Due 06/30/2023 Amortization of Premium	12/30/22	-1,551.22
US Treasury Note 1.75% Dtd 06/30/2019 Due 06/30/2024 Accretion of Discount	12/30/22	596.61
University Calif Revs Gen Rev Bds 2015 A Taxable 2.909% Dtd 03/25/2015 Due 05/15/2023 Callable Amortization of Premium	11/15/22	-516.10
Amortization of Premium	11/15/22	-308.00
Waco Tex Indpt Sch Dist Taxable Unltd Tax Ref Bd Taxable Zero Cpn Dtd 01/01/2021 Due 08/15/2024 Non-Callable Accretion of Discount	10/31/22	45.34
Accretion of Discount	11/30/22	45.34
Accretion of Discount	12/30/22	45.34



WBSD - CAPITAL PROJECT RESERVE

Account Number:
Statement Period:

61-J235-01-2
10/01/22 - 12/31/22

Non-Cash Activity

	Date	Cost
Waco Tex Indpt Sch Dist Taxable Unltd Tax Ref Bd Taxable Zero Cpn Dtd 01/01/2021 Due 08/15/2025 Non-Callable		
Accretion of Discount	10/31/22	89.38
Accretion of Discount	10/31/22	89.38
Accretion of Discount	11/30/22	89.38
Accretion of Discount	11/30/22	89.38
Accretion of Discount	12/30/22	89.38
Accretion of Discount	12/30/22	89.38
Washington St Motor Veh Fuel Tax B 2003 C Zero Cpn Dtd 10/02/2002 Due 06/01/2023 Non-Callable		
Accretion of Discount	10/31/22	11.62
Accretion of Discount	11/30/22	11.62
Accretion of Discount	12/30/22	11.62
Total Non-Cash Transactions		\$ -4,412.09

SECURITY PRICES CONTAINED IN THIS STATEMENT ARE OBTAINED FROM THE MOST RELIABLE SOURCES AVAILABLE BUT ARE NOT GUARANTEED BY BANK OF THE WEST. QUOTED PRICES MAY NOT EQUAL ACTUAL PRICES BECAUSE OF SECURITY SIZE, MARKET PRICE, TERM AND DEMAND.



Electronic Funds Transfers

Preauthorized Transfers:

You may request an electronic fund transfer (EFT), such as an ACH transfer from or deposit to your account, by contacting your account Administrator. You may also preauthorize periodic EFTs by contacting your account Administrator. If you would like to know whether a preauthorized EFT has occurred, please contact your account Administrator at the phone number listed on the first page of your statement. TTY 1-866-936-2689, Monday - Friday, 8 a.m. - 4:30 p.m. Central Time.

Error Resolution Notice:

If you think a statement or receipt is wrong or if you need more information about an EFT listed on a statement or receipt, telephone your account Administrator at the phone number listed on the first page of your statement, TTY 1-866-936-2689, Monday - Friday, 8 a.m. - 4:30 p.m. Central Time, write to us at Bank of the West, GIFS Operations, 12000 North Washington Street, Suite, 300, Thornton, CO 80241 or e-mail us at WMGGIFSOperations@bankofthewest.com as soon as possible. We must hear from you no later than 60 days after we sent the FIRST statement on which the problem or error appeared.

1. Tell us your name and account number (if any).
2. Tell us the dollar amount of the suspected error.
3. Describe the error or the transfer you are unsure about, and explain as clearly as you can why you believe it is an error or why you need more information.

If you contact us verbally, we may require that you send us your complaint or question in writing within 10 business days. We will investigate your complaint and will correct any error promptly. If we take more than 10 business days to do this, we will credit your account for the amount you think is in error, so that you will have the use of the money during the time it takes us to complete our investigation.



WBSD - EMERGENCY CAPITAL RESERVE

Account Number: 61-J004-01-2
 Statement Period: 10/01/22 - 12/31/22

WEST BAY SANITARY DISTRICT
 500 LAUREL STREET
 MENLO PARK CA 94025

Fiduciary
 Chuen Ying Lee
 (408) 645-3234
Portfolio
 Michael D. Smith
 (408) 490-2079

Asset Allocation

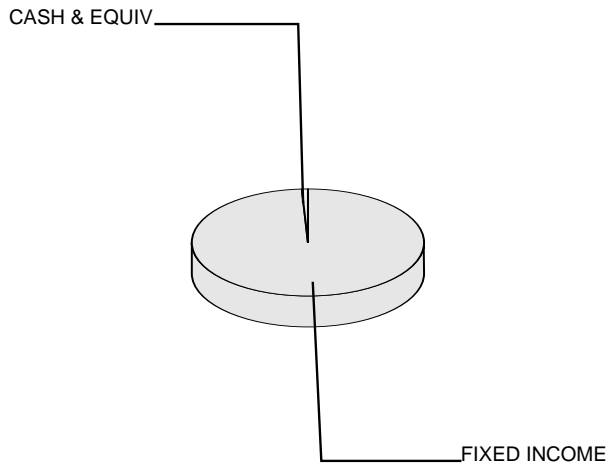

Asset Valuation

Description	Market Value	% of Account
Cash & Equiv	33,495.16	0.6%
Fixed Income	5,189,107.11	99.4%
Total Portfolio	\$ 5,222,602.27	100.0%
Accrued Income	23,466.37	
Total Valuation	\$ 5,246,068.64	

Market Reconciliation

	Current Period	Year To Date
Beginning Market Value	\$ 4,828,445.46	\$ 4,877,961.83
Income		
Interest.....	30,375.02	59,299.19
Purchased Income.....	-4,106.77	-4,787.81
Additions.....	381,100.00	381,100.00
Disbursements.....	-2,077.93	-4,184.01
Realized Gains/(Losses).....	0.00	-522.32
Change In Accrued Income.....	-1,553.10	-4,639.94
Change In Market Appreciation/(Depreciation).....	22,434.04	-36,201.96
Non-Cash Asset Changes.....	-8,548.08	-21,956.34
Ending Market Value	\$ 5,246,068.64	\$ 5,246,068.64



WBSD - EMERGENCY CAPITAL RESERVE

Account Number:
Statement Period:

61-J004-01-2
10/01/22 - 12/31/22

Asset Position As of 12/31/22

Asset Description	Units	Market Value Cost	Est. Annual Income Accruals	Current Yield
Cash Equivalents				
Bank of The West Advantage Acct	33,495.160	33,495.16 33,495.16	1,390.00 258.74	4.15%
Total Cash Equivalents		\$ 33,495.16 \$ 33,495.16	1,390.00 258.74	4.15%
Fixed Income				
Anz National Intl LTD Fr 3.40% Dtd 03/19/2019 Due 03/19/2024 Non-Callable	50,000.000	48,928.00 51,936.50	1,700.00 481.66	3.47%
American Express Co Sr Gbl 2.50% Dtd 07/30/2019 Due 07/30/2024 Callable	100,000.000	96,171.00 102,828.00	2,500.00 1,048.61	2.60%
American Tower Corp Sr Gbl Nt 3.00% Dtd 12/08/2017 Due 06/15/2023 Callable	55,000.000	54,414.80 55,668.25	1,650.00 73.33	3.03%
Apple Inc Sr Gbl Nt 0.75% Dtd 05/11/2020 Due 05/11/2023 Callable	25,000.000	24,639.75 25,050.50	187.00 26.04	0.76%
Apple Inc Sr Gbl 0.70% Dtd 02/08/2021 Due 02/08/2026 Callable	50,000.000	44,379.00 49,948.00	350.00 139.02	0.79%
Asotin Cnty Wash Taxable GO LTD Tax Bds 2021 B Taxable 0.583% Dtd 02/25/2021 Due 12/01/2024 Non-Callable	100,000.000	92,500.00 100,000.00	583.00 48.58	0.63%
Beverly Hills Calif Uni Sch Di GO Bds Zero Cpn Dtd 02/10/2009 Due 08/01/2023 Non-Callable	50,000.000	49,142.50 49,889.10	0.00	0.00%
Blackrock Inc Sr Nt 3.50% Dtd 03/18/2014 Due 03/18/2024 Callable	100,000.000	98,366.00 104,268.50	3,500.00 1,001.38	3.56%
Cashmere Wash Wtr & Swr Rev Taxable Ref Bds 2021b Taxable 0.658% Dtd 02/24/2021 Due 12/01/2024 Non-Callable	100,000.000	92,540.00 100,000.00	658.00 54.83	0.71%



WBSD - EMERGENCY CAPITAL RESERVE

Account Number:
Statement Period:

61-J004-01-2
10/01/22 - 12/31/22

Asset Position As of 12/31/22

Asset Description	Units	Market Value Cost	Est. Annual Income Accruals	Current Yield
Comcast Corp New Sr Nt 3.375% Dtd 05/27/2015 Due 08/15/2025 Callable	55,000.000	53,050.25 59,111.25	1,856.00 701.25	3.50%
Deere John Capital Corp Fr 3.45% Dtd 03/13/2018 Due 03/13/2025 Non-Callable	40,000.000	38,934.40 42,796.40	1,380.00 413.99	3.54%
Deschutes Cnty Ore Administrat GO Bds 5.00% Dtd 08/31/2017 Due 06/15/2023 Non-Callable	45,000.000	45,419.85 46,015.20	2,250.00 100.00	4.95%
Federal Home Loan Bks Cons Bds 0.60% Dtd 04/30/2021 Due 12/30/2024 Callable	270,000.000	248,697.00 270,000.00	1,620.00 274.50	0.65%
Federal Home Loan Bks Cons Bds 0.60% Dtd 04/30/2021 Due 10/30/2024 Callable	100,000.000	92,641.00 100,000.00	600.00 101.66	0.65%
Federal Farm Cr Bks Cons Systemwide Bds 0.71% Dtd 04/21/2021 Due 04/21/2025 Callable	100,000.000	90,878.00 100,000.00	710.00 138.05	0.78%
Longview Tex Indpt Sch Dist Ultd Tax Ref Bds 5.00% Dtd 04/15/2016 Due 02/15/2023 Non-Callable	55,000.000	55,125.40 56,287.55	2,750.00 1,038.88	4.99%
Los Angeles Calif Mun Impt COR Bds 2019a 5.00% Dtd 06/26/2019 Due 11/01/2023 Non-Callable	65,000.000	66,114.10 67,249.65	3,250.00 541.66	4.92%
Mountain View Los Altos Calif GO Bds 2010a Zero Cpn Dtd 09/09/2010 Due 08/01/2023 Non-Callable	50,000.000	49,162.00 49,897.77	0.00	0.00%
New York Life Gbl Fdg MTN 144a Sr Sec Gbl 1.10% Dtd 05/07/2020 Due 05/05/2023 Non-Callable	50,000.000	49,392.50 50,181.50	550.00 85.55	1.11%
Oklahoma St Capitol Impt Auth Bds 2019 C 4.00% Dtd 09/10/2019 Due 01/01/2023 Non-Callable	50,000.000	50,000.00 50,885.50	2,000.00 1,000.00	4.00%
Paypal Hldgs Inc Sr Gbl 2.40% Dtd 09/26/2019 Due 10/01/2024 Callable	96,000.000	92,003.52 99,096.82	2,304.00 576.00	2.50%



WBSD - EMERGENCY CAPITAL RESERVE

Account Number:
 Statement Period:

61-J004-01-2
 10/01/22 - 12/31/22

Asset Position As of 12/31/22

Asset Description	Units	Market Value Cost	Est. Annual Income Accruals	Current Yield
Putnam Cnty Tenn GO Sch Bds 2.625% Dtd 06/06/2013 Due 04/01/2026 Prerefunded 04/01/2023 @ 100.000 Callable	45,000.000	44,955.45 45,516.60	1,181.00 295.31	2.63%
San Francisco Calif City & Cnt Wastewtr Rev Bds 2010b Taxable 4.75% Dtd 06/08/2010 Due 10/01/2023 Callable	70,000.000	70,074.20 72,932.40	3,325.00 831.24	4.74%
Small Business Admin Gtd Ln Pool Cffs 4.34% Dtd 03/17/2004 Due 03/01/2024 Callable	1,493.360	1,480.29 2,354.21	64.00 24.30	4.38%
State Str Corp Sr Sb Nt 3.10% Dtd 05/15/2013 Due 05/15/2023 Non-Callable	100,000.000	99,332.00 101,298.00	3,100.00 396.11	3.12%
Synchrony Financial Sr Gbl Nt 4.25% Dtd 08/11/2014 Due 08/15/2024 Callable	55,000.000	53,737.20 57,763.75	2,337.00 883.05	4.35%
Tamalpais Calif Un High Sch Di GO Ref Bds 5.00% Dtd 11/25/2014 Due 08/01/2023 Non-Callable	60,000.000	60,725.40 62,767.80	3,000.00 1,249.99	4.94%
Tennessee Valley Auth Sr Gbl A Bd 0.75% Dtd 05/11/2020 Due 05/15/2025 Non-Callable	100,000.000	91,385.00 100,869.00	750.00 95.83	0.82%
Global Pmts Inc Sr Gbl Nt 4.00% Dtd 05/11/2018 Due 06/01/2023 Callable	75,000.000	74,547.00 76,255.50	3,000.00 249.99	4.02%
Toyota Motor Credit Corp Fr 2.90% Dtd 04/01/2020 Due 03/30/2023 Non-Callable	90,000.000	89,642.70 90,867.00	2,610.00 659.75	2.91%
Toyota Motor Credit Corp Fr 3.00% Dtd 04/01/2020 Due 04/01/2025 Callable	80,000.000	76,820.00 84,320.80	2,400.00 600.00	3.12%
United Parcel Service Inc Sr Nt 2.50% Dtd 11/14/2017 Due 04/01/2023 Callable	100,000.000	99,395.00 100,932.00	2,500.00 624.99	2.52%
US Treasury Note 0.125% Dtd 09/15/2020 Due 09/15/2023	200,000.000	193,734.00 192,414.06	250.00 74.59	0.13%
US Treasury Note 0.125% Dtd 12/15/2020 Due 12/15/2023	60,000.000	57,478.80 58,185.24	75.00 3.50	0.13%



WBSD - EMERGENCY CAPITAL RESERVE

Account Number:
Statement Period:

61-J004-01-2
10/01/22 - 12/31/22

Asset Position As of 12/31/22

Asset Description	Units	Market Value Cost	Est. Annual Income Accruals	Current Yield
US Treasury Note 0.50% Dtd 02/28/2021 Due 02/28/2026	20,000.000	17,824.40 17,902.34	100.00 33.98	0.56%
US Treasury Note 0.375% Dtd 08/15/2021 Due 08/15/2024	100,000.000	93,438.00 94,111.77	375.00 141.64	0.40%
US Treasury Note 0.50% Dtd 11/30/2021 Due 11/30/2023	50,000.000	48,107.50 48,733.24	250.00 21.97	0.52%
US Treasury Note 1.00% Dtd 12/15/2021 Due 12/15/2024	120,000.000	112,332.00 114,969.49	1,200.00 56.04	1.07%
US Treasury Note 0.875% Dtd 01/31/2022 Due 01/31/2024	100,000.000	95,996.00 96,713.30	875.00 366.16	0.91%
US Treasury Note 2.25% Dtd 03/31/2022 Due 03/31/2024	50,000.000	48,519.50 49,738.70	1,125.00 287.43	2.32%
US Treasury Note 1.625% Dtd 02/15/2016 Due 02/15/2026	200,000.000	185,032.00 190,871.76	3,250.00 1,227.58	1.76%
US Treasury Note 1.625% Dtd 10/31/2016 Due 10/31/2023	250,000.000	243,810.00 250,244.70	4,062.00 695.78	1.67%
US Treasury Note 2.50% Dtd 05/15/2014 Due 05/15/2024	120,000.000	116,503.20 119,432.81	3,000.00 389.50	2.58%
US Treasury Note 2.00% Dtd 06/30/2017 Due 06/30/2024	100,000.000	96,200.00 98,405.32	2,000.00 5.52	2.08%
US Treasury Note 2.75% Dtd 06/30/2018 Due 06/30/2025	140,000.000	134,904.00 133,863.16	3,850.00 10.63	2.85%
US Treasury Note 1.625% Dtd 10/31/2019 Due 10/31/2026	100,000.000	91,301.00 91,937.50	1,625.00 278.31	1.78%
US Treasury Note 1.875% Dtd 07/31/2019 Due 07/31/2026	100,000.000	92,500.00 93,132.81	1,875.00 784.64	2.03%
US Treasury Note 2.625% Dtd 02/28/2018 Due 02/28/2023	100,000.000	99,712.00 100,715.26	2,625.00 891.91	2.63%
US Treasury Note 2.625% Dtd 06/30/2018 Due 06/30/2023	250,000.000	247,615.00 251,561.83	6,562.00 18.12	2.65%
US Treasury Note 2.50% Dtd 01/31/2019 Due 01/31/2024	200,000.000	195,360.00 199,508.82	5,000.00 2,092.39	2.56%
US Treasury Note 2.375% Dtd 02/28/2019 Due 02/29/2024	150,000.000	146,127.00 151,720.68	3,562.00 1,210.46	2.44%



WBSD - EMERGENCY CAPITAL RESERVE

Account Number:
 Statement Period:

61-J004-01-2
 10/01/22 - 12/31/22

Asset Position As of 12/31/22

Asset Description	Units	Market Value Cost	Est. Annual Income Accruals	Current Yield
US Treasury Note 2.375% Dtd 04/30/2019 Due 04/30/2026	210,000.000	198,418.50 199,606.64	4,987.00 854.20	2.51%
US Treasury Note 1.75% Dtd 06/30/2019 Due 06/30/2024	160,000.000	153,350.40 152,919.34	2,800.00 7.73	1.83%
Waco Tex Indpt Sch Dist Taxable Unltd Tax Ref Bd Taxable Zero Cpn Dtd 01/01/2021 Due 08/15/2024 Non-Callable	150,000.000	138,487.50 148,673.40	0.00	0.00%
Waco Tex Indpt Sch Dist Taxable Unltd Tax Ref Bd Taxable Zero Cpn Dtd 01/01/2021 Due 08/15/2025 Non-Callable	100,000.000	87,763.00 98,122.79	0.00	0.00%
Total Fixed Income		\$ 5,189,107.11 \$ 5,380,472.51	104,113.00 23,207.63	2.01%
Cash				
Principal Cash		0.00 0.00	0.00	0.00%
Income Cash		0.00 0.00	0.00	0.00%
Total Cash		\$ 0.00 \$ 0.00	0.00 0.00	0.00%
Total Market Value		\$ 5,222,602.27 \$ 5,413,967.67	105,503.00 23,466.37	2.02%
Total Market Value Plus Accruals		\$ 5,246,068.64		

Income Activity

	Date	Income Cash	Principal Cash
Interest Income			
Bank of The West Advantage Acct			
Int To 09/30/22	10/03/22		362.36
Int To 10/31/22	11/01/22		727.86
Int To 11/30/22	12/01/22		283.91



WBSD - EMERGENCY CAPITAL RESERVE

Account Number:
 Statement Period:

61-J004-01-2
 10/01/22 - 12/31/22

Income Activity			
	Date	Income Cash	Principal Cash
American Tower Corp Sr Gbl Nt 3.00% Dtd 12/08/2017 Due 06/15/2023 Callable Int To 12/15/22 on 55,000	12/15/22		825.00
Apple Inc Sr Gbl Nt 0.75% Dtd 05/11/2020 Due 05/11/2023 Callable Int To 11/11/22 on 25,000	11/11/22		93.75
Asotin Cnty Wash Taxable GO LTD Tax Bds 2021 B Taxable 0.583% Dtd 02/25/2021 Due 12/01/2024 Non-Callable Int To 12/01/22 on 100,000	12/01/22		291.50
Cashmere Wash Wtr & Swr Rev Taxable Ref Bds 2021b Taxable 0.658% Dtd 02/24/2021 Due 12/01/2024 Non-Callable Int To 12/01/22 on 100,000	12/01/22		329.00
Deschutes Cnty Ore Administrat GO Bds 5.00% Dtd 08/31/2017 Due 06/15/2023 Non-Callable Int To 12/15/22 on 45,000	12/15/22		1,125.00
Federal Home Loan Bks Cons Bds 0.60% Dtd 04/30/2021 Due 12/30/2024 Callable Int To 10/30/22 on 270,000	10/31/22		810.00
Federal Home Loan Bks Cons Bds 0.60% Dtd 04/30/2021 Due 10/30/2024 Callable Int To 10/30/22 on 100,000	10/31/22		300.00
Federal Farm Cr Bks Cons Systemwide Bds 0.71% Dtd 04/21/2021 Due 04/21/2025 Callable Int To 10/21/22 on 100,000	10/21/22		355.00
Los Angeles Calif Mun Impt COR Bds 2019a 5.00% Dtd 06/26/2019 Due 11/01/2023 Non-Callable Int To 11/01/22 on 65,000	11/01/22		1,625.00
New York Life Gbl Fdg MTN 144a Sr Sec Gbl 1.10% Dtd 05/07/2020 Due 05/05/2023 Non-Callable Int To 11/05/22 on 50,000	11/07/22		275.00



WBSD - EMERGENCY CAPITAL RESERVE

Account Number:
 Statement Period:

61-J004-01-2
 10/01/22 - 12/31/22

Income Activity			
	Date	Income Cash	Principal Cash
New York N Y GO Bds Subser Taxable 4.669% Dtd 10/15/2009 Due 10/01/2022 Callable Int To 10/01/22 on 45,000	10/03/22		1,050.52
Paypal Hldgs Inc Sr Gbl 2.40% Dtd 09/26/2019 Due 10/01/2024 Callable Int To 10/01/22 on 96,000	10/03/22		1,152.00
Putnam Cnty Tenn GO Sch Bds 2.625% Dtd 06/06/2013 Due 04/01/2026 Prerefunded 04/01/2023 @ 100.000 Callable Int To 10/01/22 on 45,000	10/03/22		590.62
San Francisco Calif City & Cnt Wastewtr Rev Bds 2010b Taxable 4.75% Dtd 06/08/2010 Due 10/01/2023 Callable Int To 10/01/22 on 70,000	10/03/22		1,662.50
State Str Corp Sr Sb Nt 3.10% Dtd 05/15/2013 Due 05/15/2023 Non-Callable Int To 11/15/22 on 100,000	11/15/22		1,550.00
Tennessee Valley Auth Sr Gbl A Bd 0.75% Dtd 05/11/2020 Due 05/15/2025 Non-Callable Int To 11/15/22 on 100,000	11/15/22		375.00
Global Pmts Inc Sr Gbl Nt 4.00% Dtd 05/11/2018 Due 06/01/2023 Callable Int To 12/01/22 on 75,000	12/01/22		1,500.00
Toyota Motor Credit Corp Fr 3.00% Dtd 04/01/2020 Due 04/01/2025 Callable Int To 10/01/22 on 80,000	10/03/22		1,200.00
United Parcel Service Inc Sr Nt 2.50% Dtd 11/14/2017 Due 04/01/2023 Callable Int To 10/01/22 on 100,000	10/03/22		1,250.00
US Treasury Bill Due 10/06/2022 Interest on Maturity of 150,000	10/06/22		741.00



WBSD - EMERGENCY CAPITAL RESERVE

Account Number:
 Statement Period:

61-J004-01-2
 10/01/22 - 12/31/22

Income Activity			
	Date	Income Cash	Principal Cash
US Treasury Note 0.125% Dtd 12/15/2020 Due 12/15/2023 Int To 12/15/22 on 60,000	12/15/22		37.50
US Treasury Note 0.50% Dtd 11/30/2021 Due 11/30/2023 Int To 11/30/22 on 50,000	11/30/22		125.00
US Treasury Note 1.00% Dtd 12/15/2021 Due 12/15/2024 Int To 12/15/22 on 120,000	12/15/22		600.00
US Treasury Note 1.625% Dtd 10/31/2016 Due 10/31/2023 Int To 10/31/22 on 250,000	10/31/22		2,031.25
US Treasury Note 2.50% Dtd 05/15/2014 Due 05/15/2024 Int To 11/15/22 on 120,000	11/15/22		1,500.00
US Treasury Note 2.00% Dtd 06/30/2017 Due 06/30/2024 Int To 12/31/22 on 100,000	12/30/22		1,000.00
US Treasury Note 2.75% Dtd 06/30/2018 Due 06/30/2025 Int To 12/31/22 on 140,000	12/30/22		1,925.00
US Treasury Note 2.625% Dtd 06/30/2018 Due 06/30/2023 Int To 12/31/22 on 250,000	12/30/22		3,281.25
US Treasury Note 1.75% Dtd 06/30/2019 Due 06/30/2024 Int To 12/31/22 on 160,000	12/30/22		1,400.00
Total Interest Income		\$ 0.00	\$ 30,375.02
Purchased Income			
US Treasury Note 0.50% Dtd 02/28/2021 Due 02/28/2026 Accrued Int To 12/27/22 Paid on Purchase of 20,000	12/27/22		-32.60
US Treasury Note 2.75% Dtd 06/30/2018 Due 06/30/2025 Accrued Int To 11/08/22 Paid on Purchase of 140,000	11/08/22		-1,370.52



WBSD - EMERGENCY CAPITAL RESERVE

Account Number:
 Statement Period:

61-J004-01-2
 10/01/22 - 12/31/22

Income Activity			
	Date	Income Cash	Principal Cash
US Treasury Note 1.625% Dtd 10/31/2019 Due 10/31/2026 Accrued Int To 12/23/22 Paid on Purchase of 100,000	12/23/22		-237.91
US Treasury Note 1.875% Dtd 07/31/2019 Due 07/31/2026 Accrued Int To 12/23/22 Paid on Purchase of 100,000	12/23/22		-738.79
US Treasury Note 2.375% Dtd 04/30/2019 Due 04/30/2026 Accrued Int To 12/23/22 Paid on Purchase of 210,000	12/23/22		-730.21
US Treasury Note 1.75% Dtd 06/30/2019 Due 06/30/2024 Accrued Int To 11/08/22 Paid on Purchase of 160,000	11/08/22		-996.74
Total Purchased Income		\$ 0.00	\$ -4,106.77
Total Income		\$ 0.00	\$ 26,268.25

Additions			
	Date	Income Cash	Principal Cash
Miscellaneous Additions			
Addition To Account ACH Transfer From Botw Ckg Ending In 6049 Per Client Instructions: 12/15/22	12/20/22		381,100.00
Total Miscellaneous Additions		\$ 0.00	\$ 381,100.00
Total Additions		\$ 0.00	\$ 381,100.00

Disbursement Activity			
	Date	Income Cash	Principal Cash
Fees/Expenses			
Monthly Fee To 09/30/22	10/14/22		-691.57
Monthly Fee To 10/31/22	11/15/22		-691.77



WBSD - EMERGENCY CAPITAL RESERVE

Account Number:
 Statement Period:

61-J004-01-2
 10/01/22 - 12/31/22

Disbursement Activity			
	Date	Income Cash	Principal Cash
Monthly Fee To 11/30/22	12/15/22		-694.59
Total Fees/Expenses		\$ 0.00	\$ -2,077.93
Total Disbursements		\$ 0.00	\$ -2,077.93

Purchase Activity			
	Date	Income Cash	Principal Cash
Bank of The West Advantage Acct Purchases (13) 10/01/22 To 12/31/22	12/31/22		-605,734.02
US Treasury Note 0.50% Dtd 02/28/2021 Due 02/28/2026 Purchased 20000 12/23/22 From Wells Fargo Securities, LLC @ 89.511718	12/27/22		-17,902.34
US Treasury Note 2.75% Dtd 06/30/2018 Due 06/30/2025 Purchased 140000 11/07/22 From Wells Fargo Securities, LLC @ 95.363281	11/08/22		-133,508.59
US Treasury Note 1.625% Dtd 10/31/2019 Due 10/31/2026 Purchased 100000 12/22/22 From Wells Fargo Securities, LLC @ 91.9375	12/23/22		-91,937.50
US Treasury Note 1.875% Dtd 07/31/2019 Due 07/31/2026 Purchased 100000 12/22/22 From Morgan Stanley & Co @ 93.132812	12/23/22		-93,132.81
US Treasury Note 2.375% Dtd 04/30/2019 Due 04/30/2026 Purchased 210000 12/22/22 From Wells Fargo Securities, LLC @ 95.050781	12/23/22		-199,606.64
US Treasury Note 1.75% Dtd 06/30/2019 Due 06/30/2024 Purchased 160000 11/07/22 From Wells Fargo Securities, LLC @ 95.148437	11/08/22		-152,237.50
Total Purchases		\$ 0.00	\$ -1,294,059.40



WBSD - EMERGENCY CAPITAL RESERVE

Account Number:
 Statement Period:

61-J004-01-2
 10/01/22 - 12/31/22

Sale Activity			
	Date	Proceeds	Realized Gain/Loss
Bank of The West Advantage Acct Sales (6) 10/01/22 To 12/31/22	12/31/22	694,510.08	
New York N Y GO Bds Subser Taxable 4.669% Dtd 10/15/2009 Due 10/01/2022 Callable Recd Proceeds on Maturity of 45,000 Par Value	10/03/22	45,000.00	
US Treasury Bill Due 10/06/2022 Recd Proceeds on Maturity of 150,000 Par Value	10/06/22	149,259.00	
Total Sales		\$ 888,769.08	\$ 0.00

Non-Cash Activity		
	Date	Cost
American Tower Corp Sr Gbl Nt 3.00% Dtd 12/08/2017 Due 06/15/2023 Callable Amortization of Premium	12/15/22	-666.60
Apple Inc Sr Gbl Nt 0.75% Dtd 05/11/2020 Due 05/11/2023 Callable Amortization of Premium	11/11/22	-50.50
Beverly Hills Calif Uni Sch Di GO Bds Zero Cpn Dtd 02/10/2009 Due 08/01/2023 Non-Callable Accretion of Discount	10/31/22	15.75
Accretion of Discount	11/30/22	15.75
Accretion of Discount	12/30/22	15.75
Deschutes Cnty Ore Administrat GO Bds 5.00% Dtd 08/31/2017 Due 06/15/2023 Non-Callable Amortization of Premium	12/15/22	-1,012.95
Los Angeles Calif Mun Impt COR Bds 2019a 5.00% Dtd 06/26/2019 Due 11/01/2023 Non-Callable Amortization of Premium	11/01/22	-1,026.60
Amortization of Premium	11/01/22	-85.55
Mountain View Los Altos Calif GO Bds 2010a Zero Cpn Dtd 09/09/2010 Due 08/01/2023 Non-Callable Accretion of Discount	10/31/22	14.50



WBSD - EMERGENCY CAPITAL RESERVE

Account Number:
Statement Period:

61-J004-01-2
10/01/22 - 12/31/22

Non-Cash Activity

	Date	Cost
Accretion of Discount	11/30/22	14.50
Accretion of Discount	12/30/22	14.50
New York Life Gbl Fdg MTN 144a Sr Sec Gbl 1.10% Dtd 05/07/2020 Due 05/05/2023 Non-Callable Amortization of Premium	11/04/22	-181.00
New York N Y GO Bds Subser Taxable 4.669% Dtd 10/15/2009 Due 10/01/2022 Callable Amortization of Premium	10/03/22	-594.45
Paypal Hldgs Inc Sr Gbl 2.40% Dtd 09/26/2019 Due 10/01/2024 Callable Amortization of Premium	10/03/22	-451.00
Amortization of Premium	10/03/22	-316.52
Putnam Cnty Tenn GO Sch Bds 2.625% Dtd 06/06/2013 Due 04/01/2026 Prerefunded 04/01/2023 @ 100.000 Callable Amortization of Premium	10/03/22	-515.70
San Francisco Calif City & Cnt Wastewtr Rev Bds 2010b Taxable 4.75% Dtd 06/08/2010 Due 10/01/2023 Callable Amortization of Premium	10/03/22	-1,249.80
Amortization of Premium	10/03/22	-210.80
State Str Corp Sr Sb Nt 3.10% Dtd 05/15/2013 Due 05/15/2023 Non-Callable Amortization of Premium	11/15/22	-651.50
Amortization of Premium	11/15/22	-644.50
Tennessee Valley Auth Sr Gbl A Bd 0.75% Dtd 05/11/2020 Due 05/15/2025 Non-Callable Amortization of Premium	11/15/22	-173.00
Global Pmts Inc Sr Gbl Nt 4.00% Dtd 05/11/2018 Due 06/01/2023 Callable Amortization of Premium	12/01/22	-1,251.00
Toyota Motor Credit Corp Fr 3.00% Dtd 04/01/2020 Due 04/01/2025 Callable Amortization of Premium	10/03/22	-411.20
Amortization of Premium	10/03/22	-442.80



WBSD - EMERGENCY CAPITAL RESERVE

Account Number:
Statement Period:

61-J004-01-2
10/01/22 - 12/31/22

Non-Cash Activity		
	Date	Cost
United Parcel Service Inc Sr Nt 2.50% Dtd 11/14/2017 Due 04/01/2023 Callable Amortization of Premium	10/03/22	-930.00
US Treasury Note 0.125% Dtd 12/15/2020 Due 12/15/2023 Accretion of Discount	12/15/22	625.08
US Treasury Note 0.50% Dtd 11/30/2021 Due 11/30/2023 Accretion of Discount	11/30/22	489.10
US Treasury Note 1.00% Dtd 12/15/2021 Due 12/15/2024 Accretion of Discount	12/15/22	866.36
US Treasury Note 1.625% Dtd 10/31/2016 Due 10/31/2023 Amortization of Premium	10/31/22	-120.96
US Treasury Note 2.00% Dtd 06/30/2017 Due 06/30/2024 Accretion of Discount	12/30/22	499.07
US Treasury Note 2.75% Dtd 06/30/2018 Due 06/30/2025 Accretion of Discount	12/30/22	354.57
US Treasury Note 2.625% Dtd 06/30/2018 Due 06/30/2023 Amortization of Premium	12/30/22	-1,551.22
US Treasury Note 1.75% Dtd 06/30/2019 Due 06/30/2024 Accretion of Discount	12/30/22	681.84
Waco Tex Indpt Sch Dist Taxable Unltd Tax Ref Bd Taxable Zero Cpn Dtd 01/01/2021 Due 08/15/2024 Non-Callable Accretion of Discount	10/31/22	68.02
Accretion of Discount	11/30/22	68.02
Accretion of Discount	12/30/22	68.02



WBSD - EMERGENCY CAPITAL RESERVE

Account Number:
 Statement Period:

61-J004-01-2
 10/01/22 - 12/31/22

Non-Cash Activity

	Date	Cost
Waco Tex Indpt Sch Dist Taxable Unltd Tax Ref Bd Taxable Zero Cpn Dtd 01/01/2021 Due 08/15/2025 Non-Callable		
Accretion of Discount	10/31/22	59.58
Accretion of Discount	11/30/22	59.58
Accretion of Discount	12/30/22	59.58
Total Non-Cash Transactions		\$ -8,548.08

SECURITY PRICES CONTAINED IN THIS STATEMENT ARE OBTAINED FROM THE MOST RELIABLE SOURCES AVAILABLE BUT ARE NOT GUARANTEED BY BANK OF THE WEST. QUOTED PRICES MAY NOT EQUAL ACTUAL PRICES BECAUSE OF SECURITY SIZE, MARKET PRICE, TERM AND DEMAND.



Electronic Funds Transfers

Preauthorized Transfers:

You may request an electronic fund transfer (EFT), such as an ACH transfer from or deposit to your account, by contacting your account Administrator. You may also preauthorize periodic EFTs by contacting your account Administrator. If you would like to know whether a preauthorized EFT has occurred, please contact your account Administrator at the phone number listed on the first page of your statement. TTY 1-866-936-2689, Monday - Friday, 8 a.m. - 4:30 p.m. Central Time.

Error Resolution Notice:

If you think a statement or receipt is wrong or if you need more information about an EFT listed on a statement or receipt, telephone your account Administrator at the phone number listed on the first page of your statement, TTY 1-866-936-2689, Monday - Friday, 8 a.m. - 4:30 p.m. Central Time, write to us at Bank of the West, GIFS Operations, 12000 North Washington Street, Suite, 300, Thornton, CO 80241 or e-mail us at WMGGIFSOperations@bankofthewest.com as soon as possible. We must hear from you no later than 60 days after we sent the FIRST statement on which the problem or error appeared.

1. Tell us your name and account number (if any).
2. Tell us the dollar amount of the suspected error.
3. Describe the error or the transfer you are unsure about, and explain as clearly as you can why you believe it is an error or why you need more information.

If you contact us verbally, we may require that you send us your complaint or question in writing within 10 business days. We will investigate your complaint and will correct any error promptly. If we take more than 10 business days to do this, we will credit your account for the amount you think is in error, so that you will have the use of the money during the time it takes us to complete our investigation.



WBSD - RECYCLED WATER CASH FLOW

Account Number: 61-J260-01-0
 Statement Period: 10/01/22 - 12/31/22

WEST BAY SANITARY DISTRICT
 500 LAUREL STREET
 MENLO PARK CA 94025

Fiduciary
 Chuen Ying Lee
 (408) 645-3234
Portfolio
 Michael D. Smith
 (408) 490-2079

Asset Allocation

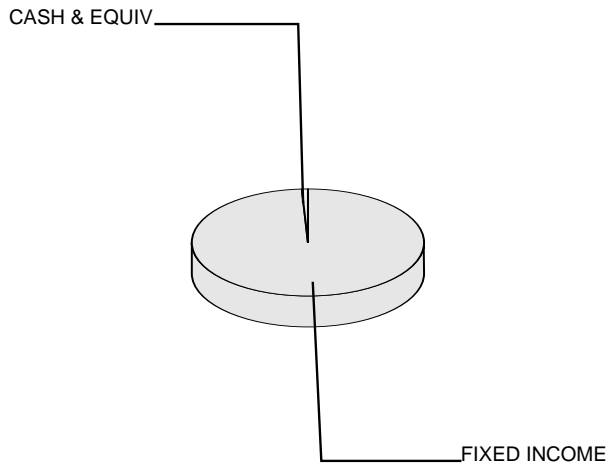

Asset Valuation

Description	Market Value	% of Account
Cash & Equiv	29,012.51	0.5%
Fixed Income	5,987,565.40	99.5%
Total Portfolio	\$ 6,016,577.91	100.0%
Accrued Income	27,577.99	
Total Valuation	\$ 6,044,155.90	

Market Reconciliation

	Current Period	Year To Date
Beginning Market Value	\$ 5,556,776.40	\$ 5,623,527.18
Income		
Interest.....	26,811.08	58,925.52
Purchased Income.....	-3,923.97	-3,939.82
Additions.....	456,100.00	456,100.00
Disbursements.....	-2,391.18	-4,818.49
Realized Gains/(Losses).....	0.00	0.00
Change In Accrued Income.....	6,018.35	2,308.66
Change In Market Appreciation/(Depreciation).....	5,760.28	-91,325.11
Non-Cash Asset Changes.....	-995.06	3,377.96
Ending Market Value	\$ 6,044,155.90	\$ 6,044,155.90



WBSD - RECYCLED WATER CASH FLOW

Account Number:
Statement Period:

61-J260-01-0
10/01/22 - 12/31/22

Asset Position As of 12/31/22

Asset Description	Units	Market Value Cost	Est. Annual Income Accruals	Current Yield
Cash Equivalents				
Bank of The West Advantage Acct	29,012.510	29,012.51 29,012.51	1,204.00 392.77	4.15%
Total Cash Equivalents		\$ 29,012.51 \$ 29,012.51	1,204.00 392.77	4.15%
Fixed Income				
Anz National Intl LTD Fr 3.40% Dtd 03/19/2019 Due 03/19/2024 Non-Callable	70,000.000	68,499.20 72,716.60	2,380.00 674.33	3.47%
BB&T Corp Sr Medium Term Nts Fr 3.70% Dtd 06/05/2018 Due 06/05/2025 Callable	15,000.000	14,583.60 16,057.50	555.00 40.08	3.81%
Blackrock Inc Sr Nt 3.50% Dtd 03/18/2014 Due 03/18/2024 Callable	70,000.000	68,856.20 73,131.70	2,450.00 700.97	3.56%
Comcast Corp New Sr Nt 3.375% Dtd 05/27/2015 Due 08/15/2025 Callable	30,000.000	28,936.50 32,248.20	1,012.00 382.50	3.50%
Federal Farm Cr Bks Cons Systemwide Bds 0.71% Dtd 04/21/2021 Due 04/21/2025 Callable	20,000.000	18,175.60 20,000.00	142.00 27.61	0.78%
Kla Tencor Corp Sr Glbl Nt 4.65% Dtd 11/06/2014 Due 11/01/2024 Callable	20,000.000	19,939.40 21,387.00	930.00 154.99	4.66%
Synchrony Financial Sr Glbl Nt 4.25% Dtd 08/11/2014 Due 08/15/2024 Callable	40,000.000	39,081.60 42,013.20	1,700.00 642.22	4.35%
US Treasury Note 0.125% Dtd 12/15/2020 Due 12/15/2023	20,000.000	19,159.60 19,395.08	25.00 1.16	0.13%
US Treasury Note 0.50% Dtd 02/28/2021 Due 02/28/2026	30,000.000	26,736.60 26,853.51	150.00 50.96	0.56%
US Treasury Note 0.75% Dtd 03/31/2021 Due 03/31/2026	20,000.000	17,928.20 19,896.88	150.00 38.32	0.84%
US Treasury Note 0.375% Dtd 08/15/2021 Due 08/15/2024	120,000.000	112,125.60 112,934.13	450.00 169.97	0.40%



WBSD - RECYCLED WATER CASH FLOW

Account Number:
Statement Period:

61-J260-01-0
10/01/22 - 12/31/22

Asset Position As of 12/31/22

Asset Description	Units	Market Value Cost	Est. Annual Income Accruals	Current Yield
US Treasury Note 0.875% Dtd 01/31/2022 Due 01/31/2024	1,600,000.000	1,535,936.00 1,561,181.92	14,000.00 5,858.69	0.91%
US Treasury Note 2.25% Dtd 03/31/2022 Due 03/31/2024	1,800,000.000	1,746,702.00 1,790,593.32	40,500.00 10,347.52	2.32%
US Treasury Note 1.625% Dtd 10/31/2016 Due 10/31/2023	50,000.000	48,762.00 50,048.94	812.00 139.15	1.67%
US Treasury Note 2.50% Dtd 05/15/2014 Due 05/15/2024	1,600,000.000	1,553,376.00 1,597,389.24	40,000.00 5,193.37	2.58%
US Treasury Note 2.00% Dtd 06/30/2017 Due 06/30/2024	20,000.000	19,240.00 19,681.06	400.00 1.10	2.08%
US Treasury Note 2.75% Dtd 06/30/2018 Due 06/30/2025	40,000.000	38,544.00 38,246.62	1,100.00 3.03	2.85%
US Treasury Note 1.75% Dtd 12/31/2019 Due 12/31/2026	150,000.000	137,362.50 138,378.76	2,625.00 7.25	1.91%
US Treasury Note 1.875% Dtd 07/31/2019 Due 07/31/2026	200,000.000	185,000.00 186,265.63	3,750.00 1,569.29	2.03%
US Treasury Note 2.625% Dtd 02/28/2018 Due 02/28/2023	50,000.000	49,856.00 50,357.63	1,312.00 445.95	2.63%
US Treasury Note 2.625% Dtd 06/30/2018 Due 06/30/2023	50,000.000	49,523.00 50,312.37	1,312.00 3.62	2.65%
US Treasury Note 2.375% Dtd 04/30/2019 Due 04/30/2026	180,000.000	170,073.00 171,091.41	4,275.00 732.18	2.51%
US Treasury Note 1.75% Dtd 06/30/2019 Due 06/30/2024	20,000.000	19,168.80 19,114.91	350.00 0.96	1.83%
Total Fixed Income		\$ 5,987,565.40 \$ 6,129,295.61	120,380.00 27,185.22	2.01%
Cash				
Principal Cash		0.00 0.00	0.00	0.00%
Income Cash		0.00 0.00	0.00	0.00%
Total Cash		\$ 0.00 \$ 0.00	0.00 0.00	0.00%



WBSD - RECYCLED WATER CASH FLOW

Account Number:
 Statement Period:

61-J260-01-0
 10/01/22 - 12/31/22

Asset Position As of 12/31/22

Asset Description	Units	Market Value Cost	Est. Annual Income Accruals	Current Yield
Total Market Value		\$ 6,016,577.91	121,584.00	2.02%
		\$ 6,158,308.12	27,577.99	
Total Market Value Plus Accruals		\$ 6,044,155.90		

Income Activity

	Date	Income Cash	Principal Cash
Interest Income			
Bank of The West Advantage Acct			
Int To 09/30/22	10/03/22		29.88
Int To 10/31/22	11/01/22		172.05
Int To 11/30/22	12/01/22		106.38
BB&T Corp Sr Medium Term Nts Fr 3.70% Dtd 06/05/2018 Due 06/05/2025 Callable			
Int To 12/05/22 on 15,000	12/05/22		277.50
Federal Farm Cr Bks Cons Systemwide Bds 0.71% Dtd 04/21/2021 Due 04/21/2025 Callable			
Int To 10/21/22 on 20,000	10/21/22		71.00
Kla Tencor Corp Sr Glbl Nt 4.65% Dtd 11/06/2014 Due 11/01/2024 Callable			
Int To 11/01/22 on 20,000	11/01/22		465.00
New York N Y GO Bds Subser Taxable 4.669% Dtd 10/15/2009 Due 10/01/2022 Callable			
Int To 10/01/22 on 35,000	10/03/22		817.07
New York N Y GO Bds 2010 D Taxable 5.199% Dtd 12/17/2009 Due 12/01/2022 Callable			
Int To 12/01/22 on 60,000	12/01/22		1,559.70
US Treasury Note 0.125% Dtd 12/15/2020 Due 12/15/2023			
Int To 12/15/22 on 20,000	12/15/22		12.50
US Treasury Note 1.625% Dtd 10/31/2016 Due 10/31/2023			
Int To 10/31/22 on 50,000	10/31/22		406.25



WBSD - RECYCLED WATER CASH FLOW

Account Number:
 Statement Period:

61-J260-01-0
 10/01/22 - 12/31/22

Income Activity			
	Date	Income Cash	Principal Cash
US Treasury Note 2.50% Dtd 05/15/2014 Due 05/15/2024 Int To 11/15/22 on 1,600,000	11/15/22		20,000.00
US Treasury Note 2.00% Dtd 06/30/2017 Due 06/30/2024 Int To 12/31/22 on 20,000	12/30/22		200.00
US Treasury Note 2.75% Dtd 06/30/2018 Due 06/30/2025 Int To 12/31/22 on 40,000	12/30/22		550.00
US Treasury Note 1.75% Dtd 12/31/2019 Due 12/31/2026 Int To 12/31/22 on 150,000	12/30/22		1,312.50
US Treasury Note 2.625% Dtd 06/30/2018 Due 06/30/2023 Int To 12/31/22 on 50,000	12/30/22		656.25
US Treasury Note 1.75% Dtd 06/30/2019 Due 06/30/2024 Int To 12/31/22 on 20,000	12/30/22		175.00
Total Interest Income		\$ 0.00	\$ 26,811.08
Purchased Income			
US Treasury Note 0.50% Dtd 02/28/2021 Due 02/28/2026 Accrued Int To 12/27/22 Paid on Purchase of 30,000	12/27/22		-48.89
US Treasury Note 2.75% Dtd 06/30/2018 Due 06/30/2025 Accrued Int To 11/08/22 Paid on Purchase of 40,000	11/08/22		-391.57
US Treasury Note 1.75% Dtd 12/31/2019 Due 12/31/2026 Accrued Int To 12/23/22 Paid on Purchase of 150,000	12/23/22		-1,255.44
US Treasury Note 1.875% Dtd 07/31/2019 Due 07/31/2026 Accrued Int To 12/23/22 Paid on Purchase of 200,000	12/23/22		-1,477.58
US Treasury Note 2.375% Dtd 04/30/2019 Due 04/30/2026 Accrued Int To 12/23/22 Paid on Purchase of 180,000	12/23/22		-625.90



WBSD - RECYCLED WATER CASH FLOW

Account Number:
 Statement Period:

61-J260-01-0
 10/01/22 - 12/31/22

Income Activity			
	Date	Income Cash	Principal Cash
US Treasury Note 1.75% Dtd 06/30/2019 Due 06/30/2024 Accrued Int To 11/08/22 Paid on Purchase of 20,000	11/08/22		-124.59
Total Purchased Income		\$ 0.00	\$ -3,923.97
Total Income		\$ 0.00	\$ 22,887.11

Additions			
	Date	Income Cash	Principal Cash
Miscellaneous Additions			
Addition To Account ACH Transfer From Botw Ckg Ending In 6049 Per Client Instructions: 12/15/22	12/20/22		456,100.00
Total Miscellaneous Additions		\$ 0.00	\$ 456,100.00
Total Additions		\$ 0.00	\$ 456,100.00

Disbursement Activity			
	Date	Income Cash	Principal Cash
Fees/Expenses			
Monthly Fee To 09/30/22	10/14/22		-796.93
Monthly Fee To 10/31/22	11/15/22		-795.26
Monthly Fee To 11/30/22	12/15/22		-798.99
Total Fees/Expenses		\$ 0.00	\$ -2,391.18
Total Disbursements		\$ 0.00	\$ -2,391.18



WBSD - RECYCLED WATER CASH FLOW

Account Number:
 Statement Period:

61-J260-01-0
 10/01/22 - 12/31/22

Purchase Activity			
	Date	Income Cash	Principal Cash
Bank of The West Advantage Acct Purchases (10) 10/01/22 To 12/31/22	12/31/22		-577,911.08
US Treasury Note 0.50% Dtd 02/28/2021 Due 02/28/2026 Purchased 30000 12/23/22 From Wells Fargo Securities, LLC @ 89.511718	12/27/22		-26,853.51
US Treasury Note 2.75% Dtd 06/30/2018 Due 06/30/2025 Purchased 40000 11/07/22 From Wells Fargo Securities, LLC @ 95.363281	11/08/22		-38,145.32
US Treasury Note 1.75% Dtd 12/31/2019 Due 12/31/2026 Purchased 150000 12/22/22 From BNY Mellon/Toronto Dominion Sec @ 92.214843	12/23/22		-138,322.27
US Treasury Note 1.875% Dtd 07/31/2019 Due 07/31/2026 Purchased 200000 12/22/22 From Morgan Stanley & Co @ 93.132812	12/23/22		-186,265.63
US Treasury Note 2.375% Dtd 04/30/2019 Due 04/30/2026 Purchased 180000 12/22/22 From Wells Fargo Securities, LLC @ 95.050781	12/23/22		-171,091.41
US Treasury Note 1.75% Dtd 06/30/2019 Due 06/30/2024 Purchased 20000 11/07/22 From Wells Fargo Securities, LLC @ 95.148437	11/08/22		-19,029.69
Total Purchases		\$ 0.00	\$ -1,157,618.91



WBSD - RECYCLED WATER CASH FLOW

Account Number:
Statement Period:

61-J260-01-0
10/01/22 - 12/31/22

Sale Activity			
	Date	Proceeds	Realized Gain/Loss
Bank of The West Advantage Acct Sales (6) 10/01/22 To 12/31/22	12/31/22	586,022.98	
New York N Y GO Bds Subser Taxable 4.669% Dtd 10/15/2009 Due 10/01/2022 Callable Recd Proceeds on Maturity of 35,000 Par Value	10/03/22	35,000.00	
New York N Y GO Bds 2010 D Taxable 5.199% Dtd 12/17/2009 Due 12/01/2022 Callable Recd Proceeds on Maturity of 60,000 Par Value	12/01/22	60,000.00	
Total Sales		\$ 681,022.98	\$ 0.00

Non-Cash Activity		
	Date	Cost
BB&T Corp Sr Medium Term Nts Fr 3.70% Dtd 06/05/2018 Due 06/05/2025 Callable Amortization of Premium	12/05/22	-208.80
Kla Tencor Corp Sr Glbl Nt 4.65% Dtd 11/06/2014 Due 11/01/2024 Callable Amortization of Premium	11/01/22	-342.00
New York N Y GO Bds Subser Taxable 4.669% Dtd 10/15/2009 Due 10/01/2022 Callable Amortization of Premium	10/03/22	-462.35
New York N Y GO Bds 2010 D Taxable 5.199% Dtd 12/17/2009 Due 12/01/2022 Callable Amortization of Premium	12/01/22	-170.90
	12/01/22	-854.50
US Treasury Note 0.125% Dtd 12/15/2020 Due 12/15/2023 Accretion of Discount	12/15/22	208.36
US Treasury Note 1.625% Dtd 10/31/2016 Due 10/31/2023 Amortization of Premium	10/31/22	-24.19



WBSD - RECYCLED WATER CASH FLOW

Account Number:
Statement Period:

61-J260-01-0
10/01/22 - 12/31/22

Non-Cash Activity		
	Date	Cost
US Treasury Note 2.50% Dtd 05/15/2014 Due 05/15/2024 Accretion of Discount	11/15/22	826.74
US Treasury Note 2.00% Dtd 06/30/2017 Due 06/30/2024 Accretion of Discount	12/30/22	99.81
US Treasury Note 2.75% Dtd 06/30/2018 Due 06/30/2025 Accretion of Discount	12/30/22	101.30
US Treasury Note 1.75% Dtd 12/31/2019 Due 12/31/2026 Accretion of Discount	12/30/22	56.49
US Treasury Note 2.625% Dtd 06/30/2018 Due 06/30/2023 Amortization of Premium	12/30/22	-310.24
US Treasury Note 1.75% Dtd 06/30/2019 Due 06/30/2024 Accretion of Discount	12/30/22	85.22
Total Non-Cash Transactions		\$ -995.06

SECURITY PRICES CONTAINED IN THIS STATEMENT ARE OBTAINED FROM THE MOST RELIABLE SOURCES AVAILABLE BUT ARE NOT GUARANTEED BY BANK OF THE WEST. QUOTED PRICES MAY NOT EQUAL ACTUAL PRICES BECAUSE OF SECURITY SIZE, MARKET PRICE, TERM AND DEMAND.



Electronic Funds Transfers

Preauthorized Transfers:

You may request an electronic fund transfer (EFT), such as an ACH transfer from or deposit to your account, by contacting your account Administrator. You may also preauthorize periodic EFTs by contacting your account Administrator. If you would like to know whether a preauthorized EFT has occurred, please contact your account Administrator at the phone number listed on the first page of your statement. TTY 1-866-936-2689, Monday - Friday, 8 a.m. - 4:30 p.m. Central Time.

Error Resolution Notice:

If you think a statement or receipt is wrong or if you need more information about an EFT listed on a statement or receipt, telephone your account Administrator at the phone number listed on the first page of your statement, TTY 1-866-936-2689, Monday - Friday, 8 a.m. - 4:30 p.m. Central Time, write to us at Bank of the West, GIFS Operations, 12000 North Washington Street, Suite, 300, Thornton, CO 80241 or e-mail us at WMGGIFSOperations@bankofthewest.com as soon as possible. We must hear from you no later than 60 days after we sent the FIRST statement on which the problem or error appeared.

1. Tell us your name and account number (if any).
2. Tell us the dollar amount of the suspected error.
3. Describe the error or the transfer you are unsure about, and explain as clearly as you can why you believe it is an error or why you need more information.

If you contact us verbally, we may require that you send us your complaint or question in writing within 10 business days. We will investigate your complaint and will correct any error promptly. If we take more than 10 business days to do this, we will credit your account for the amount you think is in error, so that you will have the use of the money during the time it takes us to complete our investigation.



WEST BAY SANITARY DISTRICT AGENDA ITEM 7

To: *Board of Directors*

From: *Sergio Ramirez, General Manager*

Subject: *Consider Establishing February 8, 2023 as the Date of Public Hearing to Consider a Board Member Compensation General Regulation Amending the Code of General Regulations*

Background

Per Government Code the compensation that may be paid to a Board Member for each day's attendance at meetings may be increased annually by five percent. Since the last increase was in February 2022, the Board could elect to increase 5% effective February 2023. This means the Board may increase its compensation from \$250.00 per meeting to \$262.50 per meeting.

Analysis

The financial health of the District is such that a small increase in Director's fee expenses would have negligible effect on the budget and increased Director Fees may enhance the Board's efforts to find successor Board members.

Should the Board determine to approve this increase, a Public Hearing will be scheduled for February 8, 2023, at which time the Board may adopt the attached Regulation.

Fiscal Impact

A 5% increase in Board of Director fees would have an immaterial impact on the budget. Generally, in 2022 the Board of Directors attended two meetings per month collecting approximately \$500.00 each per month in fees. The 5 % increase in 2023 would allow Board of Directors to collect \$525.00 per month on average.

Recommendation

The General Manager recommends the Board establishing February 8, 2023 as the date of public hearing to consider General Regulation amending the Code of General Regulations for Board Member Compensation.

THIS PAGE LEFT INTENTIONALLY BLANK



**WEST BAY SANITARY DISTRICT
AGENDA ITEM 8**

To: Board of Directors

From: Sergio Ramirez, General Manager

Subject: Discussion and Direction on the West Bay and Sharon Heights Recycled Water Facility

A discussion will be held on the Sharon Heights Recycled Water Facility and other events related to the recycled water plant. The Board will have opportunity to provide direction to staff and legal counsel.

Recycled Water Facility Production Data:

2020	Treated	Delivered
August	8.8MG	8.2MG
September	8.2MG	5.1MG
October	7.4MG	4.5MG
November	5MG	1.4MG
December	4.7MG	.55MG
2021	Treated	Delivered
January	4.8MG	.23MG
February	4.4MG	.13MG
March	5.9MG	1.8MG
April	8.5MG	7.6MG
May	9.3.MG	8.2MG
June	9.8MG	8.7MG
July	9.5MG	9.1MG
August	9.4MG	9.0MG
September	9.1MG	6.9MG*
October	7.6MG	2.6MG**
November	5.2MG	0
December	4.7MG	0

Report to the District Board for the Regular Meeting of January 25, 2023

2022	Treated	Delivered
January	4.4MG	97,000 gallons
February	4.4MG	1.5MG
March	6.6MG	3.5MG
April	7.6MG	3.8MG
May	9.2MG	7.4MG
June	9.8MG	8.7MG
July	9.6MG	8.1MG
August	9.2MG	8.1MG
September	8.6MG	6.7MG
October	7.9MG	4.6MG
November	5.9MG	310,000 gallons
December	5.4MG	154,690 gallons

- * Sharon Heights substantially tapered off their water usage for September which is the reason for the large discrepancy between treated and delivered.
- ** Treatment was reduced in the second half of the month. Rain in late October and an irrigation equipment malfunctions caused water delivery to decrease.

The following is a disclosure statement required for any document, written report or brochure prepared in whole or in part pursuant to the Finance Agreement with the State Water Resources Control Board for the West Bay Sanitary District Recycled Water Project - Sharon Heights: Funding for this project has been provided in full or in part through an agreement with the State Water Resources Control Board. California's Clean Water State Revolving Fund is capitalized through a variety of funding sources, including grants from the United States Environmental Protection Agency and state bond proceeds. The contents of this document do not necessarily reflect the views and policies of the foregoing, nor does mention of trade names or commercial products constitute endorsement or recommendation for use.



**WEST BAY SANITARY DISTRICT
AGENDA ITEM 9**

To:*Board of Directors*

From:*Sergio Ramirez, General Manager*

Subject:*Discussion and Direction on the Bayfront Recycled Water Project
and Status Update*

A discussion will be held on the District's Bayfront Recycled Water Projects and other events related to the recycled water projects including financing, environmental review, design/build issues and grant applications.

The Board will have opportunity to provide direction to staff and general counsel.

THIS PAGE LEFT INTENTIONALLY BLANK



**WEST BAY SANITARY DISTRICT
AGENDA ITEM 10**

To: Board of Directors

From: Sergio Ramirez, General Manager

Subject: Report and Discussion on South Bayside Waste Management Authority (SBWMA)

The District's representative to South Bayside Waste Management Authority (SBWMA), President Fran Dehn, will report on any pertinent items regarding SBWMA business.

THIS PAGE LEFT INTENTIONALLY BLANK



**WEST BAY SANITARY DISTRICT
AGENDA ITEM 11**

To: *Board of Directors*

From: *Sergio Ramirez, General Manager*

**Subject: *Report and Discussion on Silicon Valley Clean Water (SVCW)
Plant***

The District's representative to Silicon Valley Clean Water (SVCW), Commissioner George Otte, will report on pertinent items regarding SVCW Operations, CIP and Finance.

THIS PAGE LEFT INTENTIONALLY BLANK