

1902 - Serving Our Community for over 120 Years - 2023
WEST BAY SANITARY DISTRICT
AGENDA OF BUSINESS
REGULAR MEETING OF THE DISTRICT BOARD
WEDNESDAY, APRIL 12, 2023 AT 7:00 P.M.
RONALD W. SHEPHERD ADMINISTRATION BUILDING,
500 LAUREL STREET, MENLO PARK, CALIFORNIA 94025

Board Members

Fran Dehn, President
David Walker, Secretary
Roy Thiele-Sardiña, Treasurer
Edward P. Moritz, Member
George Otte, Member

General Manager

Sergio Ramirez

District General Counsel

Anthony Condotti, Esq.

AGENDA OF BUSINESS

To participate by telephone or Zoom meeting, public comments can be made by joining Zoom meeting at:

<https://us06web.zoom.us/j/86417041289?pwd=NWF5ZXFSTHV6anR6VVliaHlIZm5NUT09>

Meeting ID: 864 1704 1289 Passcode: 545618

NOTE: The Board may take action on any agendized item unless specifically designated a “discussion” item or a “report.”

1. Call to Order and Roll Call
2. Communications from the Public
3. Consent Calendar

Matters listed under this item are considered routine and will be enacted by one motion. The motion, seconds, and vote are applicable to any included resolutions and recorded accordingly. There will be no separate discussion of these items unless specifically requested by a member of the Board.

 - A. Approval of Minutes for Regular Meeting March 22, 2023 Pg. 3A-1
 - B. Approval of the Financial Activity Report Authorizing Payment of Certain Bills and Salaries and Consideration of Other Financial Matters thru March 31, 2023 Pg. 3B-1
 - C. WBSD Operations and Maintenance Report – March 2023 Pg. 3C-1
 - D. Town of Los Altos Hills Operations and Maintenance Report for Work Performed by WBSD – March 2023 Pg. 3D-1
 - E. Town of Woodside Operations and Maintenance Report for Work Performed by WBSD – March 2023 Pg. 3E-1
 - F. Bank of the West Monthly Investment Portfolio Statements
4. General Manager’s Report Pg. 4-1

5. Presentation by CitizenM Hotel located at 300 Constitution Drive, Menlo Park Pg. 5-1
6. Consider Approving Closing of Andrighetto Reimbursement Agreement Pg. 6-1
7. Consider Approving Closing of Boyce Reimbursement Agreement Pg. 7-1
8. Discussion and Direction on Sharon Heights Recycled Water Plant Pg. 8-1
9. Discussion and Direction on Bayfront Recycled Water Project and Status Update Pg. 9-1
10. Report and Discussion on South Bayside Waste Management Authority (SBWMA) Pg. 10-1
11. Report and Discussion on Silicon Valley Clean Water (SVCW) Plant Pg. 11-1
12. Closed Session

A. CONFERENCE WITH REAL PROPERTY NEGOTIATOR

(Cal. Govt. Code § 54956.8)

Property: 1101 Altschul Avenue

Agency negotiator: General Manager/General Counsel

Negotiating parties: District and Los Lomitas Elementary School District

Under negotiation: Price/terms of payment for Avy Altschul Pump Station Easement

13. Consider Approving a Deed of Easement between Las Lomitas Elementary School District and West Bay Sanitary District for the Avy Altschul Pump Station Pg. 13-1
14. Comments or Reports from Members of the District Board and Consider Items to be Placed on Future Agenda
15. Adjournment

The West Bay Sanitary District does not discriminate against persons with disabilities. Upon request, the agenda and agenda packet can be provided in a format to accommodate special needs. If you require a copy of the agenda or related materials in an alternative format to accommodate a disability, or if you wish to attend this public meeting and will require special assistance or other special equipment, please call the District at (650) 321-0384 at least five days in advance and we will make every reasonable attempt to provide such an accommodation.



1902 - *Serving Our Community for over 115 Years* - 2023

WEST BAY SANITARY DISTRICT
MINUTES OF THE REGULAR MEETING OF THE DISTRICT BOARD
WEDNESDAY, MARCH 22, 2023 AT 7:00 P.M.

1. **Call to Order**

President Dehn called the meeting to order at 7:00 PM

Roll Call

BOARD MEMBERS PRESENT: President Dehn, Secretary Walker, Treasurer Thiele-Sardiña, Director Moritz, Director Otte

BOARD MEMBERS ABSENT: None

STAFF MEMBERS PRESENT: Ramirez, Condotti by Zoom

Others Present: Rich Laretta – Fryer & Laretta

2. **Communications from the Public:** None.

3. **Public Hearing: Consider Waiving Collection of Future Supplemental Connection Charges for the Blue Oaks Subdivision Reimbursement Agreement**

Motion to Open by: Moritz 2nd by: Thiele-Sardiña Vote: AYE: 5 NAY: 0 Abstain: 0

Discussion/Comments: General Manager Ramirez reported the agreement was entered into in 2002 with Portola Valley Blue Oaks Ltd. Partnership in which the construction costs were collected through supplemental connection fees and then reimbursed to prior connectors. He continued to report the remaining balance of the agreement became too small to continue to collect on since the supplemental connection fee was \$5000 and reimbursed to over 100 connectors. Recent reimbursees received checks for approximately \$27.39. Therefor he recommended the Board of Directors waive collecting any further on this agreement. There was a motion to approve waiving further collection on the agreement by Director Moritz, a second by Secretary Walker and vote to approve 5 Aye, 0 Nay.

Motion to Close by: Otte 2nd by: Moritz Vote: AYE: 5 NAY: 0 Abstain: 0

Motion to Approve by: Moritz 2nd by: Walker Vote: AYE: NAY: Abstain:

4. **Consent Calendar**

CONSIDERATION OF ITEM(S) REMOVED FROM THE CONSENT CALENDAR

Discussion/Comments: None

- A. Approval of Minutes for Regular Meeting March 8, 2023
- B. Accepting Deed of Easement Pursuant to Class 3 Sewer Permit No. 1605 for the Construction of Wastewater Facilities for 30 Cheyenne Point, Portola Valley, California
- C. Bank of the West Monthly Investment Portfolio Statements

Motion to Approve by: Thiele-Sardiña 2nd by: Otte Vote: AYE: 5 NAY: 0 Abstain: 0

5. General Manager's Report

Discussion/Comments: General Manager Ramirez reported staff has updated the District Code of General Regulations and General Counsel is currently reviewing it before Board consideration. He reported staff are preparing an invoice for Silicon Valley Clean Water for use of the emergency pond at the Flow Equalization Facility (FEF.) He also reported the City of East Palo Alto is conducting a request for qualifications for operation and maintenance services. He reported the Construction Inspector's vehicle was totaled when a tree fell on it during recent storm events. General Manager Ramirez continued to report the Clerical Assistant's 18-month long project is complete and her last day will be April 4th. He reported there is still a considerable amount of material to scan in storage at the FEF. Board consensus was to continue the Clerical Assistant's employment for another year to work on the remaining scanning. The next regular Board meetings will be April 12th and April 26th. The Budget Workshop will be held on May 3rd. The complete General Manager's written report is in the March 22nd, 2023, agenda packet.

6. Consider Authorizing the General Manager to Issue the Call for Bids for the Avy-Altschul Pump Station Project

Motion to Approve by: Otte 2nd by: Walker Vote: AYE: 5 NAY: 0 Abstain: 0

Discussion/Comments: None.

7. Consider Authorizing the General Manager to Issue the Call for Bids for the Flow Equalization and Resource Recovery Facility Levee Improvement Project

Motion to Approve by: Moritz 2nd by: Otte Vote: AYE: 5 NAY: 0 Abstain: 0

Discussion/Comments: General Manager Ramirez reported the project's projected cost is \$10,700,000.00. A National Fish and Wildlife Foundation grant will cover \$3,626,020 in construction costs and the remaining construction costs will come from the Construction in Progress Budget. Board consensus was to approve the call for bids with the understanding staff will consider a performance payment and return to the Board with addendums for approval.

8. Consider Authorizing the General Manager to Enter Into an Agreement for On-Call Construction Consultation Support with Freyer & Laureta, Inc. (F&L) for the Flow Equalization and Resource Recovery Facility Levee Improvement Project

Motion to Approve by: Walker 2nd by: Moritz Vote: AYE: 5 NAY: 0 Abstain: 0

Discussion/Comments: None.

9. Report and Discussion on Sharon Heights Recycled Water Plant

Discussion/Comments: General Manager Ramirez reported negotiations are underway with the Los Lomitas School District regarding an easement on their property for the Avy/Altschul Pump Station. The project will be funded by a \$950,000 SRF loan which includes 3A-2

approximately \$333,000 in a grant. An agreement to pay back the SRF is being prepared by the District's General Counsel with Sharon Heights Golf Club. Construction is expected to begin June 15th when school is out of session.

10. Discussion and Direction on Bayfront Recycled Water Project and Status Update

Discussion/Comments: General Manager Ramirez reported SCWA will begin to monitor the habitat and wildlife at the site location. He also reported the project management agreement has been received from Meta/Signature Group in the amount of \$951,000 of which Meta will pay \$409,000. He stated the District is working with the City of Menlo Park for an encroachment permit for the levee.

11. Report & Discussion on South Bayside Waste Management Authority (SBWMA)

Discussion/Comments: None.

12. Report, Discussion & Direction on Silicon Valley Clean Water (SVCW) and Discussion on SVCW CIP Program and Financing

Discussion/Comments: Director Otte reported on the approval of the design/build process for the Foods Waste Project. He also reported the SVCW General Manager has declared an emergency to repair a leak on the 54-inch forcemain leading to the plant.

13. Closed Session

Entered closed session at 8:56 p.m. Left closed session at 9:08 p.m.

- A. CONFERENCE WITH LEGAL COUNSEL – EXISTING LITIGATION
(Cal. Govt. Code §54956.9(d))
Name of Case: *1740 Oak Avenue, LP v. West Bay Sanitary District, et al.* –
SMCSC Case No. 18CIV02183

Reportable action: None.

14. Comments or Reports from Members of the District Board and Consider Items to be Placed on Future Agenda

Discussion/Comments: None.

15. Adjournment Time: The meeting was adjourned at 9:09 PM

THIS PAGE LEFT INTENTIONALLY BLANK



WEST BAY SANITARY DISTRICT
Financial Activity Report
March 2023

Date: *April 12, 2023*

To: *Board of Directors*

From: *Annette Bergeron, Personnel & Accounting Specialist*
Debra Fisher, Finance Manager

Subject: *Approve Monthly Financial Activity Report*

Financial Activity for the month of March 2023.

Receipt Summary:

Commercial Deposits	118,751.65
Deposits in Transit/(Prior Period)	0.00
Credit Cards	7,002.75
Franchise Fees	9,721.18
San Mateo County [Tax Roll]	1,527,008.18
Other Receipts	107,050.43
Transfers	2,000,000.00
Total Receipts	<u>3,769,534.19</u>

Withdrawal Summary

Total Checks	716,536.28
Total Corp Cards	21,601.93
Total Bank Wires/ACHs	1,768,689.53
External Withdrawals	2,506,827.74
Total Internal Bank Transfers	75,000.00
Total Withdrawals	<u>2,581,827.74</u>

Fund Expenditure Summary by Budget Category

100	Operations	1,032,984.69
200	Capital	176,901.14
300	Solid Waste	0.00
500	Recycled Water	780,384.91
800	Silicon Valley Clean Water	591,557.00
Expenditures by Fund		<u>2,581,827.74</u>

Presented to West Bay Sanitary District Board of Directors for review and approval.

President _____

Secretary _____

**West Bay Sanitary District
Receipts
March 2023**

RECEIPT NUMBER	RECEIPT DATE	DESCRIPTION	AMOUNT
462917	3/1/2023	Kitaura Construction: Permit: 124 Blackburn, Permit	290.00
462918	3/2/2023	Roto Rooter: 2631 Alpine Rd, MP, Permit	290.00
462919	3/1/2023	City of Menlo Park: , Mandatory Wastewater Discharge Complia	33,743.54
462920	3/3/2023	Lance & Chelsea Thompson: 177 Los Trancos, PV, SSC FY2022-23	1,280.00
462921	3/3/2023	WBSD: Transfer LAIF to BofW Checking	2,000,000.00
462922	3/7/2023	OHC of California: Lab Fee Overpayment - Fariborz H.	30.00
462923	3/7/2023	Town of Los Altos Hills: MSA 1/2023	48,098.73
462924	3/7/2023	AKD Homes: 951 Peninsula Way, MP, ADU & Permit	8,467.60
462925	3/8/2023	Jane E. Aaron: 10 Garland Pl., MP, Permit	355.00
462926	3/9/2023	Levent Niazi: 847 Woodland Ave, MP, Permit	290.00
462927	3/8/2023	SHGCC: O&M 3/2023 & Avy/Solar Project Reim	49,433.19
462928	3/13/2023	Bayshore Plumbers: 2150 Ashton Ave, MP, Permit	290.00
462929	3/13/2023	Jane E. Aaron: 10 Garland Place, MP, Permit	35.00
462930	3/10/2023	Recology: SW Franchise Fee 2/2023	9,721.18
462931	3/14/2023	Bayshore Plumbers: 24 Watkins Ave, Ath, Permit	290.00
462932	3/15/2023	Michels Pacific Energy: Emergency Line Repair	22,339.20
462933	3/15/2023	Eli Jackson: Multiple Locations, CCTV C3 Permit	2,585.00
462934	3/15/2023	Pro Roto: 915 Marsh Rd, MP, Permit	355.00
462935	3/15/2023	Thomas James Homes: 440 University Dr, MP, Permit	290.00
462936	3/17/2023	Bayshore Plumbers: 136 Hedge Rd, MP, Permit	290.00
462937	3/20/2023	Bankcard: Refund \$2,000 Rivian Deposits on BofW Bankcard	2,000.00
462938	3/22/2023	Roto-Rooter: 2615 Alpine Rd, MP, Permit	290.00
462939	3/22/2023	Roto Rooter: 1351 Carlton Ave, MP, Permit	290.00
462940	3/23/2023	EJ Plumbing: 631 Arbor Rd, MP, Permit	355.00
462941	3/23/2023	Novo Construction: 460 Cervantes Rd, PV, ADU, Permits & RA	12,005.92
462942	3/27/2023	SHGCC: Sand Hill Road Force Main Repair 2/9/23-2/10/23	21,873.70
462943	3/28/2023	Bayshore Plumbers: 301 Arbor Rd, MP, Permit	290.00
462944	3/29/2023	Benchmark Builders: 54 Reservoir Road, Ath, ADU & Permit	5,885.20
462945	3/30/2023	SMC: SSC Tax Remittance 2nd Period 5% Advance FY 2022-23	1,527,008.18
462946	3/30/2023	Veronica Gonzalez: 990 La Mesa Dr, PV, Permit	312.75
462947	3/30/2023	Citizenm Asset Mgmt: 300 Constitution, Entitlement Transfer Fee	20,290.00
462948	3/31/2023	Utopia Construction: 18 Patterson Ave, MP, Permit	170.00
462949	3/22/2023	Bayshore Plumbers: 127 Laurel Ave, MP, Permit	290.00
Total Receipts			<u>\$3,769,534.19</u>

**West Bay Sanitary District
Financial Activity Report
Withdrawals
March 2023**

Check	Date	Payee	Purpose	Amount
70107	3/3/2023	Dave Russell A Lojera	Payroll 02/18-03/03/2023 Final Check	6,453.64
70108	3/2/2023	AAA Rentals	Mini Excavator Rental 2/2023	1,151.50
70109	3/2/2023	Ace Fire Equipment & Service	Fire Extinguisher Service 1/2023	2,342.38
70110	3/2/2023	ReadyRefresh By Nestle	Water Delivery 1/11/23-2/10/23	363.26
70111	3/2/2023	Atchison, Barisone & Condotti	Legal Services 1/2023	8,419.70
70112	3/2/2023	Battery Junction Wholesale	Rayovac Alkaline 6V Lantern Battery (52) 2/2023	860.86
70113	3/2/2023	Bay Alarm	Alarm Monitoring Service 3/1/23-5/31/23	796.50
70114	3/2/2023	Bay Area Air Quality Mgmt Dist	Annual Permit Renewals FY 23/24	916.00
70115	3/2/2023	Bay Area Paving Co.	Sand Hill Rd Asphalt Paving Force Main Leak Repair 2/2023	5,900.00
70116	3/2/2023	CWEA	2023 Annual Conference Registration A.Ambriz 4/2023	862.00
70117	3/2/2023	California Water Service	Water Services - Jan-Feb 2023	137.81
70118	3/2/2023	Cintas	Uniform Service 2/22/23	1,033.97
70119	3/2/2023	Comcast	Internet - Sand Hill Rd 2/18/23-3/17/23	272.29
70120	3/2/2023	Grainger	PPE, Misc.Parts & Supplies, Small Tools & Equipment 2/2023	3,736.21
70121	3/2/2023	Kimball Midwest	Tools 2/2023	1,761.32
70122	3/2/2023	Sione Lolohea	Reim: CWEA Membership & OWP Class S.Lolohea	357.00
70123	3/2/2023	City Of Menlo Park - Water	Water Service - Laurel St 1/6/23-2/3/23	494.39
70124	3/2/2023	Pacific Gas & Electric	Electric Service - Jan-Feb 2023	12,737.56
70125	3/2/2023	Preferred Alliance	DOT Testing Admin Fees 1/2023	238.68
70126	3/2/2023	Principal Life Insurance	Dental, Vision, Life, AD&D, Disability Ins 3/2023	6,858.51
70127	3/2/2023	Teamsters Local No. 350	Union Dues 3/2023	945.00
70128	3/2/2023	Western Truck Fabrication, Inc	Unit 209 Compressor Pulley Repair 2/2023	1,596.60
70129	3/2/2023	Woodard & Curran	Woodside Reclaimed Water Facility Plan 2/2023	12,510.00
70130	3/8/2023	Tyler Garratt	Reim Agreement: Garratt Resolution #1442 Reissue SII Conn5-7	10,345.71
70131	3/8/2023	Elizabeth Hayden	Reim Agreement: Garratt Resolution #1442 Reissue SII Conn5-7	10,345.71
70132	3/8/2023	David Douglas	Reim Agreement: Blue Oaks Resolution #1487(02) Conn#108&109	27.39
70133	3/8/2023	Haas & Hayne	Reim Agreement: Blue Oaks Resolution #1487(02) Conn#108&109	1,040.82
70134	3/8/2023	Kent Ryhorchuk & Cathy Brewer	Reim Agreement: Blue Oaks #108&109 & Sewer4LosTrancos #69&70	1,483.53
70135	3/8/2023	Yanting Zhang	Reim Agreement: Blue Oaks #108&109 & Sewer4LosTrancos #69&70	1,483.53
70136	3/8/2023	Lynne Penek - Holden	Reim Agreement: Blue Oaks #108&109 & Sewer4LosTrancos #69&70	1,483.53
70137	3/8/2023	Charles & Toni Markley	Reim Agreement: Blue Oaks #108&109 & Sewer4LosTrancos #69&70	2,967.06
70138	3/8/2023	David H. Mcmurry	Reim Agreement: Blue Oaks #108&109 & Sewer4LosTrancos #69&70	1,483.53
70139	3/8/2023	Erin & Julie Whalan	Reim Agreement: Blue Oaks #108&109 & Sewer4LosTrancos #69&70	1,483.53
70140	3/8/2023	John Nightingale	Reim Agreement: Blue Oaks #108&109 & Sewer4LosTrancos #69&70	1,483.53
70141	3/8/2023	Frazier Miller	Reim Agreement: Blue Oaks #108&109 & Sewer4LosTrancos #69&70	1,483.53
70142	3/8/2023	Thomas V. & Nusrat T. Uridel	Reim Agreement: Blue Oaks #108&109 & Sewer4LosTrancos #69&70	1,483.53
70143	3/8/2023	Heather Kirkby	Reim Agreement: Blue Oaks #108&109 & Sewer4LosTrancos #69&70	1,483.53
70144	3/8/2023	Victoria S. Sargent	Reim Agreement: Blue Oaks #108&109 & Sewer4LosTrancos #69&70	1,483.53
70145	3/8/2023	Lyn Louise Dearborn	Reim Agreement: Blue Oaks #108&109 & Sewer4LosTrancos #69&70	1,483.53
70146	3/8/2023	Robert J. & Nancy J. Neuer	Reim Agreement: Blue Oaks #108&109 & Sewer4LosTrancos #69&70	1,483.53
70147	3/8/2023	Stephen Daane & Sheryl Garrett	Reim Agreement: Blue Oaks #108&109 & Sewer4LosTrancos #69&70	1,483.53
70148	3/8/2023	Patricia Burns	Reim Agreement: Blue Oaks #108&109 & Sewer4LosTrancos #69&70	1,483.53
70149	3/8/2023	Scott & Jennifer Gamel	Reim Agreement: Blue Oaks #108&109 & Sewer4LosTrancos #69&70	1,483.53
70150	3/8/2023	Thomas W. Sisson	Reim Agreement: Blue Oaks #108&109 & Sewer4LosTrancos #69&70	1,483.53
70151	3/8/2023	The Jensen Family Trust	Reim Agreement: Blue Oaks #108&109 & Sewer4LosTrancos #69&70	1,483.53
70152	3/8/2023	Fumio Adachi	Reim Agreement: Blue Oaks #108&109 & Sewer4LosTrancos #69&70	1,483.53
70153	3/8/2023	Thomas Robert Clandinin	Reim Agreement: Blue Oaks #108&109 & Sewer4LosTrancos #69&70	1,483.53
70154	3/8/2023	Sean A. Curran	Reim Agreement: Blue Oaks #108&109 & Sewer4LosTrancos #69&70	1,483.53
70155	3/8/2023	David L. & Julie Duncan	Reim Agreement: Blue Oaks #108&109 & Sewer4LosTrancos #69&70	2,967.06
70156	3/8/2023	Lois Dubois	Reim Agreement: Blue Oaks #108&109 & Sewer4LosTrancos #69&70	1,483.53
70157	3/8/2023	Stephen Wheeler	Reim Agreement: Blue Oaks #108&109 & Sewer4LosTrancos #69&70	1,483.53
70158	3/8/2023	James H. Foster	Reim Agreement: Blue Oaks #108&109 & Sewer4LosTrancos #69&70	1,483.53
70159	3/8/2023	Palwasha & Zelikha Dost	Reim Agreement: Blue Oaks #108&109 & Sewer4LosTrancos #69&70	1,483.53
70160	3/8/2023	Ingrid B. Hardy	Reim Agreement: Blue Oaks #108&109 & Sewer4LosTrancos #69&70	1,483.53
70161	3/8/2023	William E. Nelson	Reim Agreement: Blue Oaks #108&109 & Sewer4LosTrancos #69&70	1,483.53
70162	3/8/2023	Claude Michael Beasley	Reim Agreement: Blue Oaks #108&109 & Sewer4LosTrancos #69&70	1,483.53
70163	3/8/2023	Stephen Dunne	Reim Agreement: Blue Oaks #108&109 & Sewer4LosTrancos #69&70	4,450.59
70164	3/8/2023	Nicolas Rochard & Leigh Birch	Reim Agreement: Blue Oaks #108&109 & Sewer4LosTrancos #69&70	1,483.53
70165	3/8/2023	Nancy & Robert Neuer	Reim Agreement: Blue Oaks #108&109 & Sewer4LosTrancos #69&70	1,483.53
70166	3/8/2023	Jerald Hall Jensen	Reim Agreement: Blue Oaks #108&109 & Sewer4LosTrancos #69&70	1,483.53
70167	3/8/2023	John Paul Huetter	Reim Agreement: Blue Oaks #108&109 & Sewer4LosTrancos #69&70	1,483.53
70168	3/8/2023	Joann Loulan	Reim Agreement: Blue Oaks #108&109 & Sewer4LosTrancos #69&70	1,483.53
70169	3/8/2023	Martin & Kristen Casado	Reim Agreement: Blue Oaks #108&109 & Sewer4LosTrancos #69&70	1,483.53
70170	3/8/2023	Gary Daniel Macgregor	Reim Agreement: Blue Oaks #108&109 & Sewer4LosTrancos #69&70	1,483.53
70171	3/8/2023	David Stagg	Reim Agreement: Blue Oaks #108&109 & Sewer4LosTrancos #69&70	1,483.53
70172	3/8/2023	Cindy Lee Russell	Reim Agreement: Blue Oaks #108&109 & Sewer4LosTrancos #69&70	1,483.53
70173	3/8/2023	Svend Agesen	Reim Agreement: Blue Oaks #108&109 & Sewer4LosTrancos #69&70	1,483.53
70174	3/8/2023	Mark Weiss	Reim Agreement: Blue Oaks #108&109 & Sewer4LosTrancos #69&70	1,483.53
70175	3/8/2023	Carol Kemper	Reim Agreement: Blue Oaks #108&109 & Sewer4LosTrancos #69&70	1,483.53
70176	3/8/2023	Grover T. Wickersham	Reim Agreement: Blue Oaks #108&109 & Sewer4LosTrancos #69&70	2,967.06
70177	3/8/2023	Armin Staprans	Reim Agreement: Blue Oaks #108&109 & Sewer4LosTrancos #69&70	1,483.53
70178	3/8/2023	Keith Reeves	Reim Agreement: Blue Oaks #108&109 & Sewer4LosTrancos #69&70	1,483.53
70179	3/8/2023	Ann Hardy	Reim Agreement: Blue Oaks #108&109 & Sewer4LosTrancos #69&70	1,483.53
70180	3/8/2023	Tracy & Peter Cowperthwaite	Reim Agreement: Blue Oaks #108&109 & Sewer4LosTrancos #69&70	1,483.53
70181	3/8/2023	Alexander M. Kostrikin	Reim Agreement: Blue Oaks #108&109 & Sewer4LosTrancos #69&70	1,483.53

West Bay Sanitary District

Financial Activity Report

Withdrawals

March 2023

70182	3/8/2023	Gregory G. Van Hauser	Reim Agreement: Blue Oaks #108&109 & Sewer4LosTrancos #69&70	1,483.53
70183	3/8/2023	Mary Kelley & Marc Levaggi	Reim Agreement: Blue Oaks #108&109 & Sewer4LosTrancos #69&70	1,483.53
70184	3/8/2023	David A. Lowin	Reim Agreement: Blue Oaks #108&109 & Sewer4LosTrancos #69&70	1,483.53
70185	3/8/2023	Sean Riley & Judy Riley	Reim Agreement: Blue Oaks #108&109 & Sewer4LosTrancos #69&70	1,483.53
70186	3/8/2023	Stig & Holly Nybo	Reim Agreement: Blue Oaks #108&109 & Sewer4LosTrancos #69&70	1,483.53
70187	3/8/2023	Kenneth D. Woods	Reim Agreement: Blue Oaks #108&109 & Sewer4LosTrancos #69&70	1,483.53
70188	3/8/2023	Mary Ann H. Furda	Reim Agreement: Blue Oaks #108&109 & Sewer4LosTrancos #69&70	1,483.53
70189	3/8/2023	Jancie L. Avilla	Reim Agreement: Blue Oaks #108&109 & Sewer4LosTrancos #69&70	1,483.53
70190	3/8/2023	Larry & Mary Anderson	Reim Agreement: Blue Oaks #108&109 & Sewer4LosTrancos #69&70	1,483.53
70191	3/8/2023	Ian Earnest	Reim Agreement: Blue Oaks #108&109 & Sewer4LosTrancos #69&70	2,967.06
70192	3/8/2023	Thomas & Jean Schellenberg	Reim Agreement: Blue Oaks #108&109 & Sewer4LosTrancos #69&70	1,483.53
70193	3/8/2023	CTJ	Reim Agreement: Blue Oaks #108&109 & Sewer4LosTrancos #69&70	1,483.53
70194	3/8/2023	Raivis Kampenuss	Reim Agreement: Blue Oaks #108&109 & Sewer4LosTrancos #69&70	1,483.53
70195	3/8/2023	Matt Gebhart	Reim Agreement: Blue Oaks #108&109 & Sewer4LosTrancos #69&70	1,483.53
70196	3/9/2023	3600 Haven Avenue, LP	Partial Refund of Sewer Service Charges 2019, 2020, 2021	38,939.80
70197	3/9/2023	A-A Lock & Alarm	Replacement Keys 2/2023	79.59
70198	3/9/2023	Zip's Aw Direct	Shop Brooms And Receiver For Unit 215 12/2022	826.23
70199	3/9/2023	Action Towing	Towing 3/2023	518.50
70200	3/9/2023	Matheson Tri-Gas	Tank Rentals 2/2023	60.60
70201	3/9/2023	Alpha Analytical Laboratories	Daily Coliform Samples - SHGCC RW Facility 2/2023	360.00
70202	3/9/2023	Aqua Natural Solutions	Microbe Lift 3/2023	1,211.04
70203	3/9/2023	Bayside Equipment Company	Vehicle Maintenance Unit 216, 218, 200	855.98
70204	3/9/2023	CWEA	CWEA ECI Certificate Renewal A.Patino 2/2023	95.00
70205	3/9/2023	California Water Service	Water Service - Seminary Pump Station 1/25/23-2/22/23	42.95
70206	3/9/2023	CalPERS Longterm Care Program	LTC Withholding 2/16/23-2/28/23	67.27
70207	3/9/2023	Cintas	Uniform Service 3/1/23	1,075.55
70208	3/9/2023	Cleanserv Universal Services	Janitorial Service 3/2023	1,075.00
70209	3/9/2023	Comcast	Internet - 500 Laurel St 2/20/23-3/19/23	336.76
70210	3/9/2023	CPS HR Consulting	HR Consulting Services 1/2023	445.00
70211	3/9/2023	Du-All Safety, LLC	Safety Maintenance Contract 2/2023	1,800.00
70212	3/9/2023	Navia Benefit Solutions	Commuter & FSA Fees 2/2023 FSA Contributions PR 3/10/23	831.15
70213	3/9/2023	Freyer & Laureta	CIP Point Repair & Levee Design, Bayfront Park Construction Consulting	125,257.14
70214	3/9/2023	Freyer & Laureta	Staff Augmentation Services 1/2023	26,880.00
70215	3/9/2023	Frisch Engineering, Inc.	SHRWF Programming Integration 2/2023	1,462.50
70216	3/9/2023	Golden State Reprographics LLC	Scanning and Uploading Plan Sets for Pump Stations 2/2023	108.65
70217	3/9/2023	Home Depot Credit Services	Tools, Wood, & Supplies 2/2023	498.68
70218	3/9/2023	IEDA	Consulting Fees 3/2023	814.00
70219	3/9/2023	Kone Pasadena	Elevator Maintenance 3/2023	298.69
70220	3/9/2023	City Of Menlo Park - Water	Water Service - Jan-Feb 2023	107.25
70221	3/9/2023	City Of Menlo Park-Fuel	Fuel: District Vehicles 2/2023	9,988.21
70222	3/9/2023	Abila	MIP Cloud Subscription 4/4/23-5/3/23	652.67
70223	3/9/2023	Ovivo Usa, LLC	Service Contract - 2yr - SHRWF 2/2023	6,525.00
70224	3/9/2023	Pacific Gas & Electric	Electric Service - Jan-Feb 2023	6,352.38
70225	3/9/2023	D&J Gardening	Landscaping - Laurel St 2/2023	400.00
70226	3/9/2023	Recology Peninsula Services	Recology Waste 2 Yard Bin - SHGCC 2/2023	249.39
70227	3/9/2023	Seekzen Systems	IT Consulting Service 2/2023	475.00
70228	3/9/2023	Sharp Business Systems	Monthly Lease for Copiers 3/2023	1,206.28
70229	3/9/2023	Streamline	One-time Website Migration Services Fee 2/2023	250.00
70230	3/9/2023	TPX Communications	District VoIP & Fiber Service 2/2023	3,239.26
70231	3/9/2023	Towne Ford	Unit 210 Service, Unit 209 Glow Plug Replacement 2/2023	2,158.42
70232	3/9/2023	U.S. Jetting, LLC.	Pump Repair and Parts 1/2023	119.99
70233	3/9/2023	Verizon Wireless	Internet 2/2/23-3/1/23	65.69
70234	3/9/2023	Weco Industries	Sewer Cleaning Equipment 2/2023	2,973.73
70235	3/9/2023	Jonathan Werness	J.Werness: PERS 2017 Unreported PR Interest Chg	154.44
70236	3/14/2023	Airgas Usa, LLC	Tank Rentals 2/2023	50.38
70237	3/14/2023	CDW Government	Microsoft Office 365 (Plan G3 and G1) Subscription License	6,073.54
70238	3/14/2023	CalPERS Longterm Care Program	LTC Withholding 3/1/23-3/15/23	67.27
70239	3/14/2023	Core & Main	Couplers & Supplies 2/2023	3,213.62
70240	3/14/2023	Du-All Safety, LLC	Standard Operating Procedures Development 2/2023	1,980.00
70241	3/14/2023	FedEx	HR Shipping Charges 2/27/2023	59.57
70242	3/14/2023	Grainger	Pump Station Parts & Material & PPE 3/2023	476.09
70243	3/14/2023	Granite Rock Company	Asphalt, Concrete & Rock Rehab - 2/2023	263.52
70244	3/14/2023	Interstate Traffic Control	Road Signs 2/2023	30.63
70245	3/14/2023	Menlo Park Hardware Co. #14016	Miscellaneous Parts & Tools 2/2023	164.58
70246	3/14/2023	Mission Clay Products, LLC	Clay, Wye, & Tees 2/2023	3,141.08
70247	3/14/2023	Pacific Gas & Electric	Electric Service - Georgia Ln 1/30/23-2/28/23	656.15
70248	3/14/2023	PBM	Gloves, Broom 2/2023	160.64
70249	3/14/2023	Red Wing Shoe Store	Safety Boots 2/2023	966.94
70250	3/14/2023	Registrar Of Voters	Fees for General Election 11/8/22	2,524.00

West Bay Sanitary District

Financial Activity Report

Withdrawals

March 2023

70251	3/14/2023	Rich Voss Trucking	Rock Delivery 02/2023	320.00
70252	3/14/2023	San Mateo Lawn Mower Shop	Tune Up for Generator 2/2023	371.38
70253	3/14/2023	Seekzen Systems	Synology Backup to Replace Barracuda 2/2023	7,825.00
70254	3/14/2023	Steven Creek Quarry	Base Rock 2/2023	1,003.96
70255	3/14/2023	Teletrac Navman US	Vehicle GPS 3/2023	271.96
70256	3/14/2023	V & A Consulting Engineers	Master Plan: V&A Flow Monitoring Study 2/2023	9,404.00
70257	3/14/2023	Vision Communications Co.	Radio Air Time 3/2023	724.13
70258	3/14/2023	Young's Auto Supply Center	Unit 210: Auto Parts 3/2023	206.45
70259	3/16/2023	Javier Hernandez	Payroll 03/04-16/2023 Final Check	1,798.20
70260	3/22/2023	AT&T	Telemetry & Alarms 2/13/23-3/12/23	1,174.73
70261	3/22/2023	Alpha Analytical Laboratories	Daily Coliform Samples - SHGCC RW Facility 2/2023	360.00
70262	3/22/2023	ReadyRefresh By Nestle	Water Delivery - 2/11/23-3/10/23	169.27
70263	3/22/2023	Atchison, Barisone & Condotti	Legal Services 2/2023	14,545.03
70264	3/22/2023	Backflow Prevention Specialist	Test and Certify (18) Backflow Prevention Devices 3/2023	2,715.00
70265	3/22/2023	California Water Service	Water Service - Feb-Mar 2023	1,906.83
70266	3/22/2023	Cintas	Uniform Service 01/2023	4,005.07
70267	3/22/2023	City Of Foster City	CalOpps - Associate Engineer Posting 3/2023	540.00
70268	3/22/2023	Comcast	Internet - Sand Hill Rd 3/18/23-4/17/23	287.52
70269	3/22/2023	Core & Main	Couplers & Supplies 2/2023	3,466.34
70270	3/22/2023	CPS HR Consulting	HR Training A.Bergeron 1/31/23-2/21/23	650.00
70271	3/22/2023	Dolphin Graphics	West Bay Apparel 3/2023	577.78
70272	3/22/2023	Navia Benefit Solutions	FSA Contributions PR 3/24/23	631.15
70273	3/22/2023	Freyer & Laureta	Levee Design, Bayfront Park, CIP Point Repair Design, Avy PS Design	53,171.50
70274	3/22/2023	Grainger	Misc.Parts & Supplies 3/2023	737.80
70275	3/22/2023	Hach Company	Flo-Dar Replacement Program 2023 (2)	39,102.50
70276	3/22/2023	Hillyard/San Francisco	Paper Towel Restock Admin 1/2023	691.29
70277	3/22/2023	Ironhouse Sanitary District	Annual Membership Western Recycled Water Coalition 2023	2,713.45
70278	3/22/2023	Eric Madrigal	Office of Water Programs:Collection Systems Class E.Madrigal	75.00
70279	3/22/2023	Mallory Co.	PPE Supplies 3/2023	2,357.34
70280	3/22/2023	City Of Menlo Park - Water	Water Service - Feb-Mar 2023	510.77
70281	3/22/2023	Motion Industries	Lay Flat Hose for Bypass Pumps (12)	6,834.69
70282	3/22/2023	Pacific Gas & Electric	Electric Service - Feb-Mar 2023	209.03
70283	3/22/2023	D&J Gardening	Landscaping - Laurel St 3/2023	400.00
70284	3/22/2023	County Of San Mateo	LSSA Recording Fee: 915 Marsh Rd, MP	20.00
70285	3/22/2023	County Of San Mateo	Notice of Exemption - Misc. Areas	50.00
70286	3/22/2023	County Of San Mateo	LSSA Recording: 10 Garland Pl, MP	20.00
70287	3/22/2023	County Of San Mateo	LSSA Recording: 339 Hedge Rd, MP	20.00
70288	3/22/2023	Shape	E-one Grinder Panel 3/2023	889.22
70289	3/22/2023	Leaf Capital Funding	Fujitsu Scanner Monthly Lease 3/2023	462.99
70290	3/22/2023	Woodard & Curran	Avy PS SRF Application 12/2022	3,145.00
70291	3/29/2023	Alpha Analytical Laboratories	Daily Coliform Samples - 3/2023	180.00
70292	3/29/2023	Angulos NorCal Tree Service	Emergency Tree Removal at Corte Madera Pump Station 3/2023	1,500.00
70293	3/29/2023	Bay Alarm	Alarm Monitoring - Laurel St 4/1/23-7/1/23	2,970.99
70294	3/29/2023	Bay Area Paving Co.	Asphalt Replacement: MP 3/2023	27,400.00
70295	3/29/2023	CWEA	CWEA Membership Renewal and Testing Fee 3/2023	397.00
70296	3/29/2023	CSRMA C/O Alliant Insurance	Vehicle Insurance Premium Adj. 10/2022-12/2022	614.00
70297	3/29/2023	CalPERS Longterm Care Program	LTC Withholding 3/16/23-3/31/23	67.27
70298	3/29/2023	Comcast	Internet 3/20/23-4/19/23	346.78
70299	3/29/2023	FedEx	Shipping Charges 3/2023	702.73
70300	3/29/2023	Grainger	Tools Stock 3/2023	848.79
70301	3/29/2023	Hach Company	Service Contract - Flo Dar Maintenance & Reporting 3/2023	12,993.75
70302	3/29/2023	Sutter EAP	Quarterly EAP Charges - Q1 2023	422.75
70303	3/29/2023	R.A. Nosek Investigations	New Hire Background Check - D'Andre W. 3/2023	315.00
70304	3/29/2023	Ovivo USA, LLC	HMI Panel Replacement - SHRWF 3/2023	5,171.28
70305	3/29/2023	P&F Distributors	Force Main Emergency Repair Parts 3/2023	2,228.13
70306	3/29/2023	Pacific Gas & Electric	Electric Service - Feb-Mar 2023	2,132.45
70307	3/29/2023	Preferred Alliance	DOT Testing Admin Fees 2/2023	280.80
70308	3/29/2023	Samuel M. Rose	Consulting 2/22/23-3/20/23	360.00
70309	3/29/2023	County Of San Mateo	Notice of Exemption - 20 Shoshone Pl, PV 2/22/2023	50.00
70310	3/29/2023	Staples Credit Plan	Office Supplies 3/2023	377.53
70311	3/29/2023	Towne Ford	Unit 210: Repair Unit 208: TCM Replacement 3/2023	14,347.90
70312	3/29/2023	Underground, Inc.	Unit 226 Camera Box 12/2021	165.89
70313	3/29/2023	US Standard Products Corp	PPE 1/2023	1,708.24
70314	3/29/2023	Verizon Wireless	District Cellphones 2/16/23-3/15/23	2,142.22
70315	3/29/2023	Woodard & Curran	Woodside Reclaimed Water Facility Plan 2/2023	22,377.75

Checks

716,536.28

**West Bay Sanitary District
Financial Activity Report
Withdrawals
March 2023**

Corporate Cards:

GL	Date	Account Name	Description	Amount
12000	3/6/2023	Accounts Receivable	Starbucks: S.Ramirez Personal Expense 2/6/23 (to be reim)	21.20
21000	3/6/2023	Accounts Payable	CalCard: Short Payment Stmt 1/25/23	194.70
54028	3/6/2023	Commuter Benefits	Fastrak: Commuter Expenses	1,180.00
54080	3/6/2023	Memberships	Peloton: Annual Membership CWEA: Membership Renewals	775.00
54091	3/6/2023	Stationary and Office Supplies	Office Supplies	1,576.41
54092	3/6/2023	Periodicals & Printer Supplies	Ink for Printer	87.38
54101	3/6/2023	Ops Supplies & Materials	Operating Supplies	651.55
54103	3/6/2023	Vehicle & Equipment Supplies	Custom Truck: Mach E Bike Rack & Tow Hitch	1,441.69
54104	3/6/2023	Cleaners, Paint, & Chemicals	Cleaning Detergents	350.21
54126	3/6/2023	Safety Training	Beverages & More: Safety Recognition - Gift Card	10.00
54129	3/6/2023	Recruitment	CWEA: Job Posting Associate Engineer	305.00
54131	3/6/2023	Advertisement & Legal Notices	The Daily Post: CIP Point Repair Bid Ad	675.00
54132	3/6/2023	Printing Forms & Cards	SMC Recorder: Easement Documents	70.00
54151	3/6/2023	Fleet/Vehicle R&M	Unit 224: Vehicle Wash Unit 230: Vehicle Charging	189.96
54154	3/6/2023	Mobile & Non-mobile Equip R&M	Auto Parts, and Hose Equipment	2,065.36
54157	3/6/2023	Building Repairs & Maint.	SP Ghost Controls: Admin Gate Battery Backup	130.16
54158	3/6/2023	Computer Software R & M	Subscriptions: Duo, Zoom, Log Me In, Blue Beam	2,879.48
54159	3/6/2023	Computer Hardware R & M	Hardware for Project Manager	748.24
54163	3/6/2023	Recycled Water Monitoring	Amazon: Dynalon HDPE Sampler/Dipper, pH Buffer Calibration Solution, Sludge Juc	553.70
54173	3/6/2023	Dept Training & EE Development	Lunch for Crews	401.34
54174	3/6/2023	Mgmt Conf. & District Meetings	District Meetings	822.80
54175	3/6/2023	CWEA Conf/Section Mtgs	CWEA Banquet Awards & Conference	2,091.86
54176	3/6/2023	Business Meetings	CWEA Conference, Business Meetings	1,381.85
54191	3/6/2023	Internet	Comcast: Internet - SHRWF	171.76
54203	3/6/2023	Licenses & Permits	Encroachment Permit, CA Air Resource Board Permit	2,827.28
US Bank CalCards (Visa)				21,601.93

Bank Transfers:

Date	Payee	Purpose	Amount
3/2/2023	Paytrace	Credit Card Processing Fees	682.36
3/3/2023	SVCW	SVCW Monthly Operating Contribution	591,557.00
3/3/2023	ADP	ADP Fees	290.00
3/8/2023	CalPERS	Retirement Contributions PR 2/24/2023	24,885.42
3/9/2023	ADP	Payroll Taxes - Board	696.06
3/9/2023	ADP	Payroll Taxes - 03/10/2023	41,970.16
3/9/2023	ADP	Director Fees Feb 2023	3,484.93
3/9/2023	ADP	Employee Payroll - Check Date: 03/10/2023	135,406.01
3/10/2023	MissionSquare	Deferred Compensation, Formerly: ICMA	13,160.69
3/10/2023	NeoPost	Postage	300.00
3/13/2023	CalPERS	Health Premiums	60,917.27
3/16/2023	CalPERS	Retirement Contributions PR 3/10/2023	24,913.55
3/17/2023	ADP	ADP Fees	320.00
3/20/2023	Bank of the West	Fees	164.66
3/23/2023	ADP	Payroll Taxes - 3/24/2023	38,820.67
3/23/2023	ADP	Employee Payroll - Check Date: 03/24/2023	129,985.22
3/24/2023	MissionSquare	Deferred Compensation, Formerly: ICMA	13,160.69
3/30/2023	CA Water Boards SWRCB	SHRWF SRF Loan Payment	662,910.88
3/31/2023	ADP	ADP Fees	275.00
3/31/2023	CalPERS	Retirement Contributions PR 3/24/2023	24,788.96
Bank Wires & ACHs			1,768,689.53

Date	Payee	Purpose	Amount
3/29/2023	Public Agency Retirement Services (PARS)	2022/23 Contributions	75,000.00
Internal Bank Transfers			75,000.00

Summaries:

Withdrawal Summary

Total Checks	716,536.28
Total Corp Card	21,601.93
Total Bank Wires / ACHs	1,768,689.53
Total Internal Bank Transfers	75,000.00
Total Withdrawals	2,581,827.74

West Bay Sanitary District
Expenditures By Vendor
7/01/2022 to 03/31/2023

Withdrawals	Total by Vendor YTD FY 2022-23	Withdrawals March 2023
3600 Haven Avenue, LP	38,939.80	38,939.80
AAA Fire Protection Services	1,323.05	-
AAA Rentals	12,980.98	1,151.50
A-A Lock & Alarm	644.07	79.59
Svend Aagesen	1,483.53	1,483.53
Ace Fire Equipment & Service	2,342.38	2,342.38
Action Towing	1,922.50	518.50
Abila	9,910.08	652.67
Fumio Adachi	1,483.53	1,483.53
ADP Fees	6,601.40	885.00
ADP-Wage Garnishment	5,721.53	-
Aerzen USA Corp.	2,400.00	-
Airgas Usa, LLC	796.03	50.38
Stephen Albano	39,231.90	-
Allied Crane	955.18	-
The Almanac	11,502.56	-
Alpha Analytical Laboratories	12,320.00	900.00
American Highway Products	536.52	-
Larry & Mary Anderson	1,483.53	1,483.53
Domenic Andrighetto	471.87	-
Angulos NorCal Tree Service	1,500.00	1,500.00
Aqua Natural Solutions	2,422.08	1,211.04
AT&T	10,584.46	1,174.73
Atchison, Barisone & Condotti	93,328.36	22,964.73
Seth Avila	500.00	-
Jancie L. Avilla	1,483.53	1,483.53
Aztec Consultants	15,722.05	-
BAGG Engineers	6,665.00	-
Backflow Prevention Specialist	2,715.00	2,715.00
Bank of the West - Credit Cards	66,439.60	-
Bank of the West	1,954.86	164.66
Battery Junction Wholesale	3,338.29	860.86
Bay Alarm	22,917.85	3,767.49
Bay Area Air Quality Mgmt Dist	3,716.00	916.00
Bay Area Barricade Service Inc	1,936.33	-
Bay Area Paving Co.	56,573.00	33,300.00
Bay Reprographic, Inc.	530.48	-
Bayside Equipment Company	3,497.36	855.98
Claude Michael Beasley	1,483.53	1,483.53
Annette Bergeron	7,571.48	-
Jed M. Beyer	96.50	-
Blackburn Manufacturing Co	1,391.48	-
Bonny Doon Environmental	983.76	-
Richard W. & Sandra W. Boyce	3,494.44	-
Bosco Oil Inc DBA Valley Oil	322.09	-
Patricia Burns	1,483.53	1,483.53
CA Dept Of Tax & Fee Admin	-	-
CASA	14,300.00	-
CA State Disbursement Unit	-	-
CPS HR Consulting	2,836.25	1,095.00
Calgon Carbon Corporation	3,084.16	-
Calif. Labor Law Poster Service	192.00	-
CA Regional Water Quality	25,637.00	-
California Car Sounds, Inc.	8,187.34	-
California Water Service	25,035.35	2,087.59
CA Water Boards SWRCB	662,910.88	662,910.88
CalPERS - Actuary Fee	-	-
CalPERS - Admin Fees	600.00	-
CalPERS - Unfunded Accrued Liability	10,690.00	-
CalPERS - GASB Fee	1,050.00	-
CalPERS - Retirement	506,171.58	74,587.93
CalPERS - Health Premiums	519,171.28	60,917.27
CalPERS - 1959 Survivor Billing	1,677.90	-
CalPERS Longterm Care Program	1,116.29	201.81
Carla Carstens	5,521.53	-
Martin & Kristen Casado	1,483.53	1,483.53
CDW Government	6,073.54	6,073.54
Michael Chang	1,263.16	-
Chavan & Associates	14,000.00	-
ChemsearchFE	625.57	-
George Choi & Michele Ono	3,494.44	-
Cintas	36,963.45	6,114.59
City of Foster City	2,680.00	540.00
City of Menlo Park	615.02	-
City of Menlo Park-Fuel	111,989.66	9,988.21
City of Menlo Park - Water	14,572.42	1,112.41
Thomas Robert Clandinin	1,483.53	1,483.53
Cleanserv Universal Services	10,246.98	1,075.00
Comcast	5,297.36	1,243.35
The Concept Genie	8,236.37	-
Consolidated Parts, Inc	5,084.39	-
Core & Main	32,985.88	6,679.96
Corrosion Protection Solutions	3,860.00	-
Heath Cortez	249.19	-
Costco	60.00	-
Tracy & Peter Cowperthwaite	1,483.53	1,483.53
CSDA	8,810.00	-
CSMA c/o Alliant Insurance	359,075.37	614.00
CTJ	1,483.53	1,483.53
Cues, Inc.	3,950.00	-

West Bay Sanitary District
Expenditures By Vendor
7/01/2022 to 03/31/2023

Withdrawals	Total by Vendor YTD FY 2022-23	Withdrawals March 2023
Sean A. Curran	1,483.53	1,483.53
CWEA	2,044.00	1,354.00
D&J Gardening	1,200.00	800.00
Stephen Daane & Sheryl Garrett	1,483.53	1,483.53
Lyn Louise Dearborn	1,483.53	1,483.53
Alan & Lauren Denenberg	3,494.44	-
Dewey Pest Control	18,185.00	-
Dolphin Graphics	6,811.53	577.78
Palwasha & Zelikha Dost	1,483.53	1,483.53
David Douglas	27.39	27.39
Du-All Safety, LLC	18,180.00	3,780.00
Ronald Dalman & Jocelyn Dunn	471.87	-
Lois DuBois	1,483.53	1,483.53
David L. & Julie Duncan	2,967.06	2,967.06
Duke's Root Control, Inc	267,966.64	-
Stephen Dunne	4,450.59	4,450.59
EDD	124.87	-
Ian Earnest	2,967.06	2,967.06
Ergoworks	36.88	-
Fast Response On-Site Testing	1,742.40	-
FedEx	2,881.37	762.30
Fischer Compliance LLC	15,825.00	-
James H. Foster	1,483.53	1,483.53
Freyer & Laureta	871,514.31	205,308.64
Frisch Engineering, Inc.	1,462.50	1,462.50
Mary Ann H. Furda	1,483.53	1,483.53
Dorothy Garcia Bachler	3,494.44	-
Scott & Jennifer Gamel	1,483.53	1,483.53
Tyler Garratt	10,345.71	10,345.71
Victor Garcia	476.40	-
Matt Gebhart	1,483.53	1,483.53
Global Equipment, Inc	531.61	-
Golden State Reprographics LLC	846.17	108.65
Goldstreet Design Agency, Inc.	4,000.00	-
Govconnection, Inc.	1,697.76	-
Governmentjobs.Com, Inc	4,479.01	-
Grainger	32,742.83	5,798.89
Granite Rock Company	2,779.86	263.52
Gurtner Living Trust	471.87	-
HF&H Consultants	21,390.00	-
Hach Company	164,085.62	52,096.25
Hadronex, Inc.	41,545.86	-
Jerald Hall Jensen	1,483.53	1,483.53
Harben California	5,769.81	-
Ann Hardy	1,483.53	1,483.53
Ingrid B. Hardy	1,483.53	1,483.53
Harrington Industrial Plastics	301.73	-
Yvonne Harrosh	25,848.00	-
Haas & Hayne	1,040.82	1,040.82
Elizabeth Hayden	10,345.71	10,345.71
Helix Laboratories, Inc.	2,764.03	-
Javier Hernandez	1,798.20	1,798.20
Hillyard/San Francisco	691.29	691.29
Home Depot Credit Services	6,394.88	498.68
John Paul Huetter	1,483.53	1,483.53
Bob Hulsmann	634.88	-
Mark & Rebecca Hilderbrand	3,494.44	-
ICMA	63,489.56	-
IEDA	7,326.00	814.00
Innovyze	9,035.00	-
Institute For Local Government	225.00	-
Interstate Traffic Control	183.76	30.63
Ironhouse Sanitary District	2,713.45	2,713.45
The Jensen Family Trust	1,483.53	1,483.53
Raivis Kampenuss	1,483.53	1,483.53
Mary Kelley & Marc Levaggi	1,483.53	1,483.53
Carol Kemper	1,483.53	1,483.53
Kimball Midwest	5,996.62	1,761.32
Bill Kitajima	30,768.33	-
Heather Kirkby	1,483.53	1,483.53
Judy Klein	5,521.53	-
Kone Pasadena	2,688.21	298.69
Alexander M. Kostrikin	1,483.53	1,483.53
Alison Krausz	471.87	-
Lasky Trade Printing	607.03	-
Leaf Capital Funding	4,213.21	462.99
Stone Lolohea	682.00	357.00
Dave Russell A Lojera	6,453.64	6,453.64
JoAnn Loulan	1,483.53	1,483.53
David A. Lowin	1,483.53	1,483.53
Gary Daniel MacGregor	1,483.53	1,483.53
Eric Madrigal	75.00	75.00
Mallory Co.	12,837.07	2,357.34
Charles & Toni Markley	2,967.06	2,967.06
Lisandro Marquez	250.00	-
Matheson Tri-Gas	659.75	60.60
David H. McMurtry	1,483.53	1,483.53
Medco Supply Company	790.18	-
Menlo Park Fire Protection	2,692.00	-
Menlo Park Hardware Co. #14016	804.80	164.58
Mid Peninsula Abstracts	830.00	-

West Bay Sanitary District
Expenditures By Vendor
7/01/2022 to 03/31/2023

Withdrawals	Total by Vendor YTD FY 2022-23	Withdrawals March 2023
Mid State Container Sales, Inc	5,185.00	-
Piterman Milanendra	-	-
Frazier Miller	1,483.53	1,483.53
Mission Clay Products, LLC	7,848.06	3,141.08
MissionSquare	-	26,321.38
Mission Valley Ford	5,957.00	-
Katrina Montinola	471.87	-
Morse Hydraulics	774.19	-
Motion Industries	6,834.69	6,834.69
Municipal Maintenance Equip.	15,455.38	-
Napa Auto Parts	1,902.55	-
National Auto Fleet Club	131,650.66	-
Navia Benefit Solutions	13,742.99	1,462.30
Paul Andrew Nelson	385.00	-
William E. Nelson	1,483.53	1,483.53
NeoPost	1,850.00	300.00
Nancy & Robert Neuer	1,483.53	1,483.53
Robert J. & Nancy J. Neuer	1,483.53	1,483.53
Carrie Nevoli - Petty Cash	342.20	-
Keri Nicholas	471.87	-
John Nightingale	1,483.53	1,483.53
North Bay Pensions	1,500.00	-
Stig & Holly Nybo	1,483.53	1,483.53
Occasions, Etc.	279.02	-
Occupational Health Centers	2,371.00	-
Ogasawara Landscape Maint.	6,030.00	-
Omega Industrial Supply	6,838.09	-
Ovivo Usa, LLC	11,934.66	11,696.28
P&F Distributers	2,228.13	2,228.13
PARS	-	-
Paxxo (USA) Inc	568.46	-
PBM	3,094.62	160.64
Pacific Gas & Electric	240,475.52	22,087.57
Paytrace	5,587.53	682.36
Lynne Penek - Holden	1,483.53	1,483.53
Peninsula Truck Repair	17,567.97	-
Pier 2 Marketing	1,500.00	-
Charles A. Planje	1,584.00	-
Ponton Industries, Inc.	3,554.69	-
Precise Printing And Mailing	3,940.82	-
Precision Engineering	914,052.95	-
Preferred Alliance	3,307.71	519.48
PrimePay Fees	956.25	-
Principal Life Insurance	56,496.23	6,858.51
Project Ergonomics	488.80	-
Quadient Leasing USA	805.25	-
Quincy Compressor	2,161.19	-
R.A. Nosek Investigations	2,711.00	315.00
R.D. Kincaide, Inc.	23,111.77	-
Readyrefresh By Nestle	3,267.18	532.53
Recology Peninsula Services	2,244.51	249.39
Red Wing Shoe Store	6,201.31	966.94
Redwood City Health & Wellness	256.50	-
Redwood General Tire Co	3,794.62	-
City Of Redwood City	9,678.32	-
Todd Reese	225.00	-
Keith Reeves	1,483.53	1,483.53
Registrar Of Voters	2,524.00	2,524.00
Rich Voss Trucking	900.00	320.00
Sean Riley & Judy Riley	1,483.53	1,483.53
Nicolas Rochard & Leigh Birch	1,483.53	1,483.53
Samuel M. Rose	1,650.00	360.00
Cindy Lee Russell	1,483.53	1,483.53
Kent Ryhorchuk & Cathy Brewer	1,483.53	1,483.53
SVCW - Monthly Operating Contribution	5,324,013.00	591,557.00
SVCW 2018 Bonds	1,833,999.48	-
SVCW 2021 A-B Bonds	2,736,917.22	-
SVCW - SRF Debt	506,765.21	-
Silicon Valley Clean Water	2,925.00	-
Michael Scandalios	471.87	-
Rupert Sandoval	200.00	-
County of San Mateo	373.00	160.00
San Mateo County Assessor	-	-
San Mateo County Tax Collector	990.00	-
San Mateo County Health	3,360.00	-
County of San Mateo - LAFCO	22,323.00	-
San Mateo Lawn Mower Shop	1,229.50	371.38
County of Santa Clara	-	-
SWRCB	18,512.00	-
Victoria S. Sargent	1,483.53	1,483.53
Robert J. Scheidt	821.03	-
Thomas & Jean Schellenberg	1,483.53	1,483.53
Seekzen Systems	60,639.00	8,300.00
Sensera Systems	2,148.00	-
Shape	55,193.91	889.22
Sharp Business Systems	10,876.37	1,206.28
Bob Sick	1,587.36	-
Daniel Siegel	471.87	-
Signa Mechanical	343.25	-
Thomas W. Sisson	1,483.53	1,483.53
Spartan Tool	4,121.05	-

West Bay Sanitary District
Expenditures By Vendor
7/01/2022 to 03/31/2023

Withdrawals	Total by Vendor YTD FY 2022-23	Withdrawals March 2023
SPL Laboratories	2,728.50	-
David Stagg	1,483.53	1,483.53
Staples Credit Plan	5,976.59	377.53
Armin Staprans	1,483.53	1,483.53
Steven Creek Quarry	2,131.64	1,003.96
Streamline	250.00	250.00
Sutter EAP	1,239.75	422.75
TJB Investments LLC	25,394.71	-
TPX Communications	28,486.22	3,239.26
Teamsters Local No. 350	8,936.00	945.00
Teletrac Navman US	2,719.60	271.96
Telstar Instruments, Inc.	2,934.00	-
Thomas & Associates	491.92	-
William & Susan Thomas	3,494.44	-
Town Of Atherton	3,000.00	-
Towne Ford	102,435.99	16,506.32
Uline	955.33	-
Underground, Inc.	165.89	165.89
Underground Service Alert	13,714.45	-
Univar Solutions USA	9,266.17	-
John Urbanowiqz	5,521.53	-
Thomas V. & Nusrat T. Uridel	1,483.53	1,483.53
US Bank - CalCards - Credit Cards	18,494.14	-
U.S. Jetting, LLC.	2,344.26	119.99
US Standard Products Corp	2,650.56	1,708.24
V & A Consulting Engineers	59,620.26	9,404.00
Valley Heating & Cooling	2,270.00	-
Gregory G. Van Hauser	1,483.53	1,483.53
Veolia Water North America	365.43	-
Verizon Wireless	15,005.94	2,207.91
Video Voice Data Communication	10,708.95	-
Ramon & Kelly W. Villareal	3,494.44	-
Vision Communications Co.	14,729.14	724.13
Andrew & Kathy L. Waddell	3,494.44	-
Weco Industries	65,462.52	2,973.73
The Weed Solution	3,500.00	-
Mark Weiss	1,483.53	1,483.53
Jonathan Werness	154.44	154.44
West Yost & Associates	3,578.00	-
Western States Tool & Supply	523.42	-
Western Truck Fabrication, Inc	1,596.60	1,596.60
Erin & Julie Whalan	1,483.53	1,483.53
Stephen Wheeler	1,483.53	1,483.53
Israel White	1,436.71	-
Grover T. Wickersham	2,967.06	2,967.06
Blake Winchell	5,521.53	-
Woodard & Curran	244,115.07	38,032.75
Kenneth D. Woods	1,483.53	1,483.53
Young's Auto Supply Center	1,072.65	206.45
Zenon Environmental	8,739.07	-
Yanting Zhang	1,483.53	1,483.53
Zip's AW Direct	826.23	826.23
Total Vendor Withdrawals	17,470,894.27	2,134,862.76
<u>Wages & Payroll Taxes</u>		
Salaries/Wages - Net Pay	2,644,826.84	265,391.23
Directors Fees - Net Pay	28,309.97	3,484.93
Payroll Taxes	892,326.03	81,486.89
Performance Merit Program - Net Pay	213,353.66	-
Total Payroll	3,778,816.50	350,363.05
Total External Withdrawals	21,249,710.77	2,485,225.81
<u>WBSD Transfers:</u>		
WBSD LAIF Account	5,000,000.00	-
WBSD Investment Accounts	12,202,111.08	-
Public Agency Retirement Services (PARS)	75,000.00	75,000.00
Other Transfers	3,001,000.00	-
Total Transfers	20,278,111.08	75,000.00
Total Withdrawals	41,527,821.85	2,560,225.81



**WEST BAY SANITARY DISTRICT
AGENDA ITEM 3C**

To: Board of Directors

From: Bob Hulsmann, Operations Superintendent

Subject: WBSD Operations and Maintenance Report – March 2023

Month	Basin PM Pipe Clean-ing	High Freq. PM Pipe Clean-ing	Un-Sche. Pipe Clean-ing	WBSD CCTV Insp.	Pipe Patch Repairs	Open Trench Repairs	Pump Sta. PM	Pump Sta. Unsch. Repairs	SSO	SSO	Service Calls- Unit 208			
	Miles	Miles	Miles	Miles	Qty.	Qty.	Qty.	Qty.	Cat. 1	Cat. 2&3s	Call Outs	Sch PM	Unsch. PM	USA's
January	7.2	4.5	1.1	3.1	6	7	78	0	0	0	103	0	0	393
February	7.2	5.3	1.4	3.7	2	10	60	0	0	1	75	12	0	324
March	15.7	0.2	0.6	4.7	7	7	67	0	0	0	71	16	0	320
Yr to date	30.1	10.0	3.1	11.5	15.0	24.0	205.0	0.0	0.0	1.0	249.0	28.0	0.0	1037.0
2023 Goals	120.0	50.0	n/a	45-50	50-65	90	n/a	<10	<	4	n/a	n/a	n/a	n/a
2022 Results	120.9	53.6	7.5	**40.3	**92	100	774	0	1	2	858	97	2	3161
2021 Results	*123	*50	8.6	**46	**55	91	834	2	0	4	944	n/a	n/a	2294
2020 Results	134.2	51.0	8.4	29.6	72	85	754	6	0	0	1012	89	5	2362
2019 Results	112.0	48.2	6.9	42.7	60	86	967	6	0	4	1063	75	33	2850
2018 Results	134.2	48.5	7.4	42.1	66	63	1256	6	0	4	1139	134	89	2525
2017 Results	126.4	52	6	25	66	97	1265	8	2	3	700	178	61	3218

*** = Including TOW**

****= Including LAH and TOW**

THIS PAGE LEFT INTENTIONALLY BLANK



**WEST BAY SANITARY DISTRICT
AGENDA ITEM 3D**

To: Board of Directors

From: Bob Hulsmann, Operations Superintendent

Subject: Town of Los Altos Hills - Operations and Maintenance Report for Work Performed by WBSD – March 2023

Town of Los Altos Hills O & M Report 22/23									
	Basin PM Pipe Clean-ing	High Freq. PM Pipe Clean-ing	Un-Sche. Pipe Clean-ing	WBSD CCTV Insp.	Pump Sta. PM	Pump Sta. Unsch. Repairs	SSO	SSO	Service Calls
Month							Cat. 1	Cat. 2&3s	Call Outs
	Miles	Miles	Miles	Miles	Qty.	Qty.			
January	0.8	1.3	0.1	0.9	4	0	1	0	0
February	1.8	0.3	0.3	0.8	5	0	0	0	0
March	0.8	0.9	0	1.1	4	3	1	0	0
April	0	1.6	0.3	0	4	0	0	0	0
May	1.5	1.6	0	0.8	4	0	0	0	0
June	3	0.5	0.1	0.5	4	0	0	0	0
July	1.2	0.5	0	0.9	4	0	0	0	0
*August 22	0.1	1.1	0	0.9	4	0	0	0	0
Sept.	1.6	1.3	0.1	0.9	4	0	0	0	0
Oct.	0.9	1.4	0.4	1.1	4	0	0	0	0
Nov.	0.4	1.3	0	1.1	4	0	0	1	1

Dec	0.3	1.4	0	0.5	4	0	0	0	0
** Yr to date	12.4	13.2	1.3	9.5	48	3	2	1	1
FY22/23Goals	10.6	14.4	n/a	8.1	52	n/a	n/a	n/a	n/a

* = August- Start of Contract

	Goal	Total	Remain
Pipe Cleaning	25	26.9	-1.9
CCTV			
Inspection	8.1	9.5	-1.4



**WEST BAY SANITARY DISTRICT
AGENDA ITEM 3E**

To: Board of Directors

From: Bob Hulsmann, Operations Superintendent

Subject: Town of Woodside Operations and Maintenance Report for Work Performed by WBSD – March 2023



Yearly Summary Report

4/5/2023
8:06 AM

Dates Between 4/1/2022 and 3/31/2023

Month	Basin PM Pipe Cleaning (miles)	High Freq PM Pipe Cleaning (miles)	Unscheduled Pipe Cleaning (miles)	CCTV Inspection (miles)	Pump Stations Preventive Maintenance Qty	Pump Stations Unscheduled Repairs Qty	SSO Cat 1	SSO Cat 2 & 3	Service Calls Call Outs
January	0.0	0.0	0.0	0.0	8	0.0	1	0.0	0.0
February	0.00	0.0	0.0	0.0	8	0.0	0.0	0.0	0.0
March	0.00	0.3	0.0	0.0	8	7	0.0	0.0	0.0
April	0.00	0.0	0.0	1.1	10	0.0	0.0	0.0	0.0
May	0.00	0.0	0.0	0.0	8	0.0	0.0	0.0	0.0
June	0.00	0.3	0.0	0.0	8	0.0	0.0	0.0	0.0
July	0.00	0.0	0.0	0.0	8	0.0	0.0	0.0	0.0
August	0.00	0.0	0.0	0.0	8	0.0	0.0	0.0	0.0
September	0.19	0.3	0.0	0.0	8	0.0	0.0	0.0	0.0
October	0.00	0.0	0.0	0.0	8	0.0	0.0	0.0	0.0
November	0.00	0.0	0.0	0.0	8	0.0	0.0	0.0	0.0
December	4.43	0.0	0.0	0.0	8	0.0	0.0	0.0	0.0
Totals	4.62	0.8	0.0	1.1	98	7	1	0.0	0.0

Report to the District Board for the Regular Meeting of April 12, 2023

THIS PAGE LEFT INTENTIONALLY BLANK



WEST BAY SANITARY DISTRICT AGENDA ITEM 3F

To: *Board of Directors*

From: *Debra Fisher, Finance Manager*

Subject: *Bank of the West Monthly Investment Portfolio Statements*

Background

In October 2010 the District named Bank of the West as the District's Investment advisor and approved an investment of \$5 million in available funds to establish the Emergency Capital Reserve. Subsequently, the Board has established several additional reserves to provide financial stability for the District. On June 9, 2021, the Board approved the Operating Reserve increase to six months of operations, based on the current budget, held in the Local Agency Investment Fund (LAIF), in order to have the funds more accessible. This is necessary, as Operating Reserves are intended to fund the District between July 1st and December each year, when the County of San Mateo delivers the first installment of sewer service charges collected through tax rolls, which accounts for the majority of funding. On February 8, 2023, the Board approved the current Reserve Policy, which increased the Capital Projects and Emergency Capital Reserves by \$2 and \$1 million, respectively.

Excess funds over the current monthly expenditures are held in Local Agency Investment Fund (LAIF), which are equivalent to cash and may earn higher yields without a long term commitment. Operating Reserves, customer deposits, current capital projects, and Solid Waste Funds are held in LAIF.

Restricted funds for Sharon Heights Golf & Country Club (SHGCC), as required for the Clean Water State Revolving Fund (SRF) loan are held in a separate account.

There are currently five separate investment reserves maintained to support the goals of the District, along with reserves held in LAIF, the Vehicle & Equipment Reserve held in a money market account, and the restricted Pension Trust and Recycled Water State Revolving Fund (SRF) Reserves. Annual contributions are made in accordance with the Board approved budget in order to reach the target balances for each reserve.

<u>Reserve Account</u>	<u>Originated</u>	<u>Target Balance</u>	<u>Target</u>
Operating Reserve	11/26/2014	\$11.1 million	Achieved
Rate Stabilization Reserve	10/30/2015	\$10 million	Achieved
Treatment Plant Reserve	8/01/2021	\$12 million	Achieved
Capital Project Reserve	11/26/2014	\$8 million	Achieved
Emergency Capital Reserve	10/19/2010	\$6 million	Achieved
Recycled Water Cash Flow	11/18/2016	\$8 million	Achieved
Recycled Water SRF Reserve	3/01/2018	\$1.46 million	Achieved
Vehicle & Equipment Reserve	8/18/2011	\$1 million	Achieved

Fiscal Impact

The District has approximately \$81.7 million in all reserve and bank accounts as of March 31, 2023, including restricted funds. There was \$3.95 million in transfers in the approved FY 2022-23 Budget. The Board approved additional transfers on June 22, 2022, December 14, 2022, and February 8, 2023, for a total of \$15.2 million in transfers in FY 2022-23.

<u>District Funds</u>	<u>3/31/2023</u>
Cash Equivalent Accounts	35,283,959
Investment Accounts - Unrestricted	44,268,798
Public Agency Retirement Services (PARS Trust)	631,069
SHGCC SRF Loan Deposit	1,517,227
Total District Funds	81,701,051

Effective July 1, 2022, the Operating Reserve target increased to \$11.1 million for six months of operations, based on the approved budget for Fiscal Year 2022-23. As of March 31, 2023, all reserves have achieved the target balance of \$58.6 thousand. Due to fluctuations in market values, variances with the target balances vary, however principal is recovered as investments are held through maturity.

**Cash & Investments
March 31, 2023**

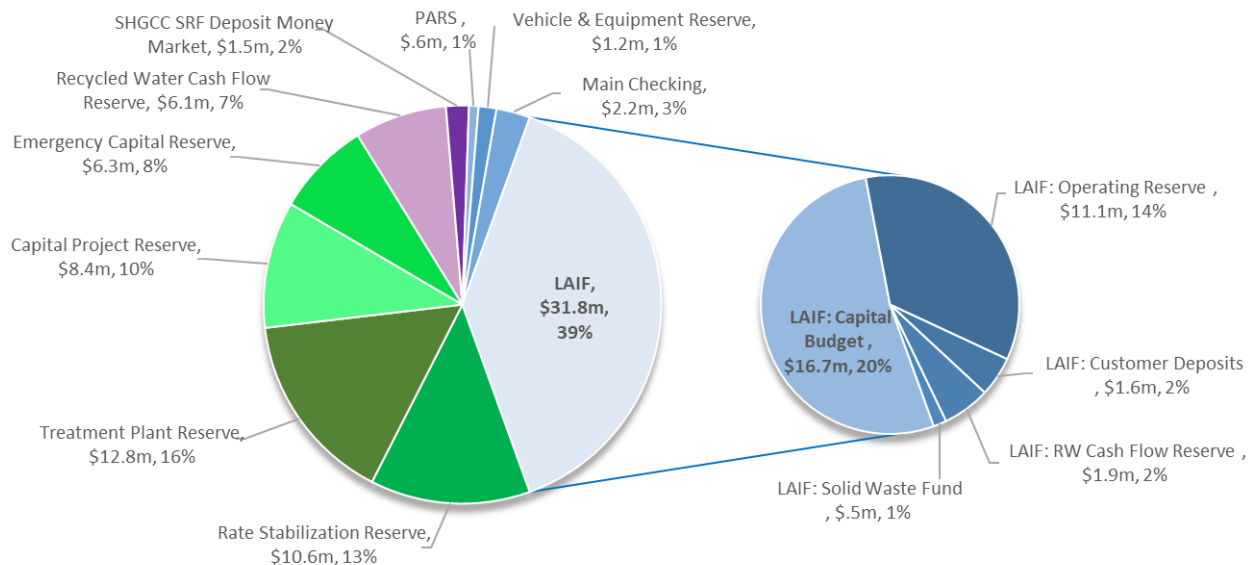

The monthly statement synopsis indicating the amount of each reserve fund the District holds in the Bank of the West Investment Portfolios are attached. Quarterly Treasury Reports will include details of investments of each reserve account.

Recommendation

The Finance Manager recommends the District Board accept the Investment Portfolio Statements by affirming and approving the items listed in the Consent Calendar.

Attached: 2023-03 Investment Reserve Accounts

WBSD - RATE STABILIZATION RESERVE

Account Number:
Statement Period:

03/01/23 -
03/31/23

WEST BAY SANITARY DISTRICT
500 LAUREL STREET
MENLO PARK CA 94025

Fiduciary

Chuen Ying Lee
(408) 645-3234

Portfolio

Michael D. Smith
(408) 490-2079

Asset Allocation

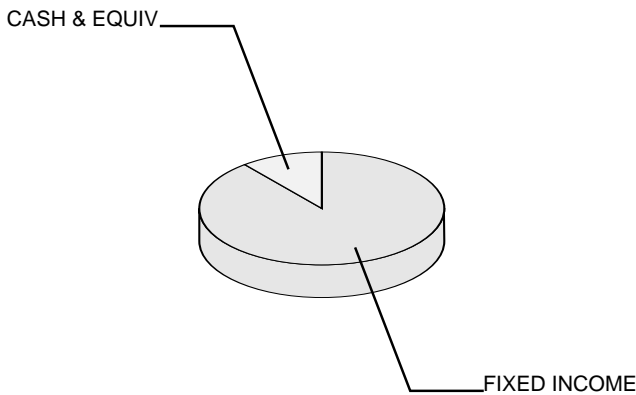

Asset Valuation

Description	Market Value	% of Account
Cash & Equiv	1,116,036.60	10.6%
Fixed Income	9,464,252.62	89.5%
Total Portfolio	\$ 10,580,289.22	100.0%
Accrued Income	55,423.22	
Total Valuation	\$ 10,635,712.44	

Market Reconciliation

	Current Period	Year To Date
Beginning Market Value	\$ 10,529,493.40	\$ 9,737,901.10
Income		
Interest.....	19,199.69	167,711.33
Purchased Income.....	0.00	-8,404.39
Additions.....	0.00	767,700.00
Disbursements.....	-1,368.50	-12,510.87
Realized Gains/(Losses).....	0.00	-60.87
Change In Accrued Income.....	624.08	3,548.71
Change In Market Appreciation/(Depreciation).....	98,632.87	50,262.76
Non-Cash Asset Changes.....	-10,869.10	-70,435.33
Ending Market Value	\$ 10,635,712.44	\$ 10,635,712.44

WBSD - TREATMENT PLANT RESERVE

Account Number:
Statement Period:

03/01/23 -
03/31/23

WEST BAY SANITARY DISTRICT
500 LAUREL STREET
MENLO PARK CA 94025

Fiduciary

Chuen Ying Lee
(408) 645-3234

Portfolio

Michael D. Smith
(408) 490-2079

Asset Allocation

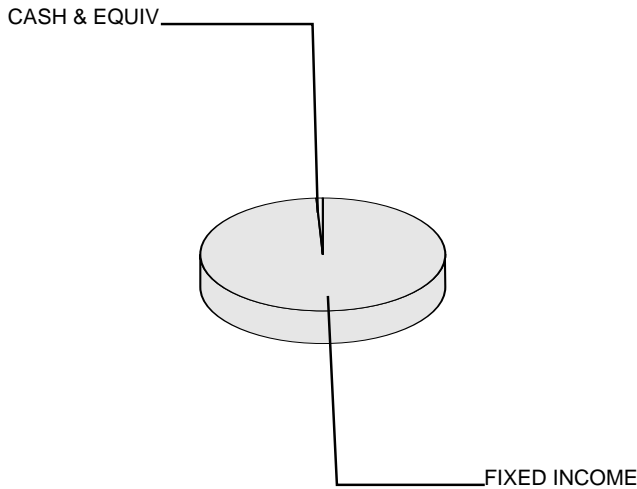

Asset Valuation

Description	Market Value	% of Account
Cash & Equiv	79,442.35	0.6%
Fixed Income	12,614,041.20	99.4%
Total Portfolio	\$ 12,693,483.55	100.0%
Accrued Income	69,238.53	
Total Valuation	\$ 12,762,722.08	

Market Reconciliation

	Current Period	Year To Date
Beginning Market Value	\$ 12,549,402.35	\$ 2,493,136.18
Income		
Interest.....	8,762.58	108,202.35
Purchased Income.....	0.00	-61,578.86
Additions.....	0.00	10,118,211.08
Disbursements.....	-1,632.20	-8,677.37
Realized Gains/(Losses).....	0.00	0.00
Change In Accrued Income.....	12,983.55	59,048.81
Change In Market Appreciation/(Depreciation).....	191,528.65	15,916.88
Non-Cash Asset Changes.....	1,677.15	38,463.01
Ending Market Value	\$ 12,762,722.08	\$ 12,762,722.08

WBSD - CAPITAL PROJECT RESERVE

Account Number:
Statement Period:

03/01/23 -
03/31/23

WEST BAY SANITARY DISTRICT
500 LAUREL STREET
MENLO PARK CA 94025

Fiduciary

Chuen Ying Lee
(408) 645-3234

Portfolio

Michael D. Smith
(408) 490-2079

Asset Allocation

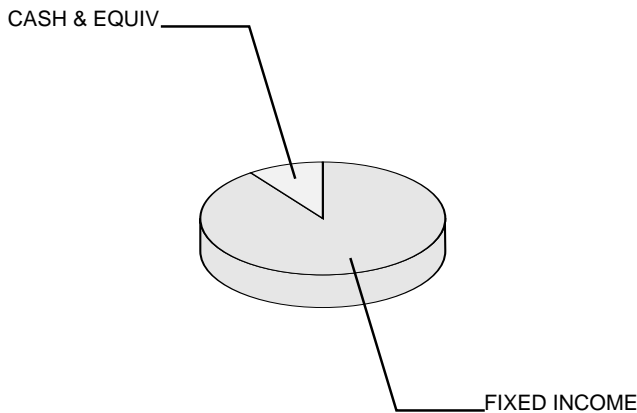

Asset Valuation

Description	Market Value	% of Account
Cash & Equiv	805,309.26	9.6%
Fixed Income	7,574,639.50	90.4%
Total Portfolio	\$ 8,379,948.76	100.0%
Accrued Income	33,247.41	
Total Valuation	\$ 8,413,196.17	

Market Reconciliation

	Current Period	Year To Date
Beginning Market Value	\$ 8,308,252.57	\$ 5,830,876.97
Income		
Interest.....	6,867.92	97,896.90
Purchased Income.....	0.00	-7,760.40
Additions.....	0.00	2,479,000.00
Disbursements.....	-1,081.88	-7,758.38
Realized Gains/(Losses).....	0.00	0.00
Change In Accrued Income.....	5,905.56	-1,335.67
Change In Market Appreciation/(Depreciation).....	88,090.62	45,828.22
Non-Cash Asset Changes.....	5,161.38	-23,551.47
Ending Market Value	\$ 8,413,196.17	\$ 8,413,196.17

WBSD - EMERGENCY CAPITAL RESERVE

Account Number:
Statement Period:

03/01/23 -
03/31/23

WEST BAY SANITARY DISTRICT
500 LAUREL STREET
MENLO PARK CA 94025

Fiduciary

Chuen Ying Lee
(408) 645-3234

Portfolio

Michael D. Smith
(408) 490-2079

Asset Allocation

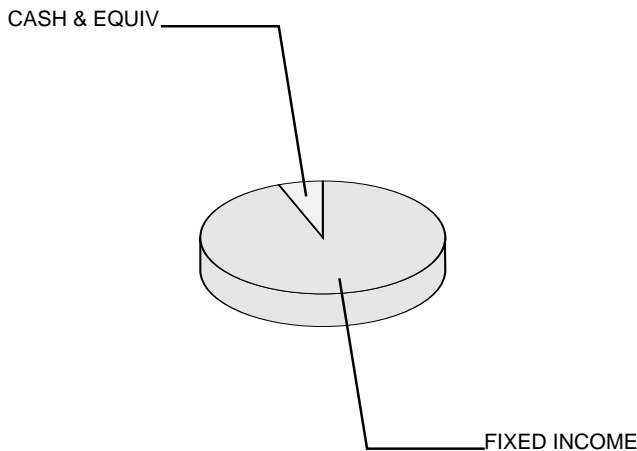

Asset Valuation

Description	Market Value	% of Account
Cash & Equiv	396,377.19	6.3%
Fixed Income	5,909,359.45	93.7%
Total Portfolio	\$ 6,305,736.64	100.0%
Accrued Income	29,967.18	
Total Valuation	\$ 6,335,703.82	

Market Reconciliation

	Current Period	Year To Date
Beginning Market Value	\$ 6,258,119.46	\$ 4,877,961.83
Income		
Interest.....	6,402.56	82,476.98
Purchased Income.....	0.00	-6,128.87
Additions.....	0.00	1,381,100.00
Disbursements.....	-814.16	-6,390.29
Realized Gains/(Losses).....	-326.06	-848.38
Change In Accrued Income.....	3,576.59	1,860.87
Change In Market Appreciation/(Depreciation).....	68,277.82	29,399.30
Non-Cash Asset Changes.....	467.61	-23,727.62
Ending Market Value	\$ 6,335,703.82	\$ 6,335,703.82

WBSD - RECYCLED WATER CASH FLOW

Account Number:
Statement Period:

03/01/23 -
03/31/23

WEST BAY SANITARY DISTRICT
500 LAUREL STREET
MENLO PARK CA 94025

Fiduciary

Chuen Ying Lee
(408) 645-3234

Portfolio

Michael D. Smith
(408) 490-2079

Asset Allocation

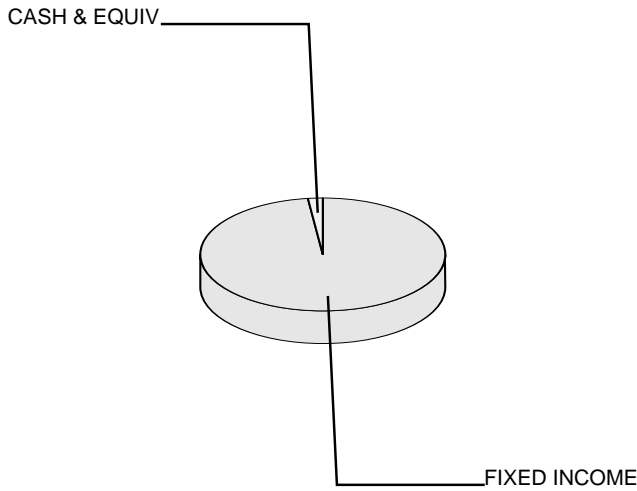

Asset Valuation

Description	Market Value	% of Account
Cash & Equiv	111,174.98	1.8%
Fixed Income	5,986,942.60	98.2%
Total Portfolio	\$ 6,098,117.58	100.0%
Accrued Income	23,345.46	
Total Valuation	\$ 6,121,463.04	

Market Reconciliation

	Current Period	Year To Date
Beginning Market Value	\$ 6,059,908.34	\$ 5,623,527.18
Income		
Interest.....	22,868.08	93,477.69
Purchased Income.....	0.00	-3,939.82
Additions.....	0.00	456,100.00
Disbursements.....	-787.06	-7,208.19
Realized Gains/(Losses).....	0.00	0.00
Change In Accrued Income.....	-12,369.42	-1,923.87
Change In Market Appreciation/(Depreciation).....	50,651.25	-57,185.56
Non-Cash Asset Changes.....	1,191.85	18,615.61
Ending Market Value	\$ 6,121,463.04	\$ 6,121,463.04

THIS PAGE LEFT INTENTIONALLY BLANK



To: Board of Directors
From: Sergio Ramirez, General Manager
Subject: General Manager's Report

1) Administrative:

- a. Staff met with Barker and Wagoner Architects to discuss the design of a new maintenance building. Barker and Wagoner Architects is preparing a proposal that would design a new maintenance building and will include cost estimates for construction. The design cost was approved in the FY22/23 budget.
- b. Staff has updated the General Code of Regulations, Standard Specifications, and Detail Drawings. General Counsel will review the items before staff brings it to the Board.
- c. The District will have a public outreach booth at the City of Menlo Park Easter Egg Hunt on Saturday, April 8th.

2) Finance:

- a. 0 Alpine Road requested a refund of the supplemental connection fee and standard sewer connection fee for approximately \$28,000. The property owners will not be moving forward with the project as planned and will be selling the property.
- b. The Meta finance agreement was signed. The agreement provides for 43.3 percent reimbursement for the Project Management costs by Meta.

3) CIP Projects:

a. Construction Capital Improvement Program (CIP):

- i. The Bayfront Park Sewer Improvements Project was awarded to Ranger Pipelines Inc. and will begin as materials are secured in the next month.

b. Levee Improvement Project:

- i. The Levee Improvement Project received permit approval by the Bay Conservation Development Commission on April 6, 2023, during its public meeting.
- ii. The City of Menlo Park approved the Levee Improvement Project encroachment agreement at the April 4, 2023, Council Meeting.

4) Information Technology (IT):

- a. Staff is working with Streamline on the new website. Roll out of the new site is scheduled for July 1, 2023.
- b. Staff successfully migrated to Microsoft Office 365 on March 29, 2023.

Report to the District Board for the Regular Meeting of April 12, 2023

Additional information or topics may be introduced by the GM verbally during the Board meeting.

- 5) **Operations and Maintenance:**
 - a. **Collection System:**
 - i. Crews responded to numerous power outages during the recent storms. Generators came on-line automatically as intended. Crews had to top off fuel to the generators as needed during the prolonged outages.
 - b. **Pump Facilities:**
 - i. The Pump Supervisor and Superintendent continue to research the replacement options for the outdated telemetry ISAC System and will report during the May 3rd budget workshop.
 - c. **Training:**
 - i. Staff and the General Manager will attend the California Water Environment Association's Annual Conference in San Diego for the first time in three years. The conference will be held from April 19th through April 21st.
- 6) **Water Quality:**
 - a. **Sharon Heights Golf and Country Club (SHGCC):**
 - i. The bid packet for the Avy Altschul Pump Station Project is being prepared and should be out for bids by April 15th.
 - b. **Bayfront Recycled Water Facility (BRWF):**
 - i. Project Management and Design has begun and should take approximately six months to be at the 30% design stage. The Recycled Water Committee will be asked to help select the Design Build Team to construct the facility. The project is expected to deliver recycled water by Q1 2026. A kick off meeting is scheduled for the week of April 9th.
 - c. **Woodside Recycled Water Facility (BRWF):**
 - i. The Woodside Recycled Water Facility feasibility will conclude soon. A full report will be brought to the District Board by Woodard & Curran.
- 7) **Fleet and Facilities:**
 - a. **Vehicle Maintenance:**
 - i. CSRMA approved a \$15,000.00 payout for the District Inspector's pickup truck which was struck by a fallen tree.
- 8) **Personnel:**
 - i. The Associate Engineering recruitment went well and an offer has been accepted by one of the candidates. We hope to bring our new Associate Engineer on by May 1st.
- 9) **Upcoming Events:**
 - a. **Next Regular Board Meetings:** Wednesdays, April 12th and April 22nd.
- 10) **Misc. Items:**
 - a. **West Bay:** The District experienced 1 sanitary sewer overflow (SSO) due to a forcemain break on the new Phil Scott Pump Station to the recycled water facility.
 - b. **Town of Los Altos Hills:** Crews assisted the Town with power outages.
 - c. **Town of Woodside:** Crews assisted the Town with bypassing the Town Square Pump Station due to the recent rain events.

Report to the District Board for the Regular Meeting of April 12, 2023

Additional information or topics may be introduced by the GM verbally during the Board meeting.



**WEST BAY SANITARY DISTRICT
AGENDA ITEM 5**

To:*Board of Directors*

From:*Sergio Ramirez, General Manager*

Subject:*Presentation by CitizenM Hotel located at 300 Constitution Drive,
Menlo Park*

CitizenM Hotel staff will present on the new hotel at 300 Constitution Ave. in Menlo Park.

District Staff and General Counsel has been working on wastewater flow entitlement for this project and have reached an agreement. A class 2 permit has been issued to allow for a connection to the public sewer system.

The presentation is for informational purposes.

THIS PAGE LEFT INTENTIONALLY BLANK



WEST BAY SANITARY DISTRICT AGENDA ITEM 6

To: *Board of Directors*

From: *Debra Fisher, Finance Manager*

Subject: *Consider Approving Closing of Andrighetto Reimbursement Agreement*

Background

On January 28, 2002 the District entered into a reimbursement agreement with Domenic Andrighetto, Alison Krausz, and Michael Scandalios for a sewer main extension to 235, 234, and 225 Shawnee Pass. The District reviewed the costs of the sewer main extension and determined that \$84,618 was eligible for reimbursement, as approved by the board on February 11, 2002 by adoption of Resolution 1471 (2002).

The original terms of the agreement will be fulfilled by the District after final payments are issued for 4 Navajo Place, 130 Shawnee Pass, 193 Meadowood Road, 20 Shoshone Place, for connections 21.85, 23.25, 24.25, and 25.25, respectively, with \$367.72 remaining on the total \$84,618 eligible for reimbursement.

The District will notify all parties, with final payments it has fulfilled its full obligation under the Agreement and the Agreement will be closed.

Fiscal Impact

The District has issued \$80,488.30 between 2002 and 2022 to the original contract parties, with \$4,129.70 remaining eligible reimbursement, per the agreement and \$3,761.98 outstanding on the 4.4 connections to the parties named above.

Options to Close Agreement:

1. Close agreement after current outstanding connections are completed and reimbursed. This will require a public hearing, per the agreement.
2. Keep open until additional connection is made and charge remaining balance on agreement or January 28, 2027, expiration date of contract, whichever comes first.
3. District pays remaining \$367.72 (\$122.57 each) to the three parties named in agreement, with current outstanding reimbursements, when completed, to fulfill complete eligible reimbursement, per the agreement.

Recommendation

The Finance Manager recommends the District Board approve the closing of the reimbursement agreement with Domenic Andrighetto, Alison Krausz, and Michael Scandalios.

Attached: Board Resolution 1471 (2002)
Andrighetto Reimbursement Agreement

RESOLUTION NO. 1471 (2002)

IN THE DISTRICT BOARD OF THE WEST BAY SANITARY DISTRICT
COUNTY OF SAN MATEO, STATE OF CALIFORNIA

BE IT RESOLVED that the President and Secretary of the West Bay Sanitary District be and are hereby authorized to execute the attached Reimbursement Agreement by and between the West Bay Sanitary District ("District") and Domenic Andrighetto, Alison Krausz and Michael Scandalios (Lands of Andrighetto, Krausz, and Scandalios) "Developer".

Passed and adopted by the District Board of the West Bay Sanitary District at a regular meeting thereof held on the 11th day of February 2002, by the following vote:

Ayes: CARCIONE, SHEPHERD, KNIGHT, LOMAX

Noes:

Abstain:

Absent: WALKER



President of the District Board of the West Bay
Sanitary District of San Mateo County, State of
California

Attest:

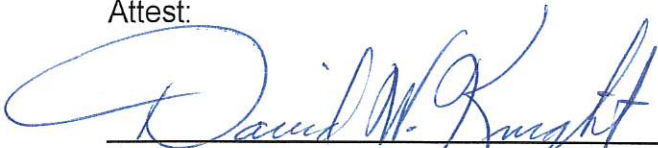

Secretary of the District Board of the West Bay
Sanitary District of San Mateo County, State of
California

SECRETARY, PRO TEM

**REIMBURSEMENT AGREEMENT
LANDS OF ANDRIGHETTO, KRAUSZ, AND SCANDALIOS
235, 234, and 225 SHAWNEE PASS, PORTOLA VALLEY**

This Agreement is entered into this 28th day of January, 2002, by and between the WEST BAY SANITARY DISTRICT, a public agency, hereinafter referred to as "District" and DOMENIC ANDRIGHETTO, ALISON KRAUSZ, AND MICHAEL SCANDALIOS, the other persons executing this Agreement, hereinafter referred to as "Developer."

RECITALS

A. Developer pursued and completed development activities on certain real property located in the territory of District and more particularly described in Exhibit "A" attached hereto ("the Real Property") for which it has been necessary for Developer to construct and install, at Developer's expense, certain wastewater collection and transmission facilities (the "Wastewater Facilities") to serve the development. The Wastewater Facilities are more particularly described in Exhibit "B" attached hereto.

B. The Wastewater Facilities are complete and on January 28, 2002 they were accepted by District and are now public property of District. The Wastewater Facilities have the potential to serve and benefit persons in the District in addition to those persons who may occupy the Real Property.

C. Because persons other than those who may occupy the Real Property may be served and benefited by the Wastewater Facilities, the parties agree that such persons should be required to reimburse Developer for their proportionate share of Developer's cost to construct and install the Wastewater Facilities.

D. District has reviewed the costs incurred by Developer and has determined that the total sum of Eighty four Thousand Six Hundred Eighteen Dollars (\$ 84,618.00) is eligible for reimbursement pursuant to the following Terms and Conditions of this Agreement.

In consideration of the foregoing Recitals and the following Terms and Conditions, District and Developer agree as follows:

TERMS AND CONDITIONS

1. Supplemental Connection Charge

a. In addition to the usual connection charges imposed by the District upon connection to the District's wastewater system, the District shall also impose a "Supplemental Connection Charge" for each connection to the Wastewater Facilities by any of the following persons (referred to in this Agreement as "Connectors"):

- (1) Any person, other than Developer, who makes an initial connection to the Wastewater Facilities;
- (2) Any person, other than Developer, who makes one or more additional connections to the Wastewater Facilities;

(3) Any person, other than Developer, who increases the discharge of wastewater through an existing connection to the Wastewater Facilities if that discharge exceeds the person's authorized discharge entitlement; and

(4) Developer, if Developer either (a) makes one or more additional connections to the Wastewater Facilities, or (b) increases the discharge of wastewater through an existing connection to the Wastewater Facilities so that the resulting discharge exceeds the Developer's authorized discharge entitlement; provided, however, that in either of the foregoing cases, the Supplemental Connection Charge otherwise payable by Developer will be waived if (a) there have been no prior connections to the Wastewater Facilities other than connections made by Developer, and (b) Developer executes an amendment to this Agreement in form and content acceptable to District which makes an appropriate adjustment in the "Cp" factor attributable to Developer.

For purposes of this Agreement, a connection includes both a connection of a building sewer to the Wastewater Facilities and a connection of an upstream sewer extension to the Wastewater Facilities.

b. Subject to the provisions of subparagraph 1.c. below, the amount of the Supplemental Connection Charge payable by each Connector shall be computed in accordance with the following formula:

$$SCC = \frac{ERC \times C_n \times (ENRC/ENRI)}{C_p + C_n}$$

Where:

SCC = The Supplemental Connection Charge to be paid by the new Connector.

ERC = The total eligible reimbursable cost specified in Recital D of this Agreement.

Cp = A factor representing the total wastewater contribution of all previous Connectors to the Wastewater Facilities measured in SFDE pursuant to subparagraph 1.d. below.

Cn = A factor representing the wastewater contribution of the new Connector to the Wastewater Facilities measured in SFDE pursuant to subparagraph 1.d. below.

ENRC = The ENR Construction Cost Index, rounded to the nearest whole number, for the month in which payment of the supplemental connection charge is made by the new connector.

ENRI = The ENR Construction Cost Index for the month in which the Wastewater Facilities were accepted by the District. ENRI shall be 6390.

c. Under no circumstances shall the amount of the Supplemental Connection Charge payable by a Connector exceed the estimated cost of constructing wastewater facilities from the Connector's property to the point where the Wastewater Facilities constructed by Developer connect to District's system. For this purpose, the estimated cost shall be determined by District.

d. Prior to the approval of a new connection to the Wastewater Facilities, the District Manager shall determine and establish the contribution of wastewater expected to be generated by the new Connector, measured in terms of single family dwelling equivalents ("SFDE"). Each single family dwelling unit shall be assigned a factor of 1 SFDE. All other uses shall be assigned an equivalency factor which is representative of the contribution of wastewater expected to be generated by the particular use. The equivalency factor shall take into account the volume of wastewater flows expected to be produced by the Connector and any other characteristics of the Connector's wastewater which may have an impact on the Wastewater Facilities. However, in no event shall any Connector be assigned an equivalency factor of less than 1 SFDE.

e. For purposes of this Agreement the amount of Cp attributable to Developer's wastewater contribution shall be 3 SFDE.

2. Collection of Supplemental Connection Charges

a. District shall use its best efforts to collect Supplemental Connection charges from all persons who become obligated to pay them. However, District may postpone or waive, in whole or in part, collection of any such charges if, after reasonable notice and hearing, the District Board, in the exercise of reasonable discretion, makes one of the following determinations:

- (1) Acting pursuant to Health and Safety Code Section 6520.6, the District Board determines the amount is too small to justify the cost of collection; or
- (2) The District Board determines that in the interest of the public health, safety and welfare, collection of the amount is not justified; or
- (3) The District Board determines that collection of the amount would pose an undue financial hardship on the new Connector.

If such a determination is made by the District Board, the determination shall be binding, and neither Developer, Connectors or any other person shall have a claim against District by reason of District's failure to collect any amount which is the subject of such a determination.

b. District's obligation to collect Supplemental Connection Charges shall cease upon the first of the following events to occur:

- (1) The lapse of twenty-five (25) years from the date of District's approval and acceptance of the Wastewater Facilities; or

- (2) At any time District no longer has the legal authority to collect these charges.

c. Nothing in this Agreement shall be interpreted to require District to allow connections to be made to the Wastewater Facilities. Connections may be denied by District under any circumstances including, but not limited to the following:

- (1) District does not have sufficient capacity to serve the proposed connection(s); or
- (2) District is precluded by law from allowing the connection(s); or
- (3) The proposed connection(s) are not in compliance with established policies and regulations of District.

3. **Reimbursement**

a. For purposes of this paragraph 3, the persons to whom reimbursement shall be made by District are referred to as "Reimbursees."

b. The following persons are Reimbursees and shall be entitled to reimbursement as provided in this paragraph 3:

- (1) Developer; and
- (2) Prior Connectors who have paid Supplemental Connection Charges.

c. Except as provided in subparagraph 3.d. below, as Supplemental Connection Charges are collected from each new Connector for each new connection, District shall credit the account of each Reimbursee with a proportionate share of the charges collected based upon the ratio which each Reimbursee's discharge entitlement, measured in SFDEs, bears to the total of all wastewater discharge entitlements, measured in SFDEs, for all Reimbursees, less District's reasonable administrative cost to make the collection and reimbursement of the Supplemental Connection Charge.

d. In the case of any prior Connector who is a Reimbursee pursuant to subparagraph 3.b. above but who, pursuant to the provisions of subparagraph 2.a. of this Agreement, has not been required by the District to pay the full Supplemental Connection Charge which otherwise should have been imposed, such a connector shall be entitled to reimbursement, but only to the extent provided in this subparagraph. In calculating such a Connector's reimbursement amount pursuant to subparagraph 3.c. above, the Connector's wastewater discharge entitlement shall be discounted in the same ratio as the amount of the Supplemental Connection Charge actually paid by the Connector bears to the Supplemental Connection Charge which the connector should have paid except for the effect of the provisions of subparagraph 2.a.

e. Payment of amounts credited will be made by District within a reasonable time

after Supplemental Connection Charges are collected.

f. In the absence of written instructions in form and substance acceptable to District, District's reimbursement obligations to any Reimbursee shall be deemed fully satisfied upon sending the reimbursement payment(s) to the Developer and, if applicable, to prior Connectors, who paid the Supplemental Connection Charge to the addresses shown for such persons in District's records. Each Reimbursee shall be responsible to inform the District of any changes. If District becomes aware that a dispute exists regarding the identity of the person to whom the payment is due, District may withhold the payment until the dispute is resolved to District's satisfaction.

A Reimbursee may assign the Reimbursee's reimbursement rights under this Agreement; provided, however, that insofar as District's rights and obligations are concerned, any such assignment shall be effective only if (1) District is provided with evidence, satisfactory to District, of the regularity and authenticity of the assignment and (2) the parties to the assignment have executed and delivered to District instruments in form and substance satisfactory to District which relieve District from any liability or obligation by reason of District's reliance upon and performance of its duties in conformity with the provisions of the assignment.

g. Interest shall not accrue on any funds collected and held for the account of persons pursuant to the provisions of this Agreement, and no person shall have a claim against District for interest on such funds; provided, however, that the provisions of this subparagraph do not preclude application of the interest factor provided for in subparagraph 1.b. above.

4. **Connectors' Approval of Agreement**

As a condition of the District's approval of any connection to the Wastewater Facilities, the District may require a Connector to execute an instrument, in form and substance acceptable to District, which evidences Connector's acknowledgment of the Terms and Conditions of this Agreement and consent to be bound thereby.

5. **Miscellaneous Provisions**

a. This Agreement constitutes the entire understanding and agreement between the parties.

b. This Agreement may not be modified or amended except by a further written agreement executed by all parties who are signatories hereto.

c. This Agreement shall be binding upon and inure to the benefit of the parties, their assigns, personal representatives and successors in interest.

d. At the option of District, the signatures of the persons executing this Agreement on behalf of the parties shall be acknowledged and the Agreement shall be recorded in the Official Records of San Mateo County.

District:

WEST BAY SANITARY DISTRICT

By: Jim P. Parione
President

Attest: David M. Knight
Secretary

Developer:

By: [Signature]
Domenic Andrighetto – 235 Shawnee Pass

By: [Signature]
Alison Krausz – 234 Shawnee Pass

By: [Signature]
Michael Scandalios – 225 Shawnee Pass

N:\BILLK\reimburs\shawneepass-agreenoclause.DOC

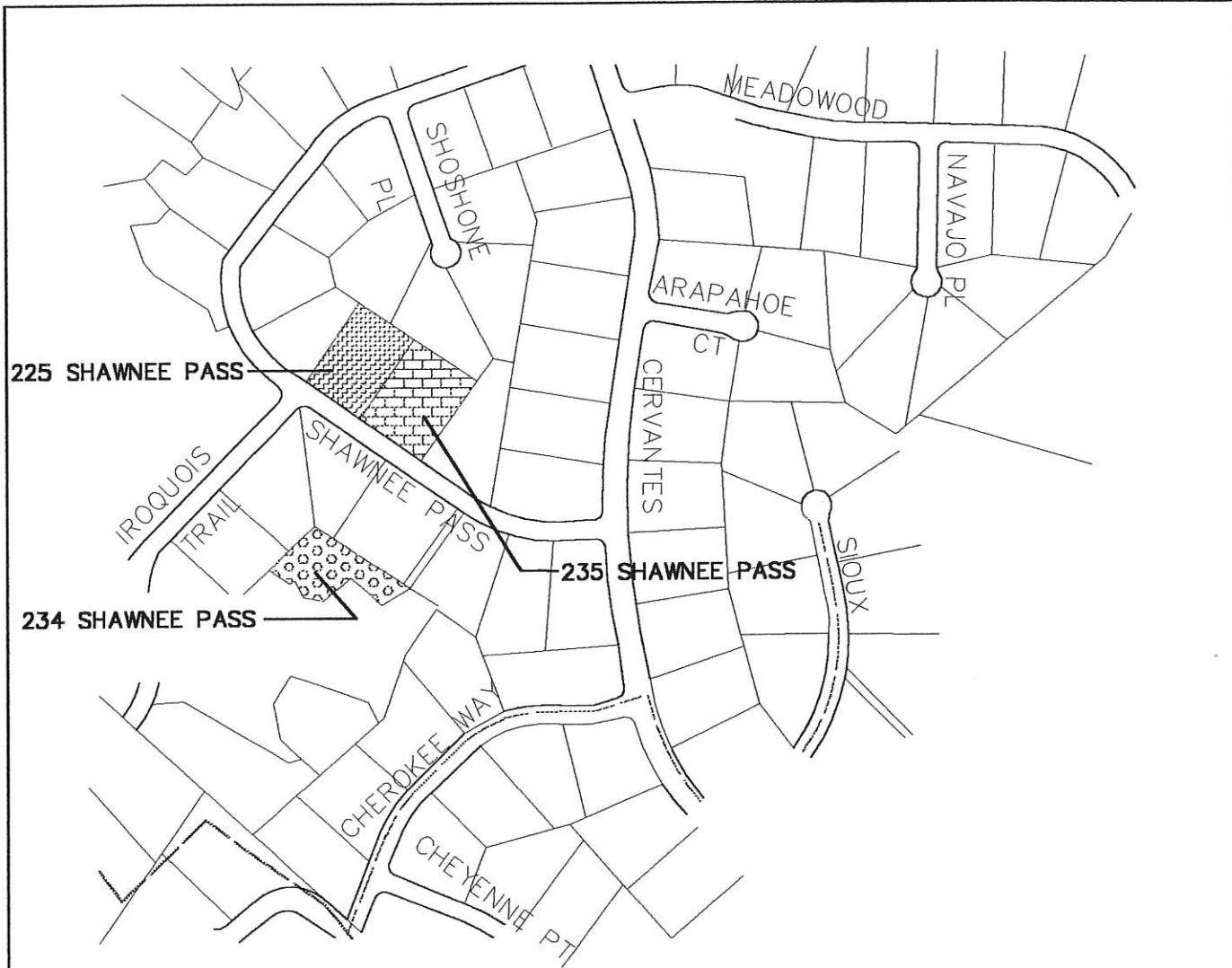

All that certain real property situate in the Town of Portola Valley, County of San Mateo, State of California, described as follows:

Lots 3 and 4 of Block 1 as shown on that certain map entitled "Tract No 806 Arrowhead Meadows No. 5, being a portion of the Rancho El Corte Madera, San Mateo County, California," filed in the office of the County Recorder of San Mateo County, State of California, on October 25, 1962 in Volume 57 of Parcel Maps at page 5 and a portion of that certain 8.0 acre tract conveyed by Deed from Dent W. MacDonough and wife to Frank Dorn Barclay, Jr. and wife, date September 2, 1958 and recorded April 1, 1959, in Book 3574, of Official Records at page 469, Records of San Mateo County, California.

WEST BAY SANITARY DISTRICT	EXHIBIT "A"
235, 234, AND 225 SHAWNEE PASS FORCEMAIN EXTENSION	

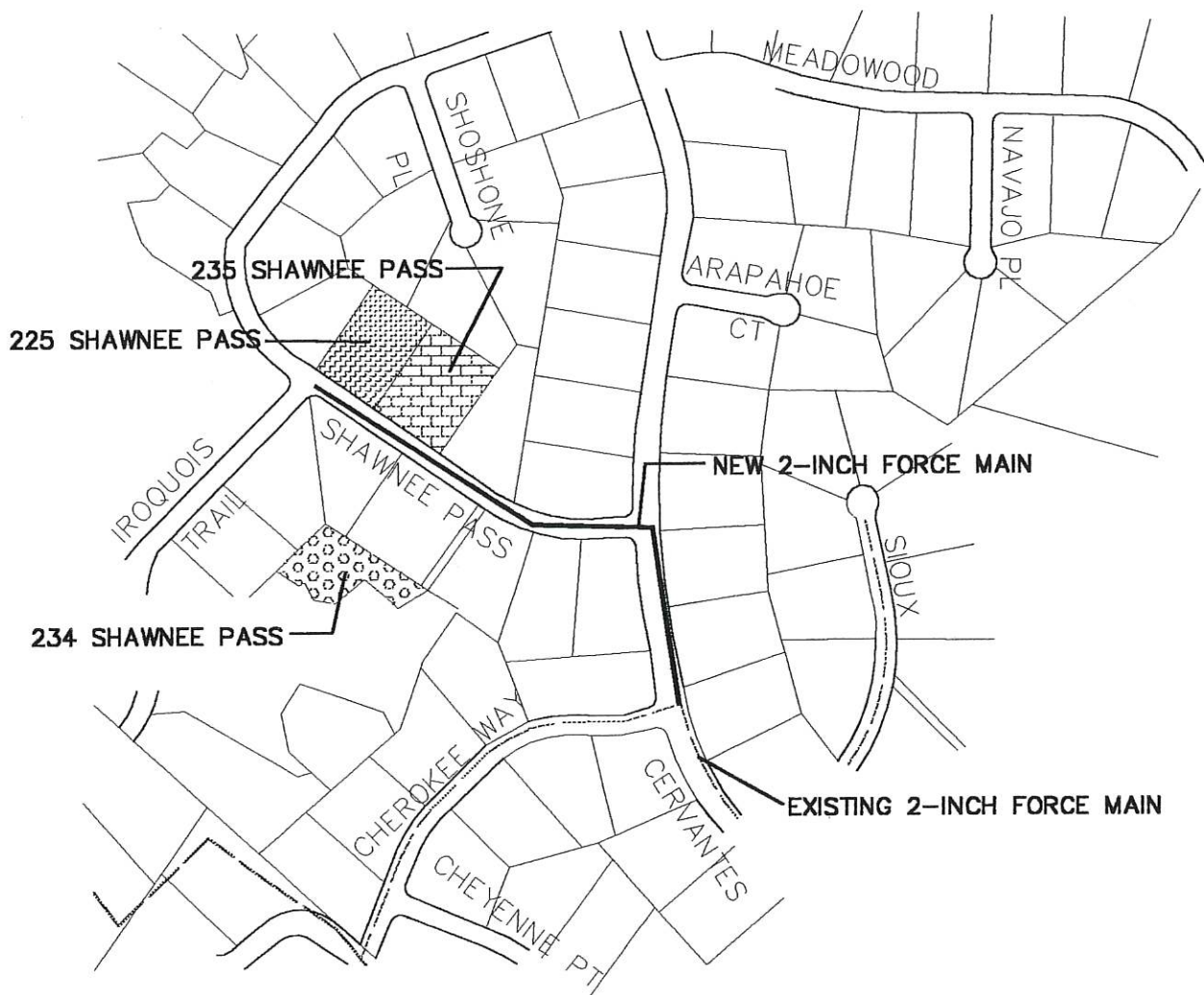

A two-inch sanitary sewer force main starting near the existing two-inch District force main at the intersection of Cherokee Way and Cervantes Road, westerly along Cervantes Road approximately 450 feet, then southwesterly along Shawnee Pass to the end of the two-inch force main extension near Lots 3 of Block 1 (225 Shawnee Pass) as shown on that certain map entitled "Tract No 806 Arrowhead Meadows No. 5, being a portion of the Rancho El Corte Madera, San Mateo County, California," filed in the office of the County Recorder of San Mateo County, State of California, on October 25, 1962 in Volume 57 of Parcel Maps at page 5.

WEST BAY SANITARY DISTRICT	EXHIBIT "B"
235, 234, AND 225 SHAWNEE PASS FORCEMAIN EXTENSION	



WEST BAY SANITARY DISTRICT AGENDA ITEM 7

To: *Board of Directors*

From: *Debra Fisher, Finance Manager*

Subject: *Consider Approving Closing of Boyce Reimbursement Agreement*

Background

On July 12, 2004 the District entered into a reimbursement agreement with Richard Boyce, Sandy Boyce, Alan Denenberg, Lauren Denenberg, Andrew Waddell, Kathy Waddell, William Thomas, Susan Thomas, Ramon Villareal, and Kelly Villareal for sewer main extension to 420, 440, 455, and 460 Cervantes Road and 130 Meadowood Drive, which was completed October 28, 2002. The District reviewed the costs and determined that \$99,990 was eligible for reimbursement and approved by the Board on July 12, 2004 by Resolution 1545 (2004).

The original terms of the agreement will be fulfilled by the District after final payments are issued for 193 Meadowood Drive and 460 Cervantes Road, connections 13 and 13.4, respectively, for the total \$99,990 eligible for reimbursement.

The District will notify all parties that, with final payments, it has fulfilled its full obligation under the Agreement and the Agreement will be closed.

Fiscal Impact

The District has issued \$89,642.34 between 2005 and 2022 to the original contract parties, with \$10,347.70 eligible reimbursement, per the agreement on the two outstanding connections, for a total of \$99,990.04 to the parties named above.

Recommendation

The Finance Manager recommends the District Board approve the closing of the reimbursement agreement with Richard Boyce, Sandy Boyce, Alan Denenberg, Lauren Denenberg, Andrew Waddell, Kathy Waddell, William Thomas, Susan Thomas, Ramon Villareal, and Kelly Villareal.

Attached: Board Resolution 1545 (2004)
Boyce Reimbursement Agreement

RESOLUTION NO. 1545 (2004)

IN THE DISTRICT BOARD OF THE WEST BAY SANITARY DISTRICT

COUNTY OF SAN MATEO, STATE OF CALIFORNIA

BE IT RESOLVED that the President and Secretary of the West Bay Sanitary District be and are hereby authorized to execute the attached Reimbursement Agreement by and between the West Bay Sanitary District ("District") and Richard Boyce, Sandy Boyce, Alan Denenberg, Lauren Denenberg, Andrew Waddell, Kathy Waddell, William Thomas, Susan Thomas, Ramon Villareal and Kelly Villareal ("Developers").

Passed and adopted by the District Board of the West Bay Sanitary District at a regular meeting thereof held on the 12th day of July 2004, by the following vote:

Ayes: CARCIONE, SHEPHERD, WALKER, LOMAX AND KNIGHT

Noes: -NONE-

Abstain: -NONE-

Absent: -NONE-

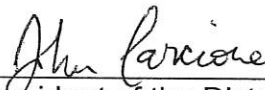

President of the District Board of the West Bay
Sanitary District of San Mateo County, State of
California

Attest:



Secretary of the District Board of the West Bay
Sanitary District of San Mateo County, State of
California

**REIMBURSEMENT AGREEMENT
LANDS OF BOYCE, DENENBERG, WADDELL,
THOMAS AND VILLAREAL
420, 440, 460, AND 455 CERVANTES ROAD
AND 130 MEADOWOOD ROAD, PORTOLA VALLEY**

This Agreement is entered into this 12TH day of JULY, 2004, by and between the WEST BAY SANITARY DISTRICT, a public agency, hereinafter referred to as "District" and RICHARD BOYCE, SANDY BOYCE, ALAN DENENBERG, LAUREN DENENBERG, ANDREW WADDELL, KATHY WADDELL, WILLIAM THOMAS, SUSAN THOMAS, RAMON VILLAREAL, AND KELLY VILLAREAL, the other persons executing this Agreement, hereinafter referred to as "Developer."

RECITALS

A. Developer pursued and completed development activities on certain real property located in the territory of District and more particularly described in Exhibit "A" attached hereto ("the Real Property") for which it has been necessary for Developer to construct and install, at Developer's expense, certain wastewater collection and transmission facilities (the "Wastewater Facilities") to serve the development. The Wastewater Facilities are more particularly described in Exhibit "B" attached hereto.

B. The Wastewater Facilities are complete and on October 28, 2002, they were accepted by District and are now public property of District. The Wastewater Facilities have the potential to serve and benefit persons in the District in addition to those persons who may occupy the Real Property.

C. Because persons other than those who may occupy the Real Property may be served and benefited by the Wastewater Facilities, the parties agree that such persons should be required to reimburse Developer for their proportionate share of Developer's cost to construct and install the Wastewater Facilities.

D. District has reviewed the costs incurred by Developer and has determined that the total sum of Ninety nine Thousand Nine Hundred Ninety Dollars (\$ 99,990.00) is eligible for reimbursement pursuant to the following Terms and Conditions of this Agreement.

In consideration of the foregoing Recitals and the following Terms and Conditions, District and Developer agree as follows:

TERMS AND CONDITIONS

1. Supplemental Connection Charge

a. In addition to the usual connection charges imposed by the District upon connection to the District's wastewater system, the District shall also impose a "Supplemental Connection Charge" for each connection to the Wastewater Facilities by any of the following persons (referred to in this Agreement as "Connectors"):

- (1) Any person, other than Developer, who makes an initial connection to the Wastewater Facilities;
- (2) Any person, other than Developer, who makes one or more additional connections to the Wastewater Facilities;
- (3) Any person, other than Developer, who increases the discharge of wastewater through an existing connection to the Wastewater Facilities if that discharge exceeds the person's authorized discharge entitlement; and
- (4) Developer, if Developer either (a) makes one or more additional connections to the Wastewater Facilities, or (b) increases the discharge of wastewater through an existing connection to the Wastewater Facilities so that the resulting discharge exceeds the Developer's authorized discharge entitlement; provided, however, that in either of the foregoing cases, the Supplemental Connection Charge otherwise payable by Developer will be waived if (a) there have been no prior connections to the Wastewater Facilities other than connections made by Developer, and (b) Developer executes an amendment to this Agreement in form and content acceptable to District which makes an appropriate adjustment in the "Cp" factor attributable to Developer.

For purposes of this Agreement, a connection includes both a connection of a building sewer to the Wastewater Facilities and a connection of an upstream sewer extension to the Wastewater Facilities.

b. Subject to the provisions of subparagraph 1.c. below, the amount of the Supplemental Connection Charge payable by each Connector shall be computed in accordance with the following formula:

$$SCC = \frac{ERC \times C_n \times (ENRC/ENRI)}{C_p + C_n}$$

Where:

SCC = The Supplemental Connection Charge to be paid by the new Connector.

ERC = The total eligible reimbursable cost specified in Recital D of this Agreement.

Cp = A factor representing the total wastewater contribution of all previous Connectors to the Wastewater Facilities measured in SFDE pursuant to subparagraph 1.d. below.

Cn = A factor representing the wastewater contribution of the new Connector to the Wastewater Facilities measured in SFDE pursuant to subparagraph 1.d. below.

ENRC = The ENR Construction Cost Index, rounded to the nearest whole number, for the month in which payment of the supplemental connection charge is made by

the new connector.

ENRI = The ENR Construction Cost Index for the month in which the Wastewater Facilities were accepted by the District. ENRI shall be 6579.

c. Under no circumstances shall the amount of the Supplemental Connection Charge payable by a Connector exceed the estimated cost of constructing wastewater facilities from the Connector's property to the point where the Wastewater Facilities constructed by Developer connect to District's system. For this purpose, the estimated cost shall be determined by District.

d. Prior to the approval of a new connection to the Wastewater Facilities, the District Manager shall determine and establish the contribution of wastewater expected to be generated by the new Connector, measured in terms of single family dwelling equivalents ("SFDE"). Each single family dwelling unit shall be assigned a factor of 1 SFDE. All other uses shall be assigned an equivalency factor which is representative of the contribution of wastewater expected to be generated by the particular use. The equivalency factor shall take into account the volume of wastewater flows expected to be produced by the Connector and any other characteristics of the Connector's wastewater which may have an impact on the Wastewater Facilities. However, in no event shall any Connector be assigned an equivalency factor of less than 1 SFDE.

e. For purposes of this Agreement the amount of Cp attributable to Developer's wastewater contribution shall be 5 SFDE.

2. Collection of Supplemental Connection Charges

a. District shall use its best efforts to collect Supplemental Connection charges from all persons who become obligated to pay them. However, District may postpone or waive, in whole or in part, collection of any such charges if, after reasonable notice and hearing, the District Board, in the exercise of reasonable discretion, makes one of the following determinations:

- (1) Acting pursuant to Health and Safety Code Section 6520.6, the District Board determines the amount is too small to justify the cost of collection; or
- (2) The District Board determines that in the interest of the public health, safety and welfare, collection of the amount is not justified; or
- (3) The District Board determines that collection of the amount would pose an undue financial hardship on the new Connector.

If such a determination is made by the District Board, the determination shall be binding, and neither Developer, Connectors or any other person shall have a claim against District by reason of District's failure to collect any amount which is the subject of such a determination.

b. District's obligation to collect Supplemental Connection Charges shall cease upon the first of the following events to occur:

- (1) The lapse of twenty-five (25) years from the date of District's approval and acceptance of the Wastewater Facilities; or
- (2) At any time District no longer has the legal authority to collect these charges.

c. Nothing in this Agreement shall be interpreted to require District to allow connections to be made to the Wastewater Facilities. Connections may be denied by District under any circumstances including, but not limited to the following:

- (1) District does not have sufficient capacity to serve the proposed connection(s); or
- (2) District is precluded by law from allowing the connection(s); or
- (3) The proposed connection(s) are not in compliance with established policies and regulations of District.

3. **Reimbursement**

a. For purposes of this paragraph 3, the persons to whom reimbursement shall be made by District are referred to as "Reimbursees."

b. The following persons are Reimbursees and shall be entitled to reimbursement as provided in this paragraph 3:

- (1) Developer; and
- (2) Prior Connectors who have paid Supplemental Connection Charges.

c. Except as provided in subparagraph 3.d. below, as Supplemental Connection Charges are collected from each new Connector for each new connection, District shall credit the account of each Reimbursees with a proportionate share of the charges collected based upon the ratio which each Reimbursees's discharge entitlement, measured in SFDEs, bears to the total of all wastewater discharge entitlements, measured in SFDEs, for all Reimbursees, less District's reasonable administrative cost to make the collection and reimbursement of the Supplemental Connection Charge.

d. In the case of any prior Connector who is a Reimbursees pursuant to subparagraph 3.b. above but who, pursuant to the provisions of subparagraph 2.a. of this Agreement, has not been required by the District to pay the full Supplemental Connection Charge which otherwise should have been imposed, such a connector shall be entitled to reimbursement, but only to the extent provided in this subparagraph. In calculating such a Connector's reimbursement amount pursuant to subparagraph 3.c. above, the Connector's wastewater discharge entitlement shall be discounted in the same ratio as

the amount of the Supplemental Connection Charge actually paid by the Connector bears to the Supplemental Connection Charge which the connector should have paid except for the effect of the provisions of subparagraph 2.a.

e. Payment of amounts credited will be made by District within a reasonable time after Supplemental Connection Charges are collected

f. In the absence of written instructions in form and substance acceptable to District, District's reimbursement obligations to any Reimbursee shall be deemed fully satisfied upon sending the reimbursement payment(s) to the Developer and, if applicable, to prior Connectors, who paid the Supplemental Connection Charge to the addresses shown for such persons in District's records. Each Reimbursee shall be responsible to inform the District of any changes. If District becomes aware that a dispute exists regarding the identity of the person to whom the payment is due, District may withhold the payment until the dispute is resolved to District's satisfaction.

A Reimbursee may assign the Reimbursee's reimbursement rights under this Agreement; provided, however, that insofar as District's rights and obligations are concerned, any such assignment shall be effective only if (1) District is provided with evidence, satisfactory to District, of the regularity and authenticity of the assignment and (2) the parties to the assignment have executed and delivered to District instruments in form and substance satisfactory to District which relieve District from any liability or obligation by reason of District's reliance upon and performance of its duties in conformity with the provisions of the assignment.

g. Interest shall not accrue on any funds collected and held for the account of persons pursuant to the provisions of this Agreement, and no person shall have a claim against District for interest on such funds; provided, however, that the provisions of this subparagraph do not preclude application of the interest factor provided for in subparagraph 1.b. above.

4. **Connectors' Approval of Agreement**

As a condition of the District's approval of any connection to the Wastewater Facilities, the District may require a Connector to execute an instrument, in form and substance acceptable to District, which evidences Connector's acknowledgment of the Terms and Conditions of this Agreement and consent to be bound thereby.

5. **Miscellaneous Provisions**

a. This Agreement constitutes the entire understanding and agreement between the parties.

b. This Agreement may not be modified or amended except by a further written agreement executed by all parties who are signatories hereto.

c. This Agreement shall be binding upon and inure to the benefit of the parties, their assigns, personal representatives and successors in interest.

d. At the option of District, the signatures of the persons executing this Agreement on behalf of the parties shall be acknowledged and the Agreement shall be recorded in the Official Records of San Mateo County.

District:

WEST BAY SANITARY DISTRICT

By: John Percione
President

Attest: David A. Walker
Secretary

Developer:

By: Richard Boyce
Richard Boyce - 420 Cervantes Road

By: Sandy Boyce
Sandy Boyce - 420 Cervantes Road

By: Alan Denenberg
Alan Denenberg - 440 Cervantes Road

By: Lauren Denenberg
Lauren Denenberg - 440 Cervantes Road

By: Andrew Waddell
Andrew Waddell - 460 Cervantes Road

By: Kathy Waddell
Kathy Waddell - 460 Cervantes Road

By: William Thomas
William Thomas - 455 Cervantes Road

By: Susan Thomas
Susan Thomas - 455 Cervantes Road

By: Ramon Villareal
Ramon Villareal - 130 Meadowood Drive

By: Kelly Villareal
Kelly Villareal - 130 Meadowood Drive

N:\BILLK\reimburs\shawneepass-agreenoclause.DOC

All that certain real property situate in the Town of Portola Valley, County of San Mateo, State of California, described as follows:

Lot 4 of Block 3 as shown on that certain map entitled "Tract No 761 Arrowhead Meadows Unit 2, being a portion of the Rancho El Corte Madera, San Mateo County, California," filed in the office of the County Recorder of San Mateo County, State of California, on May 29, 1958 in Volume 48 at pages 48 and 49; and Lots 22, 26, and 27 of Block 1, and Lot 6 of Block 4 as shown on that certain map entitled "Tract No 774 Arrowhead Meadows No. 4, being a portion of the Rancho El Corte Madera, San Mateo County, California," filed in the office of the County Recorder of San Mateo County, State of California, on March 17, 1959 in Volume 50 at pages 45 to 48.

CONSTRUCTED 2-INCH FORCE MAIN

EXISTING FORCE MAIN

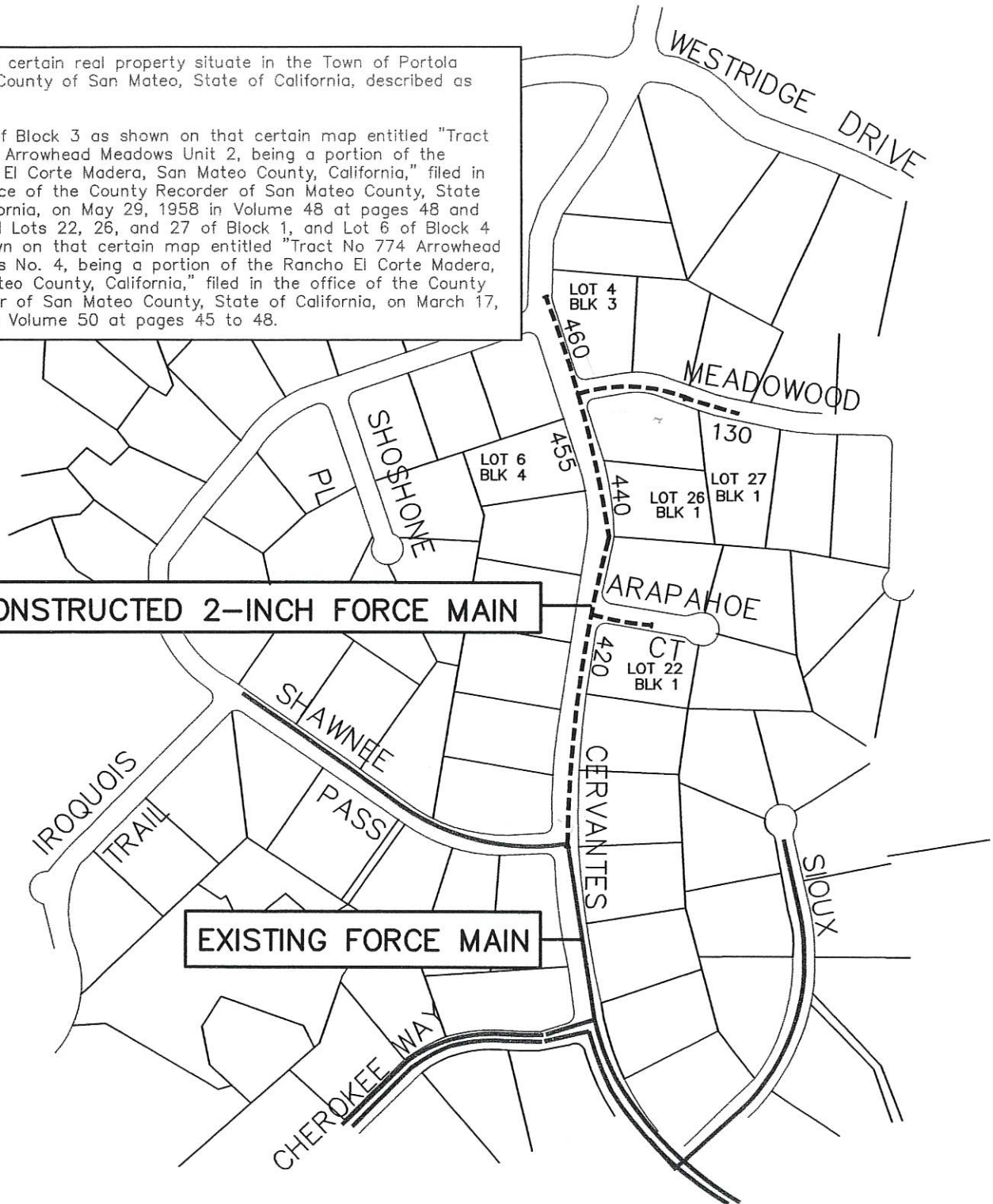

WEST BAY SANITARY DISTRICT
 420, 440, 455, AND 460 CERVANTES ROAD
 AND 130 MEADOWOOD DRIVE FORCE MAIN PROJECT

EXHIBIT 'A'

WBSD1

A two-inch sanitary sewer force main starting near the existing two-inch District force main at the first intersection of Shawnee Pass and Cervantes Road (closest to Cherokee Way), westerly along Cervantes Road approximately 1,300 feet to the second intersection of Shawnee Pass and Cervantes Road near Lot 4 of Block 3 (460 Cervantes Road) as shown on that certain map entitled "Tract No 761 Arrowhead Meadows Unit 2, being a portion of the Rancho El Corte Madera, San Mateo County, California," filed in the office of the County Recorder of San Mateo County, State of California, on May 29, 1958 in Volume 48 at pages 48 and 49, also extending the 2-inch sanitary sewer force main northerly from the intersection of Cervantes Road and Arapahoe Court approximately 200 feet near Lot 22 of Block 1 (420 Cervantes Road) and from the intersection of Cervantes Road and Meadowood Drive approximately 400 feet near Lot 27 of Block 1 (130 Meadowood Drive) as shown on that certain map entitled "Tract No 774 Arrowhead Meadows No. 4, being a portion of the Rancho El Corte Madera, San Mateo County, California," filed in the office of the County Recorder of San Mateo County, State of California, on March 17, 1959 in Volume 50 at pages 45 to 48.

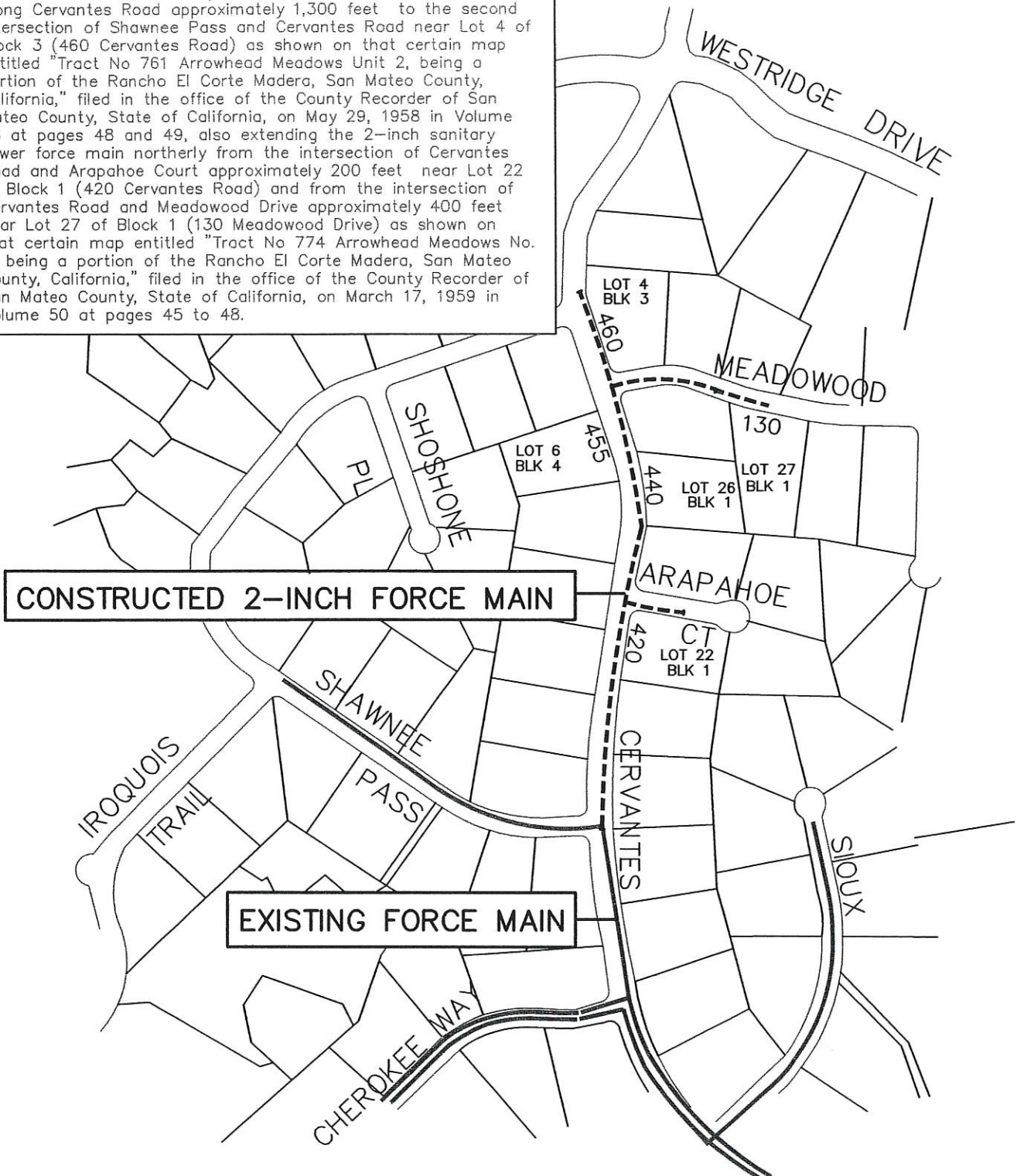

WEST BAY SANITARY DISTRICT
 420, 440, 455, AND 460 CERVANTES ROAD
 AND 130 MEADOWOOD DRIVE FORCE MAIN PROJECT

EXHIBIT 'B'

WBS01



**WEST BAY SANITARY
DISTRICT AGENDA ITEM 8**

To: Board of Directors

From: Sergio Ramirez, General Manager

**Subject: Discussion and Direction on the West Bay and Sharon Heights
Recycled Water Facility**

A discussion will be held on the Sharon Heights Recycled Water Facility and other events related to the recycled water plant. The Board will have opportunity to provide direction to staff and legal counsel.

Recycled Water Facility Production Data:

2020	Treated	Delivered
August	8.8MG	8.2MG
September	8.2MG	5.1MG
October	7.4MG	4.5MG
November	5MG	1.4MG
December	4.7MG	.55MG
2021	Treated	Delivered
January	4.8MG	.23MG
February	4.4MG	.13MG
March	5.9MG	1.8MG
April	8.5MG	7.6MG
May	9.3.MG	8.2MG
June	9.8MG	8.7MG
July	9.5MG	9.1MG
August	9.4MG	9.0MG
September	9.1MG	6.9MG*
October	7.6MG	2.6MG**
November	5.2MG	0
December	4.7MG	0

Report to the District Board for the Regular Meeting of April 12, 2023

2022	Treated	Delivered
January	4.4MG	97,000 gallons
February	4.4MG	1.5MG
March	6.6MG	3.5MG
April	7.6MG	3.8MG
May	9.2MG	7.4MG
June	9.8MG	8.7MG
July	9.6MG	8.1MG
August	9.2MG	8.1MG
September	8.6MG	6.7MG
October	7.9MG	4.6MG
November	5.9MG	310,000 gallons
December	5.4MG	154,690 gallons

2023	Treated	Delivered
January	5MG	0 gallons
February	3.3MG	0 gallons
March	3.5MG	0 gallons

* Sharon Heights substantially tapered off their water usage for September which is the reason for the large discrepancy between treated and delivered.

** Treatment was reduced in the second half of the month. Rain in late October and an irrigation equipment malfunctions caused water delivery to decrease.

The following is a disclosure statement required for any document, written report or brochure prepared in whole or in part pursuant to the Finance Agreement with the State Water Resources Control Board for the West Bay Sanitary District Recycled Water Project - Sharon Heights: Funding for this project has been provided in full or in part through an agreement with the State Water Resources Control Board. California's Clean Water State Revolving Fund is capitalized through a variety of funding sources, including grants from the United States Environmental Protection Agency and state bond proceeds. The contents of this document do not necessarily reflect the views and policies of the foregoing, nor does mention of trade names or commercial products constitute endorsement or recommendation for use.



**WEST BAY SANITARY
DISTRICT AGENDA ITEM 9**

To: Board of Directors

From: Sergio Ramirez, General Manager

**Subject: Discussion and Direction on the Bayfront Recycled Water Project
and Status Update**

A discussion will be held on the District's Bayfront Recycled Water Projects and other events related to the recycled water projects including financing, environmental review, design/build issues and grant applications.

The Board will have opportunity to provide direction to staff and general counsel.

THIS PAGE LEFT INTENTIONALLY BLANK



**WEST BAY SANITARY
DISTRICT AGENDA ITEM 10**

To:*Board of Directors*

From:*Sergio Ramirez, General Manager*

Subject:*Report and Discussion on South Bayside Waste Management
Authority (SBWMA)*

The District's representative to South Bayside Waste Management Authority (SBWMA), President Fran Dehn, will report on any pertinent items regarding SBWMA business.

THIS PAGE LEFT INTENTIONALLY BLANK



**WEST BAY SANITARY
DISTRICT AGENDA ITEM 11**

To: Board of Directors

From: Sergio Ramirez, General Manager

**Subject: Report and Discussion on Silicon Valley Clean Water (SVCW)
Plant**

The District's representative to Silicon Valley Clean Water (SVCW), Commissioner George Otte, will report on pertinent items regarding SVCW Operations, CIP and Finance.

Report to the District Board for the Regular Meeting of April 12, 2023

THIS PAGE LEFT INTENTIONALLY BLANK



WEST BAY SANITARY DISTRICT AGENDA ITEM 13

To: *Board of Directors*

From: *Sergio Ramirez, General Manager*

Subject: *Consider Approving a Deed of Easement between Las Lomas Elementary School District and West Bay Sanitary District for the Avy Altschul Pump Station*

Background

The District requires an easement to construct the Avy Altschul Pump Station in Menlo Park which will supply additional wastewater flow to the West Bay-Sharon Heights Golf and County Club Recycled Water Facility. The easement includes construction and maintenance ingress and egress to the site from Altschul Ave.

Analysis

An appraisal was conducted at the request of the Las Lomas Elementary School District. The appraised value was \$49,000.00. The appraisal was performed by J Kaeuper & Company. The District's General Counsel and the School District's Attorney then agreed on the terms and language of the grant of easement.

Fiscal Impact

A consideration of \$49,000.00 was considered for the grant of easement based on the J Kaeuper & Company appraisal. The easement will be funded in part or entirely by the State Revolving Fund Loan and Grant. The SRF loan will be paid back by Sharon Heights Golf and Country Club.

Recommendation

The General Manager recommends the Board adopt the attached Resolution accepting the Deed of Easement.

Attachments: Resolution ____ (2023), Grant Deed of Easement, Purchase Agreement

RESOLUTION NO. _____ (2023)

IN THE DISTRICT BOARD OF THE WEST BAY SANITARY DISTRICT

COUNTY OF SAN MATEO, STATE OF CALIFORNIA

BE IT RESOLVED that the President and Secretary of the West Bay Sanitary District be and are hereby authorized to accept the attached Grant Deed of Easement by and between the following parties:

Las Lomas Elementary School District and West Bay Sanitary District

BE IT FURTHER RESOLVED that the General Manager is hereby directed to place the same on record.

Passed and adopted by the District Board of the West Bay Sanitary District at a regular meeting thereof held on the 12th day of April, 2023, by the following vote:

Ayes:

Noes:

Abstain:

Absent:

President of the District Board of the West
Bay Sanitary District of San Mateo County,
State of California

Attest:

Secretary of the District Board of the
West Bay Sanitary District of San Mateo
County, State of California

RECORDING REQUESTED BY:
WEST BAY SANITARY DISTRICT

WHEN RECORDED MAIL TO:
WEST BAY SANITARY DISTRICT
500 LAUREL STREET
MENLO PARK, CA 94025

Title Order No. N/A
Escrow No. N/A
Parcel No.

GRANT DEED OF EASEMENT

THE UNDERSIGNED GRANTOR(S) DECLARE(S):

- | | | |
|---|---|------------------------------|
| DOCUMENTARY TRANSFER TAX is \$0 | CITY TAX is \$0 | DEED TO PUBLIC AGENCY |
| <input type="checkbox"/> computed on the full value of the property conveyed, or | | |
| <input type="checkbox"/> computed on full value less value of liens or encumbrances remaining at the time of sale, | | |
| <input type="checkbox"/> this is a conveyance of an easement and the consideration and value is less than \$100, R & T 11911 & R&T 11922. | | |
| <input type="checkbox"/> Unincorporated area of San Mateo County | <input type="checkbox"/> City/Town of _____ | |

FOR GOOD AND VALUABLE CONSIDERATION, receipt of which is hereby acknowledged:

Las Lomas Elementary School District, a public school district formed and existing under the laws of the State of California (hereinafter sometimes referred to as the "Grantor"),

Hereby GRANT(S) to:

West Bay Sanitary District, a special district organized and existing under the Sanitary District Act of 1923 (Cal. Health & Safety Code § 6400 et seq.) ("West Bay"):

A perpetual easement to construct, install, maintain, use, repair, remove, and replace pumps, a pipeline, fittings, electrical, and other facilities necessary for the operation of a wastewater pump station in the area within the real property in the Menlo Park, County of San Mateo, State of California; more particularly described in Exhibit "A" and "B", attached hereto, and by this reference incorporated herein (the "Easement Area"), under the following terms and conditions:

1. West Bay, its employees and agents shall have the right to enter upon the Easement Area at any and all times with such tools and equipment as may be necessary or convenient for the exercise of the rights herein granted to West Bay provided, however, that absent exigent circumstances, West Bay shall coordinate with District to ensure that maintenance activities avoid disruption of District operations. For example, maintenance that involves activities that generate noise, dust, fumes or other impacts sufficient to disrupt classroom instruction shall, to the full extent feasible, be performed after hours or while school is not in session.
2. No building or structure of any kind shall be constructed upon the Easement Area, and should a building or structure be erected in violation of this provision, West Bay and its successors and assigns may nevertheless exercise all rights herein granted and shall have the right to remove, or cause Grantor to remove, any building or structure that may be erected upon the Easement Area. West Bay shall not be held liable in any manner whatsoever for any damages thereby incurred, nor shall West Bay have any obligation to replace any structure that may be removed from the Easement Area.
3. West Bay shall, at all times, maintain the Easement Area and all equipment in the Easement Area in good condition and repair, and shall indemnify, defend and hold District harmless from any and all liability arising from West Bay's use of the Easement Area and shall, at all times, maintain adequate and appropriate policies of liability insurance or equivalent liability protection, which policies or protection shall be subject to District's review and approval, which approval shall not be unreasonably

withheld. If West Bay fails to maintain the Easement Area in good condition and repair, the Grantor shall, after reasonable written notice to West Bay, be entitled to make any necessary corrections to site conditions and to invoice West Bay for the related costs.

4. The easement granted herein shall automatically terminate in the event that West Bay decommissions or discontinues the use of the facilities to be constructed within the Easement Area and, in that event West Bay shall, upon request by District, promptly execute a quitclaim or other suitable documentation evidencing such termination, remove such facilities, and restore the easement area, to the extent reasonably feasible, to its pre-existing condition.

This grant of easement shall be binding upon and shall inure to the benefit of the respective administrators, executors, personal representatives, successors and assigns of the parties hereto.

LEGAL DESCRIPTION ATTACHED HERETO AS EXHIBITS "A" AND "B" MADE A PART HEREOF
Also Known As: 2245 Avy Avenue, Menlo Park, CA 94025 (portion)
Assessor's Parcel Number: 074-170-530 (portion)

IN WITNESS WHEREOF, the Parties have executed Grant Deed of Easement, effective as of the date of recordation.

GRANTOR: LAS LOMITAS ELEMENTARY SCHOOL DISTRICT

Date: _____
[insert name]
[insert title]

GRANTEE: WEST BAY SANITARY DISTRICT

Date: _____ By: _____
Sergio Ramirez
General Manager

[attach California All-Purpose Acknowledgement]

Exhibit A

**LEGAL DESCRIPTION
SANITARY SEWER EASEMENT**

All that certain real property situated in the City of Menlo Park County of San Mateo, State of California, described as follows:

COMMENCING at the northerly-most corner of Parcel 1-A of the Lands of the Las Lomas Elementary School District, as said lands are described in a Deed recorded in Volume 3886 of Official Records of San Mateo County at Page 313 (4784-T), thence leaving said corner South 56°28'40.50" East 111.61 feet; thence South 33°31'19.50" West 30.00 feet to the **TRUE POINT OF BEGINNING**; thence, proceeding counterclockwise the following courses and distances:
South 33°31'19.50" West 14.33 feet;
thence North 33°37'15" West 36.90 feet along the northerly line of an existing 5-foot wide Sanitary Sewer Easement recorded December 11, 1962, in Book 4351, Page 93, Official Records of San Mateo County;
thence South 56°28'40.50" East 34.00 feet to the True Point of Beginning.

Containing 243.65 square feet more or less.

6/6//2022

FREYER & LAURETA, INC.

Exhibit B

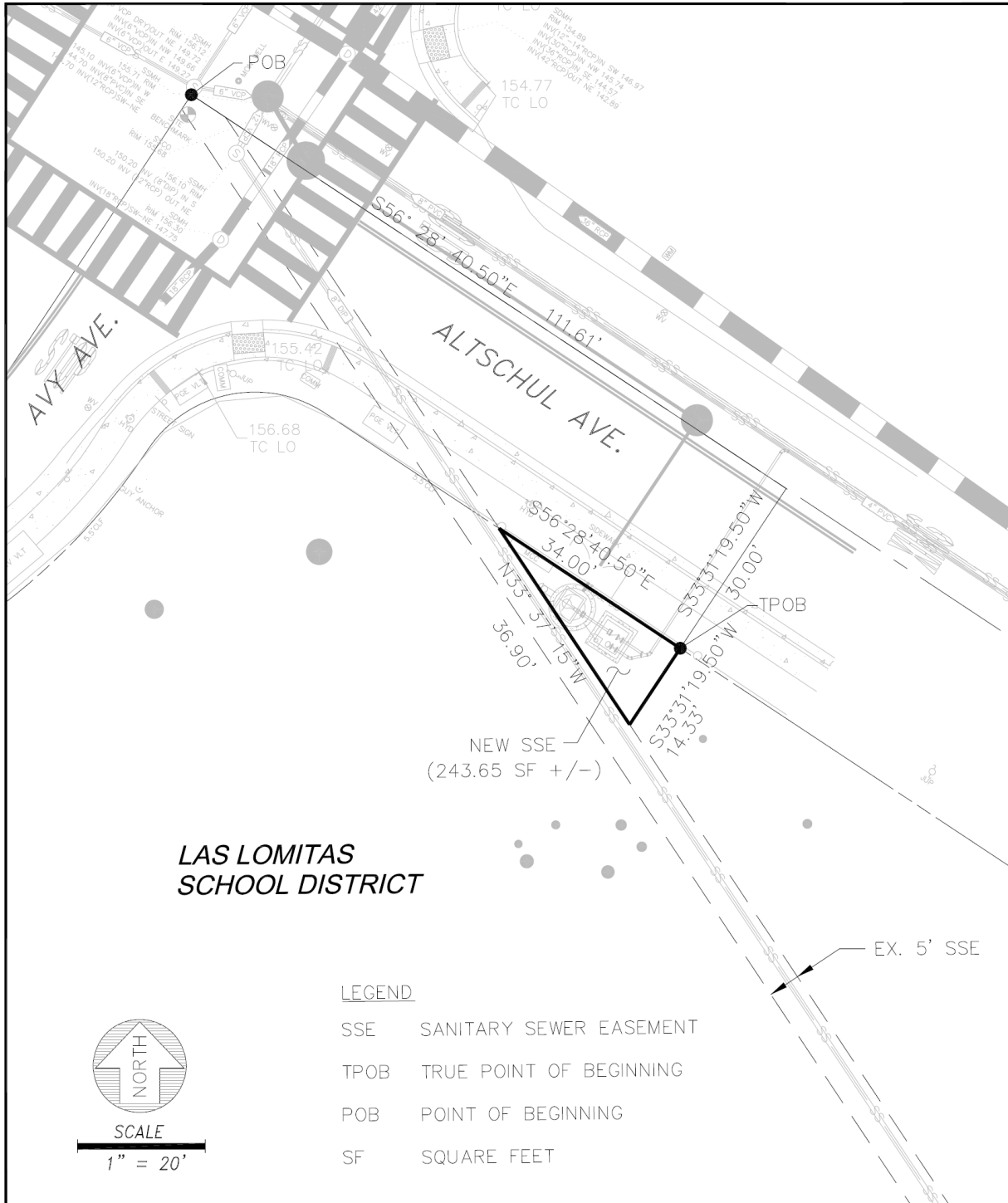

**LAS LOMITAS
SCHOOL DISTRICT**

LEGEND

- SSE SANITARY SEWER EASEMENT
- TPOB TRUE POINT OF BEGINNING
- POB POINT OF BEGINNING
- SF SQUARE FEET



SCALE
1" = 20'



CIVIL ENGINEERS • SURVEYORS • CONSTRUCTION MANAGERS
150 Executive Park Blvd • Suite 4200 • San Francisco, CA 94134
(415) 534-7070 • www.freyerlaureta.com

PLAT TO ACCOMPANY LEGAL DESCRIPTION
NEW SANITARY SEWER EASEMENT
LAS LOMITAS ELEMENTARY SCHOOL DISTRICT
MENLO PARK, CA

6/06/22

REAL PROPERTY PURCHASE AGREEMENT

This Real Property Purchase Agreement (“Agreement”) is entered into by and between the LAS LOMITAS ELEMENTARY SCHOOL DISTRICT, a public elementary school district formed and existing under the laws of the State of California (“District” or “Seller”) and WEST BAY SANITARY DISTRICT, a special district organized and existing under the Sanitary District Act of 1923 (“West Bay” or “Buyer”), as of the latest date of execution set forth on the signature page below (the “**Effective Date**”). The District and West Bay may each be referred to from time to time in this Agreement as a “Party,” and, collectively, as the “Parties.”

RECITALS

This Agreement is entered into with reference to the following facts:

A. Seller is the owner in fee simple of real property commonly known as 1101 Altschul Avenue, Menlo Park, California 94024, identified as Assessor’s Parcel Nos. 074-170-430, 074-170-530, 074-184-100 and 074-190-030 in the Records of the San Mateo County Assessor (the “**Subject Property**”).

B. Buyer seeks to acquire an exclusive easement (the “Easement”) in a portion of the Subject Property to construct and operate the Avy/Altschul Pump Station Project (“**Project**”), as more particularly shown and described in the Easement Deed attached hereto and incorporated herein by reference as Exhibit A to this Agreement.

C. AGREEMENT

NOW THEREFORE, in consideration of the foregoing Recitals, which are incorporated herein by this reference, and other valuable consideration, the receipt of which is hereby acknowledged, the Parties hereto agree as follows:

1. Purchase Price. The total purchase price (the “**Purchase Price**”) to be paid by Buyer to Seller for the Easement shall be Forty-Nine Thousand Dollars (\$49,000.00) to be deposited by Buyer into escrow within five (5) business days of the Effective Date. The Parties acknowledge and agree that the total compensation to be paid by Buyer for the Easement is the Purchase Price, which amount is the full and complete acquisition cost based upon the fair market value of the Easement as determined by an independent appraiser. Buyer shall have no obligation to Seller under the California Relocation Assistance and Real Property Acquisition statutes and guidelines due to the acquisition of the Easement under this Agreement.

2. Conditions Precedent. Buyer's obligation to perform under this Agreement shall be subject to Seller’s performance under this Agreement, and satisfaction or waiver by Buyer of the following conditions:

A. Title. As soon as practicable following the opening of Escrow, the Escrow Holder shall cause to be issued a Preliminary Report regarding the Property, which Preliminary

Report shall be prepared at Buyer's expense. Buyer shall have ten (10) days from the date of receipt of the Preliminary Report, and copies of all recorded Exceptions to title set forth in this Preliminary Report, within which to review and approve the Exceptions to title. Should Buyer disapprove of any Exception to title described in this Preliminary Report, Buyer shall, within this ten (10)-day period, give written notice to Seller of Buyer's disapproval of any Exception therein. Failure to so notify Seller within this ten (10)-day period, shall constitute approval and a waiver by Buyer of this condition. Should Buyer give timely written notice to Seller of their disapproval of any such Exception, Seller shall have ten (10) days from receipt of Buyer's notice within which to notify Buyer in writing of Seller's intent to remove such Exception(s) during the pendency of escrow. Seller's refusal to so agree, or Seller's failure to notify Buyer within this ten (10)-day period of Seller's agreement to remove the disapproved Exception(s) prior to the Close of Escrow, shall give Buyer the right to terminate this Agreement by giving written notice to Seller within ten (10) days following the date of receipt of Seller's refusal or from the end of the ten (10)-day period within which Seller is to so notify Buyer, whichever is earlier. Failure of Buyer to give timely written notice of termination shall constitute a waiver of this right to terminate this Agreement.

2. Warranties and Representations of Seller. Seller hereby represents and warrants to Buyer the following, it being expressly understood and agreed that all such representations and warranties are to be true and correct as of the Close of Escrow and shall survive the Close of Escrow:

A. That Seller is the sole owner of the Subject Property clear of all liens, claims, encumbrances, encroachments from adjacent properties, encroachments by improvements on the Subject Property or rights of way of any nature, other than those that may appear on the title commitment.

B. Neither this Agreement nor anything provided to be done hereunder including the transfer of the Easement to Buyer, violates or shall violate any contract, agreement or instrument to which Seller is a party, or which affects the Easement, and the sale of the Easement herein contemplated does not require the consent of any party not a signatory hereto.

C. Seller has no knowledge of any pending, threatened, or potential litigation, action or proceeding against Seller or any other Party before any court or administrative tribunal, which is in any way related to the Easement.

3. Escrow. The parties shall establish an Escrow to accommodate the transaction contemplated by this Agreement. For purposes of this Agreement, Opening of Escrow shall mean the date on which the Escrow Holder shall have received a fully executed original of this Agreement from the parties. Buyer shall bear all costs related to the Escrow.

A. Deed. Attached hereto as Exhibit A is a copy of the form of Easement Deed to be executed by Seller as materially set forth in Exhibit A, in favor of Buyer, to be recorded by Escrow Holder upon the Close of Escrow. Seller shall deposit a fully and duly executed form of Easement Deed into Escrow before the Close of Escrow, as defined herein.

B. Close of Escrow. The Close of Escrow shall mean the date upon which the Deeds are recorded in the Official Records of the County of San Mateo. The parties shall seek to have the Close of Escrow occur within thirty (30) days from the Effective Date of this Agreement; however, the Close of Escrow shall not be more than forty-five (45) days from the Effective Date of this Agreement (the “**Closing Date**”). If a delay in the Closing Date is due to the default of a party, the non-defaulting party, at their election, may extend the Closing Date to allow the defaulting party additional time to cure the default.

C. Title Insurance. Buyer shall receive a CLTA Standard Coverage policy unless Buyer has chosen another policy and instructed Escrow Holder in writing of the policy chosen. Any title insurance premium for title insurance issued to Buyer shall be paid in full by Buyer.

D. Property Taxes and Special Assessments. From and after the Closing Date, Buyer shall be solely responsible for the payment of any and all Property Taxes imposed and shall assume any non-delinquent installments due on any assessment bonds imposed on the Property. Seller shall be solely responsible for any installments due on any assessment bonds due prior to the Closing Date.

E. Costs. Buyer shall pay for the cost of the ALTA Owner’s Standard Coverage Policy of Title Insurance, the Escrow fees and Escrow Holder’s customary out-of-pocket expenses for messenger services, long distance telephone, etc. Buyer shall pay for recording the Deeds and any documentary or other local transfer taxes, and any other recording fees. If the Escrow shall fail to close through no fault of either party, Buyer shall pay the Escrow cancellation charges.

F. Authorization to Record Documents and Disburse Funds. Escrow Holder is hereby authorized to record the Easement Deed and disburse the Purchase Price called for hereunder upon the Close of Escrow, provided each of the following conditions has then been fulfilled:

- i. Escrow Holder issues in favor of Buyer the Title Policy, showing the Subject Property vested in Seller;
- ii. Seller shall have deposited in Escrow the Escrow Deed required in Section 5(A); and
- iii. Buyer shall have deposited in escrow the Purchase Price.

G. Further Instructions. Each party agrees to execute such other and further Escrow instructions as may be necessary or proper in order to consummate the transaction contemplated by this Agreement.

4. License to Enter. Seller hereby grants to Buyer and Buyer’s authorized agents, contractors, and consultants a license to enter upon the Subject Property for the purpose of making inspections and other examinations of the Easement during the Escrow period including, but not limited to, the right to perform soil and geological tests of that site and an environmental site assessment thereof, subject to the following:

A. Buyer shall give Seller at least 72-hour telephone notice before entering Seller's Land, which notice requires Buyer to include the name of the company, the person and their purpose for access to the Subject Property.

B. Buyer shall provide Seller with a copy of any soil, geological test and environmental site assessment of the Subject Property.

C. Buyer does hereby indemnify and forever save Seller, Seller's heirs, successors and assigns, and the Subject Property, free and harmless from and against any and all liability, loss, damages and costs and expenses, demands, causes of action, claims or judgments, whether or not arising from or occurring out of any damage to the Subject Property as a result of any accident or other occurrence at Subject Property which is in any way connected with Buyer's inspections or non-permanent improvements involving entrance onto the Subject Property pursuant to this Section. If Buyer fails to acquire the Easement due to Buyer's default, this license shall terminate upon the termination of Buyer's right to purchase the Easement. In such event, Buyer shall remove or cause to be removed all Buyer's personal property, facilities, tools and equipment from the Subject Property.

5. AS-IS Clause. Buyer acknowledges that it is familiar with all aspects relating to the Easement. Buyer specifically acknowledges that this Agreement gives to Buyer a right to purchase the Property on an "AS IS WITH ALL FAULTS" basis and that, except as otherwise may be provided in this Agreement, Buyer is not relying on any representations or warranties of any kind whatsoever, express or implied, from Seller or its agents or employees, as to any matters concerning the Easement area, including without limitation: (a) the quality, nature, adequacy and physical condition of soils, geology and any groundwater; (b) the development potential of the Easement area, and the Easement area's use, habitability, merchantability, fitness, suitability, value or adequacy for any particular purpose; and (c) the presence or release of hazardous or toxic materials, as those terms are defined in any local, state or federal statute or regulation, including, without limitation, petroleum and petroleum by products, on, under, about or from the Easement area or the adjoining or neighboring property.

6. Notices. All notices and other communications under this Agreement shall be in writing and shall be deemed to have been duly given on the date of service if served personally on the party to whom notice is to be given, one business day following delivery to a reputable overnight courier for next day delivery, the third day after mailing if mailed to the party to whom notice is to be given, by first class mail, registered or certified, postage prepaid, or on the date a fax confirmation sheet indicates transmission by fax has been received. All such notices and other communications shall be addressed to the parties as follows:

SELLER:

Las Lomas Elementary School District
1011 Altschul Avenue
Menlo Park, CA 94025
Attn: Superintendent and Chief Business Official
Tel: (650) 854-6311

Email: bpolito@llesd.org and mchan@llesd.org

With copy to:

Office of the San Mateo County Attorney
Attn: County Attorney
400 County Center, 6th Floor
Redwood City, CA 94063

Tel: (650) 363-4757

Email: jnibbelin@smcgov.org

BUYER:

West Bay Sanitary District
500 Laurel Street
Menlo Park, CA 94025
Attn : Sergio Ramirez, General Manager
Tel : (650)321-0384
Email : SRamirez@westbaysanitary.org

With copy to:

Escrow Holder
[insert]

Any party may change its address for purposes of this paragraph by giving the other parties written notice of the new address in the manner set forth above.

7. Applicable Law. This Agreement shall be construed and interpreted under, and governed and enforced according, to the laws of the State of California. Any judicial actions brought pursuant to this Agreement shall be filed in San Mateo County Superior Court.

8. Entire Agreement. This Agreement supersedes any prior agreement, oral or written, and together with the Exhibits hereto and any agreements delivered pursuant hereto, contains the entire agreement between the parties on the subject matter hereof. No subsequent agreement, representation or promise made by either party hereto, or by or to any employee, officer, agent or representative of either party, shall be of any effect unless it is in writing and executed by the party to be bound thereby. No person is authorized to make, and by execution hereof, the parties acknowledge that no person has made, any representation, warranty, guaranty or promise except as set forth herein; and no agreement, statement, representation or promise made by any such person which is not contained herein shall be valid or binding on either party.

9. Successors and Assigns. This Agreement shall be binding upon and inure to the benefit of the heirs, executors, administrators, successors, and assigns of the parties hereto, and shall survive Close of Escrow.

10. Tax Withholding. To the extent applicable to this transaction, Seller and Buyer shall comply with federal (FIRPTA) and California tax withholding laws.

11. Attorneys' Fees. In the event of a suit relating to, arising out of, or in order to enforce any provision of this Contract, the Parties agree that each Party shall bear their own attorney's fees and costs.

12. Default. In the event of a breach or default under this Agreement by either party, the non-defaulting party shall have, in addition to all rights available at law or equity, the right to terminate this Agreement and the Escrow for the purchase and sale of the Easement, by delivering written notice thereof to the defaulting party and to Escrow Holder, and if Buyer is the non-defaulting party, Seller shall pay Escrow cancellation charges. Such termination of the Escrow by a non-defaulting party shall be without prejudice to the non-defaulting party's rights and remedies at law or equity.

13. Time. Time is of the essence of this Agreement, and of all performances required under this Agreement.

14. Amendments. Any amendments to this Agreement shall be effectively only when duly executed by the parties and deposited with Escrow Holder.

15. Interpretation. The parties agree that each party has reviewed and revised this Agreement and have had the opportunity to have their counsel and real estate advisors review and revise this agreement and that any rule of construction to the effect that ambiguities are to be resolved against the drafting party shall not apply in the interpretation of this Agreement or any amendments or exhibits thereto. In this Agreement the neuter gender includes the feminine and masculine, and singular number includes the plural, and the words "person" and "party" include corporation, partnership, firm, trust, or association wherever the context so requires. The recitals and captions of the sections and subsections of this Agreement are for convenience and reference only, and the words contained therein shall in no way be held to explain, modify, amplify or aid in the interpretation, construction or meaning of the provisions of this Agreement.

16. Counterparts. This Agreement may be executed in any number of counterparts, each of which shall be deemed to be an original, but all of which together shall constitute one and the same instrument. A scanned, electronic, facsimile, or other copy of a party's signature shall be accepted and valid as an original.

17. Warranty of Authority. The signatories to this Agreement warrant and represent that each is authorized to execute this Agreement and that their respective signatures serve to legally obligate their respective representatives, agents, successors, and assigns to comply with the provisions of this Agreement.

[signature page follows]

IN WITNESS WHEREOF, the parties hereto have executed this Agreement as of the day and year first written above.

SELLER:

LAS LOMITAS ELEMENTARY SCHOOL DISTRICT

By: _____
[name]
[title]

Date: _____

Approved as to Form:

John Nibbelin
County Counsel

Date: _____

BUYER:

WEST BAY SANITARY DISTRICT

By: _____
Sergio Ramirez
General Manager

Date: _____

Approved as to Form:

Tony Condotti
General Counsel

Date: _____

Exhibit A
[attach easement deed]