

1902 - Serving Our Community for over 120 Years - 2023
WEST BAY SANITARY DISTRICT
AGENDA OF BUSINESS
REGULAR MEETING OF THE DISTRICT BOARD
WEDNESDAY, MAY 24, 2023 AT 7:00 P.M.
RONALD W. SHEPHERD ADMINISTRATION BUILDING,
500 LAUREL STREET, MENLO PARK, CALIFORNIA 94025

Board Members

Fran Dehn, President
David Walker, Secretary
Roy Thiele-Sardiña, Treasurer
Edward P. Moritz, Member
George Otte, Member

General Manager

Sergio Ramirez

District General Counsel

Anthony Condotti, Esq.

AGENDA OF BUSINESS

To participate by telephone or Zoom meeting, public comments can be made by joining Zoom meeting at:

<https://us06web.zoom.us/j/83519484618?pwd=VFAzUW9Tc3hvSmtlQWV4U3diUjZEdz09>

Meeting ID: 835 1948 4618 Passcode: 213480

NOTE: The Board may take action on any agendized item unless specifically designated a “discussion” item or a “report.”

1. Call to Order and Roll Call
2. Communications from the Public
3. Consent Calendar
Matters listed under this item are considered routine and will be enacted by one motion. The motion, seconds, and vote are applicable to any included resolutions and recorded accordingly. There will be no separate discussion of these items unless specifically requested by a member of the Board.
 - A. Approval of Minutes for Regular Meeting May 10, 2023 Pg. 3A-1
 - B. Consider Accepting Sewer Facilities Constructed Pursuant to Class 3 Sewer Permit No. 1083 for the Construction of Wastewater Facilities at 500 El Camino Real, Menlo Park, California Pg. 3B-1
 - C. Bank of the West Monthly Investment Portfolio Statements Pg. 3C-1
4. General Manager’s Report Pg. 4-1
5. Consider Amending the Long-Term Agreement with Sharon Heights Golf and Country Club to include the Avy-Altschul Pump Station Pg. 5-1
6. Consider Awarding the Avy-Altschul Pump Station Project to Casey Construction, Inc. Pg. 6-1

7. Consider Establishing Date and Time of Public Hearing to Consider Annual Tax Roll Sewer Service Charge Report for Fiscal Year 2023/2024 Pg. 7-1
8. Discussion and Direction on Sharon Heights Recycled Water Plant Pg. 8-1
9. Discussion and Direction on Bayfront Recycled Water Project and Status Update Pg. 9-1
10. Report and Discussion on South Bayside Waste Management Authority (SBWMA) Pg.10-1
11. Report and Discussion on Silicon Valley Clean Water (SVCW) Plant Pg. 11-1
12. Comments or Reports from Members of the District Board and Consider Items to be Placed on Future Agenda
13. Adjournment

The West Bay Sanitary District does not discriminate against persons with disabilities. Upon request, the agenda and agenda packet can be provided in a format to accommodate special needs. If you require a copy of the agenda or related materials in an alternative format to accommodate a disability, or if you wish to attend this public meeting and will require special assistance or other special equipment, please call the District at (650) 321-0384 at least five days in advance and we will make every reasonable attempt to provide such an accommodation.



1902 - Serving Our Community for over 115 Years - 2023

**WEST BAY SANITARY DISTRICT
MINUTES OF THE REGULAR MEETING OF THE DISTRICT BOARD
WEDNESDAY, MAY 10, 2023 AT 7:00 P.M.**

1. Call to Order

President Dehn called the meeting to order at 7:06 PM

Roll Call

BOARD MEMBERS PRESENT: President Dehn, Secretary Walker, Treasurer Thiele-Sardiña, Director Moritz, Director Otte

BOARD MEMBERS ABSENT: None

STAFF MEMBERS PRESENT: Ramirez, Fisher, and Condotti and Bergeron by Zoom

Others Present: None

2. Communications from the Public: None.

3. Consent Calendar

CONSIDERATION OF ITEM(S) REMOVED FROM THE CONSENT CALENDAR

Discussion/Comments: None.

- A. Approval of Minutes for Regular Meeting April 26, 2023
- B. Approval of Minutes for Special Meeting May 3, 2023
- C. Approval of the Financial Activity Report Authorizing Payment of Certain Bills and Salaries and Consideration of Other Financial Matters thru April 30, 2023
- D. WBSD Operations and Maintenance Report – April 2023
- E. Town of Los Altos Hills Operations and Maintenance Report for Work Performed by WBSD – April 2023
- F. Town of Woodside Operations and Maintenance Report for Work Performed by WBSD – April 2023

Motion to Approve by: Moritz 2nd by: Thiele-Sardina Vote: AYE: 5 NAY: 0 Abstain: 0

7. Presentation on ADP Payroll System

Discussion/Comments: Finance Manager Fisher and Personnel and Accounting Specialist Bergeron gave a presentation on the District's implementation of ADP online payroll system.

4. General Manager's Report

Discussion/Comments: General Manager Ramirez reported Ranger Pipelines is in the process of securing materials for the Bayfront Sewer Project. He also reported the new Associate Engineer will start mid-June. He continued to report the second tax roll installment has been received from San Mateo County in the amount of \$7.5M. He also reported the call for bids for the Levee Project will be in late May. In addition, he informed the Board staff is working with Streamline on a website upgrade. General Manager Ramirez reported staff are working on a solution for a newly discovered District sewer mains and cross connections within the Atherton storm drain system. The Board asked General Manager Ramirez to send written correspondence to the Town of Atherton regarding the cross connection and to inform them of their liability for cost and any sanitary sewer overflows (SSOs). The next regular Board meetings will be held on May 24th and June 14th. The complete General Manager's written report is in the May 10th, 2023, agenda packet.

5. Consider Approving District Treasury Report Third Quarter FY 2022-23

Motion to Approve by: Thiele-Sardina 2nd by: Walker Vote: AYE: 5 NAY: 0 Abstain: 0

Discussion/Comments: Finance Manager Fisher reported the District had \$81,786,187 in cash and investments, including \$2,233,431 in restricted accounts, as of March 31, 2023.

The District allocated an additional \$361,837 of LAIF funds for the Operating Reserve, as approved in the FY 2022-23 budget, to meet six months of expenditures. There was \$3.95 million in transfers in the approved FY 2022-23 Budget. The board approved additional transfers on June 22, 2022, December 14, 2022, and February 8, 2023, for a total of \$15.2 million in transfers in FY 2022-23. \$10 million in transfers were made to achieve the target balance in all reserves on December 20, 2022. An additional \$3 million in transfers was made February 10, 2023 to achieve higher targets for Capital Projects and Emergency Capital Reserves.

The District had total funds of approximately \$22.4 million above the total \$57 million target reserve balances, combining all District unrestricted accounts, as of March 31, 2023. All reserve accounts have achieved the individual targets approved by the board.

The investment portfolios have been set up with the rate of return goal of 2%. Current District yields in the Investment Reserves average 2.12%. LAIF's yield was 2.74% for the third quarter.

6. Consider Approving the Financial Statements FY 2022-23, Third Quarter Ending 3/31/2023

Motion to Approve by: Dehn 2nd by: Thiele-Sardina Vote: AYE: 5 NAY: 0 Abstain: 0

Discussion/Comments: Finance Manager Fisher reported The District had \$186,805,628 in total assets as of March 31, 2023, with total liabilities of \$18,727,157, for a Net Position of \$165,618,427, with Deferred Outflows and Inflows of Resources of \$262,201 and \$2,722,245, respectively. The District had a gross Revenue of \$24,981,881 and gross Expenditures of \$20,754,429, for a total \$5,678,652 increase in Net Position, including non-operating income and expense, through the quarter ending March 31, 2023 for all Funds. The District also expended \$1,902,216 on capital construction.

8. Consideration to Approve Purchase of Two 2023 F150 Lightnings (EV)

Motion to Approve by: Thiele-Sardina 2nd by: Walker Vote: AYE: 5 NAY: 0 Abstain: 0

Discussion/Comments: None.

9. Discussion and Direction on the Capital Improvement Program

Discussion/Comments: General Manager Ramirez reported on the District's Capital Improvement Program (CIP.) Following the discussion period, the Board asked to see the carryover dollar amounts as part of the budget and the difference of cost between the CIP projected costs and revised estimates. The Board would like the District to coordinate projects with the City of Menlo Park to help reduce costs.

10. Report and Discussion on Sharon Heights Recycled Water Plant

Discussion/Comments: General Manager Ramirez reported the school board will consider approval of the easement for the Avy Altschul Pump Station later in May. He also reported General Counsel is reviewing the update to the long-term agreement with SHGCC. He reported bids are due for the project on May 16 and staff have begun to procure equipment.

11. Discussion and Direction on Bayfront Recycled Water Project and Status Update

Discussion/Comments: General Manager Ramirez reported habitat monitoring is underway by SCWA. Freyer and Laureta are preparing the bid packet for the Levee Project. In addition, he reported Woodard & Curran are coordinating a kickoff meeting that will include the Recycled Water Committee for the Bayfront Recycled Water Project.

12. Report & Discussion on South Bayside Waste Management Authority (SBWMA)

Discussion/Comments: President Dehn reported Board meetings are now in-person and held at the San Mateo County Transit District Office in San Carlos. The next meeting will be a retreat held at Canada College on May 25th in which she cannot attend. She asked if another Board member wished to attend. Mr. Otte asked to have information on the retreat emailed to him. President Dehn also reported the SBWMA updated their employee policy and was approved at the last meeting. In addition, she reported the administrative building restoration is nearly complete after suffering water damage during the winter storms.

13. Report, Discussion & Direction on Silicon Valley Clean Water (SVCW) and Discussion on SVCW CIP Program and Financing

Discussion/Comments: Director Otte reported the pipeline repair is estimated at \$550,000. He also reported that SVCW General Manager's review is underway, and negotiations are complete for the union.

14. Comments or Reports from Members of the District Board and Consider Items to be Placed on Future Agenda

Discussion/Comments: Treasurer Thiele-Sardina requested an agenda item be placed in a future meeting to discuss LAFCo assisting with the divestiture of Solid Waste franchise.

15. Adjournment Time: The meeting was adjourned at 9:12 PM

THIS PAGE LEFT INTENTIONALLY BLANK



WEST BAY SANITARY DISTRICT AGENDA ITEM 3B

To: *Board of Directors*

From: *Fariborz Heydari, P.E., Project Manager*

Subject: **Consider Accepting Sewer Facilities Constructed Pursuant to Class 3 Sewer Permit No. 1083 for the Construction of Wastewater Facilities at 500 El Camino Real, Menlo Park, California**

Background

This permit was for rerouting the existing 8" public sewer main out of the sidewalk area and into El Camino Real as part of Middle Plaza Project at 500 El Camino Real. The new main installed in El Camino Real consists of two pipe sections of approximately 655 LF of 8" main and 850 LF of 12" main.

Analysis

The Board issued this permit 1083 at the Regular Meeting of January 9, 2018.



The work has been completed and has been inspected, tested, and approved by staff as being in conformance with District standards. The property owner has submitted a one-year guarantee for the work in the form of a maintenance bond.

Recommendation

The Project Manager recommends that the Board accepts these facilities and directs the General Manager to approve the Class 3 Permit No. 1083.

Attachments: Class 3 Permit No. 1083
Exhibit A: Site map



	PROPOSED MAIN REALIGNMENT
	REALIGNMENT THROUGH SEPARATE PERMIT

MIDDLE PLAZA AT 500 EL CAMINO REAL

El Camino Real



Esri, HERE, Garmin, © OpenStreetMap contributors, and the GIS user community, Source: Esri, DigitalGlobe, GeoEye, Earthstar Geographics, CNES/Airbus DS, USDA, USGS, AeroGRID, IGN, and the GIS User Community

WEST BAY SANITARY DISTRICT

500 Laurel Street
Menlo Park, California 94025
(650) 321-0384

Permit Number
No 1083

Type _____

APPLICATION FOR CLASS 3 SEWER PERMIT

To the WEST BAY SANITARY DISTRICT:

The undersigned, being the Owner Owner's Agent of the property located at

500 El Camino Real, Menlo Park

does hereby request permission to construct sanitary sewers and related facilities to serve a

Residential Non-residential Development at said location.

ENGINEER'S

Sandis
Civil Engineers Surveyors Planners

Name

1700 S. Winchester Blvd, Campbell, CA
95008

Address

CONTRACTOR'S

Palisade Builders Inc.

Name

1875 S. Bascom Ave. Ste 2400, Campbell, CA
95008

Address

OWNER'S

Stanford University

Name

3160 Porter Drive Suite 200, Palo Alto, CA
94304

Address

Jan Murray

Applicant's Signature

Jan Murray

Signed by - Please Print Name

1700 S. Winchester Blvd, Campbell, CA
95008

Address

T. Reese 3/26/15

Receipt of \$ 2,545 Application Fee is hereby acknowledged.

Date

Receipt of \$ 2,545 Cash deposit or Performance Bond

Comments: 1741 LF of water main which consist of 8" and 12" PVC C900
pipes with 8 manhole structures 208 LF of sewer lateral connections
which consist of 6" and 8" PVC C900 pipes with 4 drop ss clean
out structures

Approved by the District Board on _____

Application approved and permit issued:

WEST BAY SANITARY DISTRICT

Sergio Ramirez, General Manager

Date _____

By _____

Final Acceptance by the District Board on _____

(SEE PERMIT CONDITIONS ON REVERSE)

THIS PAGE LEFT INTENTIONALLY BLANK



WEST BAY SANITARY DISTRICT AGENDA ITEM 3C

To: *Board of Directors*

From: *Debra Fisher, Finance Manager*

Subject: *Bank of the West Monthly Investment Portfolio Statements*

Background

In October 2010 the District named Bank of the West as the District's Investment advisor and approved an investment of \$5 million in available funds to establish the Emergency Capital Reserve. Subsequently, the Board has established several additional reserves to provide financial stability for the District. On June 9, 2021, the Board approved an increase in the Operating Reserve to six months of operations, based on the current budget, held in the Local Agency Investment Fund (LAIF), in order to have the funds more accessible. This is necessary, as Operating Reserves are intended to fund the District between July 1st and December each year, when the County of San Mateo delivers the first installment of sewer service charges collected through tax rolls, which accounts for the majority of funding. On February 8, 2023, the Board approved the current Reserve Policy, which increased the Capital Projects and Emergency Capital Reserves by \$2 and \$1 million, respectively.

Excess funds over the current monthly expenditures are held in Local Agency Investment Fund (LAIF), which are equivalent to cash and may earn higher yields without a long term commitment. Operating Reserves, customer deposits, current capital projects, and Solid Waste Funds are held in LAIF.

Restricted funds for Sharon Heights Golf & Country Club (SHGCC), as required for the Clean Water State Revolving Fund (SRF) loan are held in a separate restricted account.

There are currently five separate investment reserves maintained to support the goals of the District, along with reserves held in LAIF, the Vehicle & Equipment Reserve held in a money market account, and the restricted Pension Trust and Recycled Water State Revolving Fund (SRF) Reserves. Annual contributions are made in accordance with the Board approved budget and periodically evaluated.

<u>Reserve Account</u>	<u>Originated</u>	<u>Target Balance</u>	<u>Target</u>
Operating Reserve	11/26/2014	\$11.1 million	Achieved
Rate Stabilization Reserve	10/30/2015	\$10 million	Achieved
Treatment Plant Reserve	8/01/2021	\$12 million	Achieved
Capital Project Reserve	11/26/2014	\$8 million	Achieved
Emergency Capital Reserve	10/19/2010	\$6 million	Achieved
Recycled Water Cash Flow	11/18/2016	\$8 million	Achieved
Recycled Water SRF Reserve	3/01/2018	\$1.46 million	Achieved
Vehicle & Equipment Reserve	8/18/2011	\$1 million	Achieved

Fiscal Impact

The District has approximately \$88.7 million in all reserve and bank accounts as of April 30, 2023, including restricted funds. There were \$3.95 million in transfers in the approved FY 2022-23 Budget. The board approved additional transfers on June 22, 2022, December 14, 2022, and February 8, 2023, for a total of \$15.5 million in transfers in FY 2022-23.

<u>District Funds</u>	<u>4/30/2023</u>
Cash Equivalent Accounts	41,817,260
Investment Accounts - Unrestricted	44,633,349
Public Agency Retirement Services (PARS Trust)	721,099
SHGCC SRF Loan Deposit	1,517,364
Total District Funds	88,689,071

Effective July 1, 2022, the Operating Reserve target increased to \$11.1 million for six months of operations, based on the approved budget for Fiscal Year 2022-23. As of April 30, 2023 all reserves have reached their target balance.

**Cash & Investments
April 30, 2023**

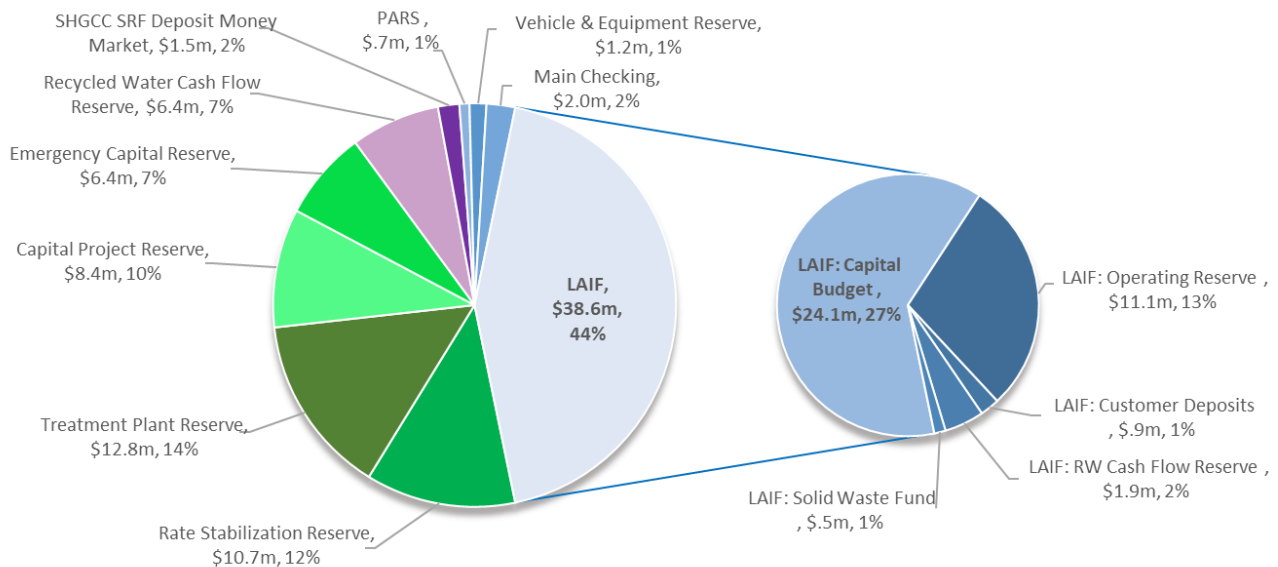

The monthly statement synopsis indicating the amount of each reserve fund the District holds in the Bank of the West Investment Portfolios are attached. Quarterly reports on the Investment Portfolios will include details of investments of each reserve account.

Recommendation

The Finance Manager recommends the District Board accept the Investment Portfolio Statements by affirming and approving the items listed in the Consent Calendar.

Attached: 2023-04 Investment Reserve Accounts

WBSD RATE STABILIZATION RESERVE AGY

Statement Period: **04/01/23 - 04/30/23**

WEST BAY SANITARY DISTRICT
500 LAUREL STREET
MENLO PARK CA 94025

Fiduciary
Chuen Ying Lee
(408) 645-3234
Portfolio
Michael D. Smith
(408) 490-2079

Asset Allocation

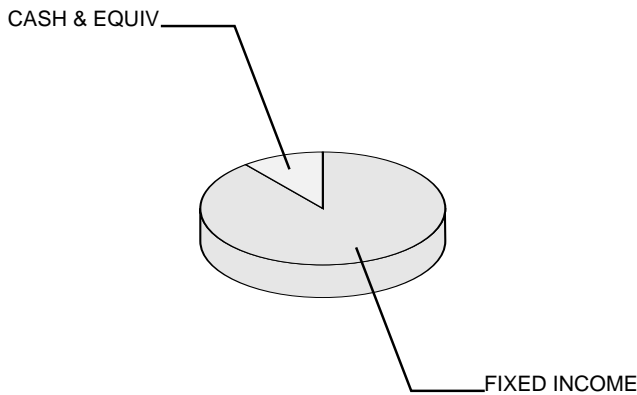

Asset Valuation

Description	Market Value	% of Account
Cash & Equiv	1,180,775.49	11.1%
Fixed Income	9,425,206.24	88.9%
Total Portfolio	\$ 10,605,981.73	100.0%
Accrued Income	64,010.92	
Total Valuation	\$ 10,669,992.65	

Market Reconciliation

	Current Period	Year To Date
Beginning Market Value	\$ 10,635,712.44	\$ 9,737,901.10
Income		
Interest.....	11,117.11	178,828.44
Purchased Income.....	0.00	-8,404.39
Additions.....	0.00	767,700.00
Disbursements.....	-1,378.22	-13,889.09
Realized Gains/(Losses).....	0.00	-60.87
Change In Accrued Income.....	8,587.70	12,136.41
Change In Market Appreciation/(Depreciation).....	16,858.25	67,121.01
Non-Cash Asset Changes.....	-904.63	-71,339.96
Ending Market Value	\$ 10,669,992.65	\$ 10,669,992.65

WBSD - TREATMENT PLANT RESERVE AGY

Statement Period: 04/01/23 - 04/30/23

WEST BAY SANITARY DISTRICT
500 LAUREL STREET
MENLO PARK CA 94025

Fiduciary
Chuen Ying Lee
(408) 645-3234
Portfolio
Michael D. Smith
(408) 490-2079

Asset Allocation

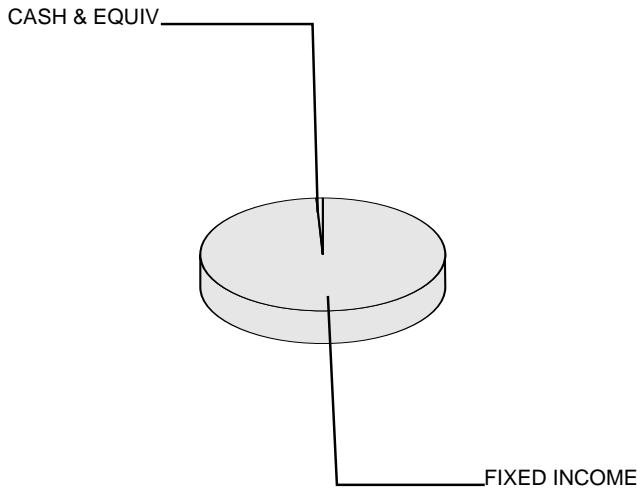

Asset Valuation

Description	Market Value	% of Account
Cash & Equiv	78,999.85	0.6%
Fixed Income	12,640,049.00	99.4%
Total Portfolio	\$ 12,719,048.85	100.0%
Accrued Income	89,103.79	
Total Valuation	\$ 12,808,152.64	

Market Reconciliation

	Current Period	Year To Date
Beginning Market Value	\$ 12,762,722.08	\$ 2,493,136.18
Income		
Interest.....	1,211.00	109,413.35
Purchased Income.....	0.00	-61,578.86
Additions.....	0.00	10,118,211.08
Disbursements.....	-1,653.50	-10,330.87
Realized Gains/(Losses).....	0.00	0.00
Change In Accrued Income.....	19,865.26	78,914.07
Change In Market Appreciation/(Depreciation).....	3,438.95	19,355.83
Non-Cash Asset Changes.....	22,568.85	61,031.86
Ending Market Value	\$ 12,808,152.64	\$ 12,808,152.64

WBSD - CAPITAL PROJECT RESERVE AGY

Statement Period: **04/01/23 - 04/30/23**

WEST BAY SANITARY DISTRICT
500 LAUREL STREET
MENLO PARK CA 94025

Fiduciary Chuen Ying Lee (408) 645-3234
Portfolio Michael D. Smith (408) 490-2079

Asset Allocation

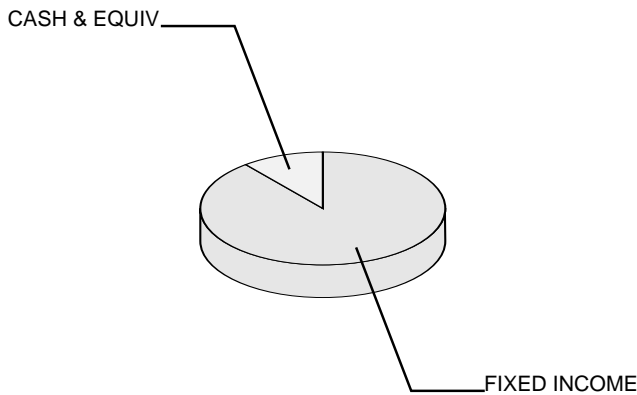

Asset Valuation

Description	Market Value	% of Account
Cash & Equiv	902,857.63	10.7%
Fixed Income	7,503,111.10	89.3%
Total Portfolio	\$ 8,405,968.73	100.0%
Accrued Income	37,448.72	
Total Valuation	\$ 8,443,417.45	

Market Reconciliation

	Current Period	Year To Date
Beginning Market Value	\$ 8,413,196.17	\$ 5,830,876.97
Income		
Interest.....	8,639.97	106,536.87
Purchased Income.....	0.00	-7,760.40
Additions.....	0.00	2,479,000.00
Disbursements.....	-1,091.60	-8,849.98
Realized Gains/(Losses).....	0.00	0.00
Change In Accrued Income.....	4,201.31	2,865.64
Change In Market Appreciation/(Depreciation).....	21,278.40	67,106.62
Non-Cash Asset Changes.....	-2,806.80	-26,358.27
Ending Market Value	\$ 8,443,417.45	\$ 8,443,417.45

WBSD - EMERGENCY CAPITAL RESERVE

Statement Period: **04/01/23 - 04/30/23**

WEST BAY SANITARY DISTRICT
500 LAUREL STREET
MENLO PARK CA 94025

Fiduciary
Chuen Ying Lee
(408) 645-3234
Portfolio
Michael D. Smith
(408) 490-2079

Asset Allocation

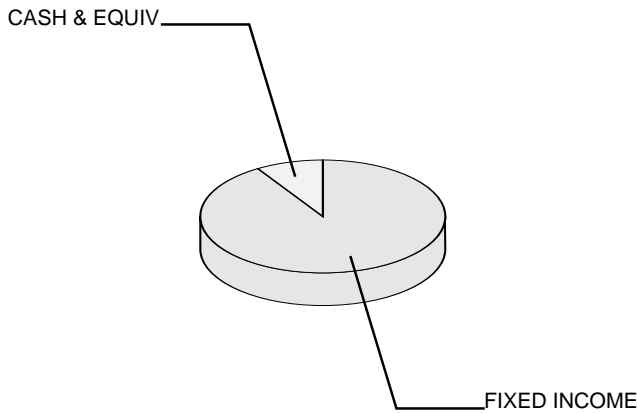

Asset Valuation

Description	Market Value	% of Account
Cash & Equiv	547,938.49	8.7%
Fixed Income	5,775,147.96	91.3%
Total Portfolio	\$ 6,323,086.45	100.0%
Accrued Income	32,806.73	
Total Valuation	\$ 6,355,893.18	

Market Reconciliation

	Current Period	Year To Date
Beginning Market Value	\$ 6,335,703.82	\$ 4,877,961.83
Income		
Interest.....	7,382.71	89,859.69
Purchased Income.....	0.00	-6,128.87
Additions.....	0.00	1,381,100.00
Disbursements.....	-821.41	-7,211.70
Realized Gains/(Losses).....	0.00	-848.38
Change In Accrued Income.....	2,839.55	4,700.42
Change In Market Appreciation/(Depreciation).....	13,460.18	42,859.48
Non-Cash Asset Changes.....	-2,671.67	-26,399.29
Ending Market Value	\$ 6,355,893.18	\$ 6,355,893.18

WBSD - RECYCLED WATER CASH FLOW AGY

Statement Period: **04/01/23 - 04/30/23**

WEST BAY SANITARY DISTRICT
500 LAUREL STREET
MENLO PARK CA 94025

Fiduciary
Chuen Ying Lee
(408) 645-3234
Portfolio
Michael D. Smith
(408) 490-2079

Asset Allocation

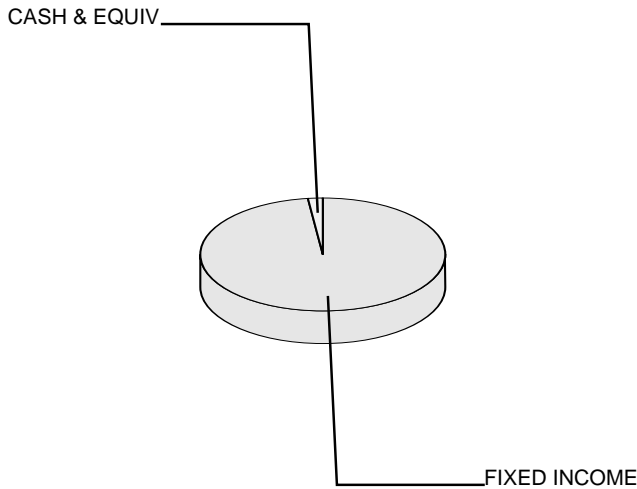

Asset Valuation

Description	Market Value	% of Account
Cash & Equiv	110,794.78	1.8%
Fixed Income	5,991,005.55	98.2%
Total Portfolio	\$ 6,101,800.33	100.0%
Accrued Income	33,196.09	
Total Valuation	\$ 6,134,996.42	

Market Reconciliation

	Current Period	Year To Date
Beginning Market Value	\$ 6,121,463.04	\$ 5,623,527.18
Income		
Interest.....	414.16	93,891.85
Purchased Income.....	0.00	-3,939.82
Additions.....	0.00	456,100.00
Disbursements.....	-794.36	-8,002.55
Realized Gains/(Losses).....	0.00	0.00
Change In Accrued Income.....	9,850.63	7,926.76
Change In Market Appreciation/(Depreciation).....	3,149.98	-54,035.58
Non-Cash Asset Changes.....	912.97	19,528.58
Ending Market Value	\$ 6,134,996.42	\$ 6,134,996.42

THIS PAGE LEFT INTENTIONALLY BLANK



WEST BAY SANITARY DISTRICT AGENDA ITEM 4

To: *Board of Directors*

From: *Sergio Ramirez, General Manager*

Subject: *General Manager's Report*

1) **Administrative:**

- a. Staff are finalizing the FY2023/24 budget and will bring a final budget to the Board on June 14, 2023. The budget should contribute over \$6 million to the Capital Fund after all operational expenses.
- b. Staff met with representatives for the Willow Village Project to discuss the sanitary sewer plans. Their plans include a new "Willow Village" pump station. The pump station will take flows off of the Kavanaugh and O'Brien sewer system which contributes to the Willow Pump Station. The District will be asked to share in the cost for the additional work.

2) **Finance:**

- a. The monthly O&M and Capital Fund payment for Silicon Valley Clean Water is expected to increase by .4%.
- b. The Finance Manager and Personnel & Accounting Specialist presented a report on the ADP payroll system to the Board at the May 10th Regular Board Meeting.

3) **CIP Projects:**

a. **Construction Capital Improvement Program (CIP):**

- i. The High Frequency Point Repair Project was awarded to Casey Construction. Construction is expected to begin in late May.
- ii. A preconstruction meeting for the Bayfront Park Sewer Improvements Project was held on May 16, 2023 to discuss coordination efforts. Ranger Pipelines Inc. has secured the 42 inch and 36 inch PVC pipe for the project and will begin once the final permits are in place.

b. **Levee Improvement Project:**

- i. All necessary permit conditions have been issued for the Levee Improvement Project.
- ii. The Levee Improvement Project will be going out for bid at the end of May.
- iii. Levee preconstruction monitoring is going well. The General Manager will give an update at the Regular Board Meeting.

4) **Information Technology (IT):**

- a. Staff are working with Streamline on the new website. A website Board update presentation is scheduled for June 14, 2023.

5) **Operations and Maintenance:**

a. **Collection System:**

- i. The crew hosted a Hands-On By-Pass training event at the District offices. Approximately, 12 outside agencies attended the training from throughout the Bay Area.
 - b. **Pump Facilities:**
 - i. The Willow Pump Station stationary generator is back online. The portable generator was deployed to the Vintage Oaks pump station because of a failure at that station's generator.
 - c. **Training:**
 - i. Field personnel received Traffic Control and Flagger Training on May 15, 2023.
- 6) **Water Quality:**
- a. **Sharon Heights Golf and Country Club (SHGCC):**
 - i. The District received three bids for the Avy Altschul Pump Station Project. The apparent low bidder was Casey Construction at approximately \$895,000.
 - ii. Staff and SHGCC are working out the solar panel placement details for the Solar Project.
 - b. **Bayfront Recycled Water Facility (BRWF):**
 - i. Project Management and Design has begun and should take approximately six months to be at the 30% design stage. The Recycled Water Committee will be asked to help select the Design Build Team who will construct the facility. A kickoff meeting is tentatively scheduled for May 31, 2023.
 - c. **Woodside Recycled Water Facility (BRWF):**
 - i. The Woodside Recycled Water Facility feasibility will conclude soon. A full report will be brought to the District Board by Woodard & Curran.
- 7) **Fleet and Facilities:**
- a. **Vehicle Maintenance:**
 - i. The Board approved the purchase of two Ford EV F-150 Lightnings which should be in by the end of May.
- 8) **Personnel:**
- i. A COVID-19 policy is under review.
- 9) **Upcoming Events:**
- a. **Next Regular Board Meetings:** Wednesdays, May 24th and June 14th.
- 10) **Misc. Items:**
- a. **West Bay:** The District has experienced two sanitary sewer overflows (SSOs.) Both were due to pipeline structural defects.
 - b. **Town of Los Altos Hills:** The Town has experienced one sanitary sewer overflow this year.
 - c. **Town of Woodside:** The District requested the Town conduct Smoke Testing to help identify Inflow and Infiltration issues.



WEST BAY SANITARY DISTRICT AGENDA ITEM 5

To: *Board of Directors*

From: *Sergio Ramirez, General Manager*

Subject: *Consider Amending the Long-Term Agreement with Sharon Heights Golf and Country Club to include the Avy-Altschul Pump Station*

Background

In agreement with Sharon Heights Golf and Country Club (SHGCC), the District Board approved the design of a small pump station near the intersection of Avy Avenue and Altschul Avenue in Menlo Park that would divert wastewater to the SHGCC Recycled Water Facility to create additional recycled water. This pump station was envisioned as a simplex pump station (one pump).

The pump station was designed and sited on Los Lomas Elementary School District property in a new easement that abuts against an existing sanitary sewer easement through the same property. Gravity sewer mains diverting wastewater to this pump station were designed from the intersection of Avy and Altschul to the new pump station. The pump station discharges into a previously constructed forcemain pipe in Altschul Avenue and Sharon Road. This forcemain discharges into a gravity pipeline at the intersection of Sharon Road and Eastridge Avenue and ultimately drains to the main diversion pump station near the intersection of Vine Street and Sand Hill Road, where it is then pumped to the SHGCC Recycled Water Facility for treatment.

The District Board authorized the General Manager to call for bids on the project on March 22, 2022. Three construction companies submitted bids for the project. The anticipated construction cost for this project was \$950,000.

Analysis

The Long-Term Agreement (LTA) between the District and the SHGCC requires an amendment to include the Avy Altschul Pump Station project and the SHGCC's obligations and responsibilities for repayment.

The District's General Counsel has collaborated with the SHGCC's attorney on the amendment. See the attached LTA Draft Amendment.

Fiscal Impact

SHGCC has committed to funding the Avy-Altschul Pump Station Project through a Sharon Heights Golf and Country Club Recycled Water Facility - Long Term Agreement Amendment. The District applied for a loan from the State Water Resources Control Board (SWRCB) State Revolving Fund (SRF) to design and construct the pump station. The SWRCB awarded the project \$950,000.00 including an approximate \$300,000.00 in State grants. There is no fiscal impact to the District's General Fund as the SRF loan will be repaid by SHGCC.

Recommendation

The General Manager recommends the District Board of Directors authorize the General Manager and District's General Counsel to execute the LTA Amendment.

Attachment: LTA Draft Amendment

**DRAFT-AMENDMENT ONE TO AGREEMENT FOR CONSTRUCTION,
OPERATION AND MAINTENANCE OF RECYCLED WATER TREATMENT FACILITY
AND DELIVERY OF RECYCLED WATER**

THIS AMENDMENT ONE TO AGREEMENT FOR CONSTRUCTION, OPERATION AND MAINTENANCE OF RECYCLED WATER TREATMENT FACILITY AND DELIVERY OF RECYCLED WATER (“Amendment One”) is made and entered into on the date by which it has been duly executed by all Parties (the “Effective Date”) between the West Bay Sanitary District (“West Bay”), a sanitary district organized and existing under the Sanitary District Act of 1923 (Cal. Health & Safety Code §6400, et seq.) and Sharon Heights Golf & Country Club (“Sharon Heights”), a corporation organized and existing under the laws of the State of California. (West Bay and Sharon Heights are collectively the “Parties”).

RECITALS

- A. On or about April 20, 2015, the Parties entered into a Memorandum of Understanding Establishing Principles of Agreement for the Design, Construction and Operation of Recycled Water Treatment Facility (the “MOU”) setting forth the principles governing the negotiations of the Parties regarding Sharon Heights’ utilization of tertiary-treated recycled water (“Recycled Water”) from treatment facilities to be located on property owned by Sharon Heights at the Sharon Heights Golf & Country Club, located at 2900 Sand Hill Road, Menlo Park, California (the “Project”).
- B. The Parties entered into two Addenda to amend the MOU, Addendum One effective November 24, 2015 and Addendum Two effective April, 2016 (collectively, the “Amended MOU.”)
- C. On June 22, 2016, the Parties entered into a User Agreement for the use of Recycled Water from the recycled water treatment facility for the Project on Sharon Heights’ property in order to complete the State Revolving Fund Loan Application.
- D. On or about June 28, 2017, the Parties entered into a Long Term Agreement (the “LTA”) governing the design, construction and operation of the Project; and
- E. On June 29, 2017, the Parties also entered into a Memorandum of Understanding Between Sharon Heights Golf and Country Club and West Bay Sanitary District Regarding the Development of Additional Pump Stations to Service the Recycled Water Treatment Facility on Sharon Heights’ Property (the “Option 5 MOU”), specifying the terms and conditions under which West Bay would design and construct a pump station to pump additional flow from Avy and Altschul Avenues, into the Sewer Forcemain, to Manhole H13-143 as a supplemental source of untreated wastewater to the Project (the “Avy-Altschul Project”); and
- F. On or about December 8, 2021, the Parties entered into the Agreement Between West Bay Sanitary District and Sharon Heights Golf and Country Club for a State Revolving Fund Loan Application to Facilitate the Design and Construction of the Avy Altschul Pump Station (the “Avy-Altschul Project Financing Agreement”); and
- G. On or about October 13, 2021, the Parties entered into the Memorandum of Agreement for Reimbursement Costs Associated with Design of Pump Station Project at Avy Avenue and Altschul Avenue, Menlo Park, by and between West Bay Sanitary District and Sharon Heights Golf and Country Club.

- H. On or about March 22, 2023, the Board of Directors authorized and directed the General Manager to issue the call for bids for the Avy-Altschul Project, at an anticipated construction cost of \$950,000.
- I. The Parties seek to Amend the LTA to incorporate the terms and conditions under which West Bay will construct and operate the Avy-Altschul Project, and Sharon Heights will reimburse West Bay for all costs associated with that Project, including land acquisition, planning, permitting, construction, operation, maintenance/replacement and debt service.

The Parties hereby agree that the LTA shall be, and is, amended as follows:

- 1. Article 1. Definitions is amended as follows:
 - A. "Facility" or "Facilities" is added to read as follows:
"Facility" or "Facilities" mean the On-Site Facilities and the Off-Site Facilities, as further defined herein.
 - B. "Off-Site Facilities" is amended to read as follows:
"Off-Site Facilities" means a wastewater pump station, transmission pipeline to divert untreated flow to On-Site Facilities, and the necessary pipeline to discharge solids to the existing sewer transmission pipeline, and include a pump station and pipeline to pump additional flow from Avy and Altschul Avenues, into the Sewer Forcemain, to Manhole H13-143.'
 - C. "Operations and Maintenance Costs" is amended to read as follows:

"Operations and Maintenance Costs," or "O&M Costs," includes all of the following annual expenses as further detailed in Exhibit F (Sharing of Information), attached hereto and incorporated herein by reference, as determined by West Bay, to be paid by Sharon Heights for the duration of the Term of this Agreement:
 - A. All direct and indirect labor costs (indirect labor costs are defined as 3rd party vendors/contractors) required for operation, maintenance, repair or, to the extent necessary to comply the SRF Loan Agreement's requirements, replacement of the Project Facilities.
 - B. Cost of utilities, including, but not limited to, electricity, telecommunications, water and/or sewer (to the extent that such utilities are not furnished by Sharon Heights as part of its normal operations).
 - C. Cost of maintenance, repair or replacement of any Project Facilities-related equipment and establishment of adequate capital reserves (District will return net interest on the account to the Club annually).
 - D. Costs of insurance, regulatory compliance or reporting requirements, laboratory testing, consultants or services deemed necessary by West Bay in connection with O&M.

E. Cost of supplies, including but not limited to, chemicals, filter membranes, UV lamps etc.; and

F. Administrative and overhead expenses in the amount of fifteen percent (15%) of the sum of items A, C, D and E, above, except direct costs and the amount contributed to the Capital Reserve/Sinking fund.

- D. "SRF Loan Agreement" is hereby renamed "SRF Loan Agreements" to read as follows:
"SRF Loan Agreements" mean the Installment Sale Agreement and Grant—West Bay Sanitary District Recycled Water Project—Sharon Heights, Water Recycling Project No. 8163-110, Agreement No. D16001018 entered into by and between West Bay Sanitary District and the California State Water Resources Control Board; and the Installment Sale Agreement and Grant—West Bay Sanitary District Avy/ Altschul Pump Station Project No. _____, Agreement No. _____ entered into by and between West Bay Sanitary District and the California State Water Resources Control Board.

2. Article 4 – SRF Loan and Project Payments/Security – is hereby amended at Paragraph 4.02 – SRF Loan and Project Costs – to read as follows:

"4.02 SRF Loans and Project Costs.

As set forth in greater detail herein, West Bay has applied for a loan to finance the cost of advance planning, design and construction of the initially-approved Project by the State of California's State Revolving Fund ("SRF") loan program. Under the terms of the SRF Loan, West Bay will initially pay all invoices for planning, design and construction services, and then seek reimbursement for such payments through the SRF loan program. Upon completion of the Project, Sharon Heights shall be responsible to West Bay and timely pay to West Bay all amounts required and/or payable under the SRF Loan (including, but not limited to, payment of principal, interest, fees, State Water Board costs and expenses, and any other costs and/or expenses associated with the SRF Loan and associated service payments, collectively referred to herein as "Service Fee Payments") and to complete the Project (even if the SRF Loan funds are insufficient to pay the Project costs and expenses in full) and shall reimburse West Bay for the cost of operations and maintenance of the Project in accordance with the terms set forth herein. West Bay will use good faith efforts to provide Sharon Heights with a reasonable opportunity to review the terms of the SRF Loan, provided, such review does not in any way hinder, impede or delay the SRF Loan process, the Project or the associated procurement process. In addition, West Bay has applied for an SRF loan to finance the cost of advance planning, design and construction of the Avy-Altschul Project including, but not limited to, the cost of acquisition of an exclusive easement for the pump station on property owned by the Las Lomas Elementary School District. Under the terms of the Avy-Altschul SRF Loan, West Bay will initially pay all invoices for land acquisition, planning, design and construction services for the Avy-Altschul Project, and then seek reimbursement for such payments through the SRF loan program. Upon completion of the Avy/Altschul Project, Sharon Heights shall be responsible to West Bay and timely pay to West Bay all amounts required and/or payable under the SRF Loan (including, but

not limited to, payment of principal, interest, fees, State Water Board costs and expenses, and any other costs and/or expenses associated with the SRF Loan and associated service payments, collectively referred to herein as "Avy-Altschul Service Fee Payments") and to complete the Avy-Altschul Project (even if the SRF Loan funds are insufficient to pay the project costs and expenses in full) and shall reimburse West Bay for the cost of operations and maintenance of the Avy-Altschul Project in accordance with the terms set forth herein. West Bay will use good faith efforts to provide Sharon Heights with a reasonable opportunity to review the terms of the SRF Loan, provided, such review does not in any way hinder, impede or delay the SRF Loan process, the Avy-Altschul Project or the associated procurement process"

3. Article 4 – SRF Loan and Project Payments/Security – is hereby amended at Paragraph 4.03 - Sharon Heights' Financial Assurances and West Bay's Due Diligence – Subparagraph B(1) – Reserve Fund – to read as follows:

“(1) Reserve Fund

(a) Sharon Heights will pay West Bay 1.2 times the estimated annual SRF Service Fee Payment as of [date specified in the SRF loan docs] but, no later than the date West Bay issues a notice to proceed to the Design Build Entity.

(b) Sharon Heights will pay West Bay an additional 1 times the estimated annual Service Fee Payment within 30 days after West Bay has provided written notice that the Project has been determined by the State to be substantially complete (the "Substantial Completion Date") for purposes of establishing the due date for the first annual Service Fee Payment. The amounts paid to West Bay by Sharon Heights pursuant to sub-paragraphs (a) and (b) are collectively referred to as the "Reserve Fund".

~~(c)~~ In addition to the Reserve Fund payments specified in Sub-paragraphs (a) and (b), ~~and (b)~~ above, Sharon Heights will pre-pay to West Bay the annual Service Fee Payments in ten equal monthly installments in accordance with Paragraph 6.03-Service Fee Payments, below.

~~(c)~~ The Reserve Fund constitutes a pre-paid deposit toward and security of the SRF Loans, Service Fee Payments thereunder, and the costs and expenses of designing, constructing and completing the Project. At the end of the term of the each SRF Loan, West Bay will utilize Reserve Fund deposits for the remaining Service Fee Payments and any outstanding Project costs in excess of the funds received under the SRF loan (if any). When the Reserve Fund is invested in an interest-bearing account, the interest, net of account administration costs including administration costs related to calculating the accrued interest, will be credited and remain in the account for the term of the SRF Loans.

4. Article 5 – Project Budget – is hereby amended by adding Paragraphs 5.05 – 5.07 to read as follows:

“5.05 Initial/Final Project Budgets – Avy-Altschul Project

The Parties have reviewed and agreed upon the estimated budget for the Avy-Altschul Project in the amount of [] (the "Initial Avy-Altschul Project Cost Budget Estimate"). Once a

contract has been awarded for the Avy-Altschul Project, and the SWRCB has approved the final Avy-Altschul Project budget for incorporation into the Avy-Altschul SRF Loan Agreement, a "Final Avy-Altschul Project Cost Estimate" will be determined. During the course of construction, as project cost estimates are modified or refined, and at least once every six months during the construction phase, West Bay shall update the Final Avy-Altschul Project Cost Estimate and transmit it to Sharon Heights for review and comment. However, in coordination with monthly Project meetings, certain cost information may be shared more frequently.

5.06 Change orders

During construction of the Avy-Altschul Project, should West Bay encounter unforeseen circumstances that require change orders in order to proceed with construction of the Avy-Altschul Project, West Bay may proceed with such change orders, but it will provide Sharon Heights with timely written notice of the same.

During construction of the Project Facilities, West Bay will notify Sharon Heights of change orders for less than \$25,000 at its regular monthly Project team meetings. Notice of any request for a change order for where the cost estimate will exceed the Final Project Cost Estimate by five-percent or more shall be given, in writing, prior to West Bay's agreement to the requested change order. The Parties shall meet and confer in good faith regarding the request prior to any agreement by West Bay to the change order provided, however, that the final determination of whether to accept such a change order shall be made by West Bay in its sole discretion. Nothing contained herein shall relieve Sharon Heights of its obligations to reimburse West Bay in full for the final cost of Project Construction.

5.07 Initial Avy-Altschul Project Cost Outlay, Initial Avy-Altschul Project Cost Budget Estimate and SRF Loan to Finance.

In accordance with the Parties' mutual understanding, the Initial Avy-Altschul Project Cost Budget Estimate contemplates that the Initial Project Cost Outlay will be financed by West Bay's application for and obtaining a State Revolving Fund loan (the "SRF Loan") in the amount of the Initial Avy-Altschul Project Cost Budget Estimate. Under the terms of the contemplated SRF Loan agreement, West Bay will be required to advance Avy-Altschul Project costs and seek reimbursement from the SRF Loan program over the course of the design and construction phase of the Avy-Altschul Project, and that the repayment of said loan agreement shall commence one (1) year after the Avy-Altschul Project is completed and operational. West Bay will provide up to \$950,000 of Working Capital and, if that is exhausted prior to SRF reimbursement, Sharon Heights will commit an any necessary additional Working Capital toward the Avy-Altschul Project. Once SRF Loan Program reimbursements are received by West Bay, Avy-Altschul Project costs will be promptly reimbursed to West Bay and then Sharon Heights in the order in which they are incurred. Sharon Heights shall be exclusively responsible for, and shall promptly remit to West Bay upon demand, all Avy-Altschul Project costs that exceed the amount of any SRF Loan or grant funds.

5. Article 6. – Sharon Heights's Payment Obligations – is hereby amended at Sections 6.01 – Sharon Heights' Payment Obligations – and Section 6.03 – Service Fee Payments – to read as follows:

6.01 Sharon Heights' Payment Obligations.

Sharon Heights' Payment Obligations shall include all West Bay project costs incurred after December 2, 2015, associated with the planning, permitting, design, and construction of the Project Facilities as indicated in Exhibit L-Initial Project Cost Estimate Budget, which will be replaced with a Final Project Cost Estimate when the design build agreement is finalized. These costs will be financed by West Bay through a State SRF loan provided, however, that Sharon Heights will be responsible for any and all Project Costs that are not financed by the SRF Loan, which shall also include, but are not limited to, all O&M Costs as further described below. Sharon Heights' Payment Obligations shall also include all West Bay costs incurred associated with the land acquisition, planning, permitting, design, and construction of the Avy-Altschul Project. These costs will be financed by West Bay through a State SRF loan provided, however, that Sharon Heights will be responsible for any and all Avy-Altschul Project Costs that are not financed by the SRF Loan or grand funds, which shall also include, but are not limited to, all O&M Costs as further described below.

6.03 Service Fee Payments.

Sharon Heights shall pre-pay the first annual Service Fee Payment to West Bay, and each Service Fee Payment thereafter annually, in ten equal monthly installments, each amounting to ten percent (10%) of the annual Service Fee Payment amount, with the first equal monthly installment due 30 days after the Substantial Completion Date and the last monthly installment of each year due approximately 60 days prior to the annual Service Fee Payment due date (collectively referred to as "Service Fee Payments") so that 100% of the annual Service Fee Payment for any given year has been paid by Sharon Heights and received by West Bay no later than 60 days prior to the date by which West Bay is required to make each annual SRF Loan payment. Sharon Heights shall pre-pay the first annual Avy-Altschul Service Fee Payment to West Bay, and each Avy-Altschul Service Fee Payment thereafter annually, in ten equal monthly installments, each amounting to ten percent (10%) of the annual Avy-Altschul Service Fee Payment amount, with the first equal monthly installment due 30 days after the Substantial Completion Date of the Avy-Altschul Pump Station Project and the last monthly installment of each year due approximately 60 days prior to the annual Avy-Altschul Service Fee Payment due date (collectively referred to as "Avy-Altschul Service Fee Payments") so that 100% of the annual Avy-Altschul Service Fee Payment for any given year has been paid by Sharon Heights and received by West Bay no later than 60 days prior to the date by which West Bay is required to make each annual SRF Loan payment

6. Article 7 – Quantity and Rate of Delivery – is hereby amended as follows:

A. Section 7.01 – Delivery of Recycled Water – is amended to read as follows:

“7.01 Delivery of Recycled Water.

West Bay shall use reasonable efforts to provide Recycled Water to Sharon Heights in accordance with this Agreement and Sharon Heights shall use reasonable efforts to accept and use such Recycled Water as provided herein. The Recycled Water to be delivered under this Agreement will be furnished to Sharon Heights at the Point(s) of Delivery. Pursuant to the terms and conditions set forth in this Agreement, on and after the Delivery Commencement Date,

West Bay shall deliver to Sharon Heights at the Point of Delivery, in the aggregate, up to 400,000 gallons per day (0.4 mgd) of Recycled Water for irrigation purposes calculated and averaged over a 7-day weekly period. The total aggregate annual amount of Recycled Water delivered to Sharon Heights in the first full year of operation pursuant to this Agreement is projected to be approximately between one hundred fifty-two (152) and two hundred (200) acre-feet on an average annual basis. If after the first year, the production is not sufficient to meet this target, the Parties will follow the procedures described in Sections 7.05 (Phase in to Deliver up to 0.4 mgd of Recycled Water) and 7.06 (Process to Meet Targeted Delivery).”

B. Section 7.03 – Curtailment, Interruptions in Delivery and Acceptance of Recycled Water – is amended to read as follows:

“7.03 Curtailment, Interruptions in Delivery and Acceptance of Recycled Water. The Parties acknowledge that West Bay's delivery of Recycled Water and Sharon Heights' ability to take delivery of said Recycled Water may occasionally be interrupted or curtailed due to causes outside of their control, including, but not limited to, Force Majeure Events. Neither Party shall be liable to the other for damages arising out of interruption, reduction, or curtailment of Recycled Water delivery due to Force Majeure Events. However, if, after the first year of operation following the full implementation of the Avy-Altschul Project, the Project Facilities prove incapable of producing the targeted amount of 0.4 mgd of Recycled Water (including, but not limited to, as a result of the source water for the Project Facilities and/or a the original ~~single~~ pump station plus the Avy-Altschul Pump Station proving inadequate to produce the targeted amount of 0.4 mgd of Recycled Water), the Parties will follow the procedures outlined in Sections 7.05 (Phase in to Deliver up to 0.4 mgd of Recycled Water) and 7.06 (Process to Meet Targeted Delivery). West Bay will give reasonable advance notice (ideally no less than ten days' notice, but such period may be reduced as circumstances dictate, such as in the case of an emergency) prior to any such curtailment.”

C. Section 7.05 – Phase in to Deliver up to 0.4 mgd of Recycled Water – is hereby amended to read as follows:

“7.05 Phase in to Deliver up to 0.4 mgd of Recycled Water. The Parties understand that the actual production flows of Recycled Water from the Project Facilities, once the Avy-Altschul Project is completed and operational, constructed, may vary from the estimates set forth in Section 7.01 (Delivery of Recycled Water). Should the Project Facilities prove incapable of producing the targeted amount of 0.4 mgd of Recycled Water as set forth in Section 7.01 (including, but not limited to, as a result of the source water for the Project Facilities and/or a single pump station plus the Avy-Altschul Project proving inadequate to produce the targeted amount of 0.4 mgd of Recycled Water), this Agreement provides for a process for the Parties to consider discretionary actions that the Parties may choose to take in the future (subject to timely compliance with all environmental and permitting requirements, including, but not limited to, the California Environmental Quality Act ("CEQA")) that could result in physical changes to the environment ("Discretionary Actions"). The Discretionary Actions may include the potential development of additional pump stations to divert additional effluent to the Project to meet the 0.4 mgd delivery target. In the event any such Discretionary Action becomes necessary in the future, the Parties will work diligently and in good faith to

formulate an implementation plan that (a) takes into account the subject shortfall in meeting the 0.4 mgd delivery target and Sharon Heights' related operational needs for Recycled Water for irrigation, and the legal obligations of West Bay (including, but not limited to, West Bay's obligations to its various rate payers) and (b) appropriately allocates the associated costs and expenses to those benefitted by any such Discretionary Action(s).

D. Section 7.06 - Process to Meet Targeted Delivery – is hereby amended to read as follows:

Section 7.06. Process to Meet Targeted Delivery.

After the completion of the first full year of operation of the Project Facilities, including the Avy-Altschul Pump Station, during which the Parties will actively monitor delivery rates of Recycled Water from the Project Facilities, if delivery of Recycled Water has not met the 0.4 mgd target, in the aggregate, calculated and averaged over a seven-day weekly period, the Parties will meet during the first quarter of the second year of operation of the Avy-Altschul Pump Station to determine how much additional supply is required to meet such 0.4 mgd target. If the Parties mutually conclude that the targeted amount of 0.4 mgd of Recycled Water cannot be reached and sustained, upon Sharon Heights' written request, the Parties will commence the implementation plan to take additional Discretionary Actions to achieve targeted Recycled Water deliveries. This will include, but not be limited to, each Party promptly bringing such plans to its governing board for consideration and approval.

9. Article 20 – Events of Default – is hereby amended at Section 20.04 – Remedies Upon Sharon Heights Even of Default – to read as follows:

“20.04 Remedies Upon Sharon Heights Event of Default.

Upon occurrence of a Sharon Heights event of default, West Bay may avail itself of any and all available legal or equitable remedies including, but not limited to the Reserve Fund, the Board of Directors Resolution/Assessment Security, and the Springing Lien as set forth in section 4.03(8).

10. Exhibit E – Effluent Sources – is hereby amended by the Addition of Exhibit E-1 – Avy-Altschul Effluent Sources, attached hereto and incorporated herein by reference.

11. Except as amended by this Amendment No. 1, all terms and conditions in the LTA shall remain in full force and effect.

IN WITNESS WHEREOF, the duly authorized representatives of the Parties have executed this Amendment No. 1.

“SHARON HEIGHTS”

Sharon Heights Golf and Country Club

Dated: _____, 2023

By: _____
[name], President

“WEST BAY”

West Bay Sanitary District

Dated: _____, 2023

By: _____
Sergio Ramirez, General Manager

Approved as to form:

Approved as to form:

Anthony P. Condotti
West Bay General Counsel

Allison Schutte
Attorney for SHGCC

THIS PAGE LEFT INTENTIONALLY BLANK



**WEST BAY SANITARY DISTRICT
AGENDA ITEM 6**

To: Board of Directors

From: Fariborz Heydari, P.E. Project Manager

Subject: Consider Awarding the Avy-Altschul Pump Station Project to Casey Construction, Inc.

Background

In agreement with Sharon Heights Golf and Country Club (SHGCC), the District Board approved the design of a small pump station near the intersection of Avy Avenue and Altschul Avenue in Menlo Park that would divert wastewater to the SHGCC Recycled Water Facility to create additional recycled water. This pump station was envisioned as a simplex pump station (one pump).

The pump station was designed and sited on Los Lomas Elementary School District property in a new easement that abuts against an existing sanitary sewer easement through the same property. Gravity sewer mains diverting wastewater to this pump station were designed from the intersection of Avy and Altschul to the new pump station. The pump station discharges into a previously constructed forcemain pipe in Altschul Avenue and Sharon Road. This forcemain discharges into a gravity pipeline at the intersection of Sharon Road and Eastridge Avenue and ultimately drains to the main diversion pump station near the intersection of Vine Street and Sand Hill Road, where it is then pumped to the SHGCC Recycled Water Facility for treatment.

The District Board authorized the General Manager to call for bids on the project on March 22, 2022. Three construction companies submitted bids for the project. The anticipated construction cost for this project was \$950,000.

Analysis

The bid opening for this project was on May 16, 2023, at 2:00 PM. The District received a total of three (3) bids, which were as follows:

<u>Bidder</u>	<u>City</u>	<u>Bid Total</u>
Casey Construction	Redwood City	\$894,795.50
Anderson Pacific Engineering	Santa Clara	\$1,136,749.00
JMB Construction, Inc.	San Francisco	\$1,232,636.00

It is understood that the project shall be awarded to the lowest responsible bidder.

Fiscal Impact

SHGCC has committed to funding the Avy-Altschul Pump Station Project through a Sharon Heights Golf and Country Club Recycled Water Facility - Long Term Agreement Amendment No. 1. The District applied for a loan from the State Water Resources Control Board (SWRCB) State Revolving Fund (SRF) to design and construct the pump station. The SWRCB awarded the project \$950,000.00 including \$300,000.00 in State grants. There is no fiscal impact to the District's General Fund as the SRF loan will be repaid by SHGCC.

Environmental Review

A Categorical Exemption was filed for this project on January 18, 2022. Reasons for exemption include the project consisting of construction and location of limited numbers of new, small facilities or structures; installation of small new equipment and facilities in small structures; and the conversion of existing small structures from one use to another where only minor modifications are made in the exterior of the structure. The Project would have a limited disturbance area and minimal aboveground components, and thus would be considered a small facility.

An environmental checklist was prepared for the Project, which documents that the Project would not trigger any exceptions to a categorical exemption (i.e., would not impact scenic highways, is not located on a hazardous waste site, would not impact a historical resource, and would not have a significant impact due to its location, cumulative impacts, or other unusual circumstances). Thus, the Project is exempt under State CEQA Guidelines Sec. 15303.

Recommendation

The Project Manager recommends the District Board of Directors authorize the General Manager to award the Avy-Altschul Pump Station Project to Casey Construction, Inc. of Redwood City, based on Casey Construction being the lowest bidder.

Attachment: Resolution & Recorded CEQA Notice of Exemption and Resolution NO. 2270 (2022)

RESOLUTION NO. _____(2023)

**RESOLUTION AWARDING A CONSTRUCTION CONTRACT FOR THE AVY
ALTSCHUL PUMP STATION PROJECT TO CASEY CONSTRUCTION, INC.**

WHEREAS, The Avy Altschul Pump Station Project plans and specifications were prepared by Freyer & Laureta, Inc. of San Francisco, California, and

WHEREAS, Casey Construction, Inc. is the lowest bidder for the project, and

WHEREAS, There was no informality in Casey Construction, Inc.'s bid package,
and

WHEREAS, Casey Construction, Inc.'s base bid amount was \$894,795.50, and

WHEREAS, this was the lowest responsible base bid, and

WHEREAS, Based on available funds, that the Bid be awarded to Casey Construction, Inc. for \$894,795.50, and

WHEREAS, The total project cost, if awarded to Casey Construction, Inc. with contingencies and construction support services is estimated at \$950,000.00; and

WHEREAS, The District applied for a loan from the State Water Resources Control Board (SWRCB) State Revolving Fund (SRF) to design and construct the pump station, the SWRCB awarded the project \$950,000.00 including \$300,000.00 in State grants, there will be no fiscal impact to the District's General Fund as the SRF loan will be repaid by Sharon Heights Golf and Country Club (SHGCC).

NOW, THEREFORE, BE IT RESOLVED that the District Board of the West Bay Sanitary District, County of San Mateo, State of California, does hereby award a construction contract to Casey Construction, Inc. in the amount of \$894,795.50 for the Avy Altschul Pump Station Project and authorizes the General Manager to execute the construction contract.

PASSED AND ADOPTED by the District Board of the West Bay Sanitary District at a regular meeting thereof held on the 24th day of May, 2023, by the following votes:

Ayes:

Noes:

Absent:

Abstain:

President of the District Board of the
West Bay Sanitary District of San
Mateo County, State of California

Attest:

Secretary of the District Board of the
West Bay Sanitary District of San Mateo
County, State of California

To: Office of Planning and Research
P.O. Box 3044, Room 113
Sacramento, CA 95812-3044

From: West Bay Sanitary District
500 Laurel Street
Menlo Park CA 94025

To: San Mateo County Clerk
Attention Special Services
555 County Center, First Floor
Redwood City, CA 94063

FILED ENDORSED
IN THE OFFICE OF THE
COUNTY CLERK RECORDER
SAN MATEO COUNTY CALIF

JAN 18 2022

Project Title: Avy Altschul Pump Station Project

MARK CHURCH, County Clerk
By DIANA SHIRON
Deputy Clerk

Project Location – Specific: 1011 Altschul Avenue and Altschul Avenue right-of-way

Project Location – City: Menlo Park

Project Location – County: San Mateo

Description of Project: West Bay Sanitary District (WBSD) is proposing construction and operation of the Avy Altschul Pump Station Project to route additional wastewater flows (approximately 98,000 gallons of wastewater per day) to WBSD's Sharon Heights Water Reclamation Plant to meet existing recycled water demands and offset potable water currently used for irrigation. The pump station would be located on Las Lomas Elementary School District property along Altschul Avenue. The pump station would encompass approximately 210 square feet and would include a wet well, 10 horsepower pump, valve vault, motor control center, and new fencing and an access gate. The fencing, access gate, and motor control center would protrude above the ground, with the remaining facilities located below ground. Approximately 150 linear feet of new pipelines would be constructed in Altschul Avenue to connect the pump station to the existing sewer and force main. Three new sanitary sewer manholes would also be constructed at points along the sewer pipeline. A new Pacific Gas & Electric service would also be installed for the pump station. Construction would include excavation to a depth of approximately 20 feet for the pump station and wet well and 12 feet for pipelines. Construction is anticipated to begin in early summer 2023, and require 30 to 60 days to complete.

Name of Public Agency Approving Project: West Bay Sanitary District

Name of Person or Agency Carrying Out Project: West Bay Sanitary District

Exempt Status:

- Ministerial (Sec. 21080(b)(1)); 15268);
- Declared Emergency (Sec. 21080(b)(3); 15269(a));
- Emergency Project (Sec. 21080(b)(4); 15269(b)(c))
- Categorical Exemption: State CEQA Guidelines Sec. 15303 (New Construction or Conversion of Small Structures)
- Statutory Exempt: State code number: _____

Reasons why Project is Exempt:

Class 3 (New Construction or Conversion of Small Structures) consists of construction and location of limited numbers of new, small facilities or structures; installation of small new equipment and facilities in small structures; and the conversion of existing small structures from one use to another where only minor modifications are made in the exterior of the

structure. The Project would have a limited disturbance area and minimal aboveground components, and thus would be considered a small facility. An environmental checklist was prepared for the Project, which documents that the Project would not trigger any exceptions to a categorical exemption (i.e., would not impact scenic highways, is not located on a hazardous waste site, would not impact a historical resource, and would not have a significant impact due to its location, cumulative impacts, or other unusual circumstances). Thus, the Project is exempt under State CEQA Guidelines Sec. 15303.

Lead Agency Contact Person: Sergio Ramirez, District Manager, (650) 321-0384



Signature

Date: 1/17/2022 Title: District Manager

RESOLUTION NO. 2270 (2022)

IN THE DISTRICT BOARD OF THE WEST BAY SANITARY DISTRICT
COUNTY OF SAN MATEO, STATE OF CALIFORNIA

BE IT RESOLVED, by the District Board of West Bay Sanitary District, County of San Mateo, State of California, as follows:

ENVIRONMENTAL IMPACT REVIEW

Name of Project: Avy Altschul Pump Station

Location: Avy Avenue & Altschul Avenue, Menlo Park, California

Entity or Person Undertaking Project: West Bay Sanitary District

Determination of the District Board:

The District Board hereby certifies that it has reviewed the Preliminary Review and Notice of Exemption prepared for this project and has considered the contents thereof. The Board finds that this document is adequate for use by the District in its review of the project.

The District Board finds that the following feasible alternatives and/or mitigation measures within its powers, would substantially lessen any significant effects which the project would have on the environment:

N/A

The Board certifies that the Preliminary Review and Notice of Exemption has been prepared and completed in compliance with the California Environmental Quality Act and the State Guidelines.

The Board finds that the project Environmental Impact Report identifies the following significant effects:

N/A

The Board further finds that for each of these significant effects.

N/A Changes or alterations have been required in, or incorporated, into the project which mitigate or avoid the significant environmental effects thereof as identified in the Final EIR.

N/A Such changes or alterations are within the responsibility and jurisdiction of a public agency other than the District. Such changes have been adopted by such other agency or can and should be adopted by such other agency.

N/A Specific economic, social, or other considerations make infeasible the mitigation measures or project alternatives identified in the Final EIR.

Based upon the foregoing, and upon compliance with District regulations and requirements, as applicable, the project is hereby:

 x Approved

 Disapproved

The District Manager of West Bay Sanitary District is directed to prepare a Notice of Exemption pursuant to the provisions of the State Guidelines Implementing the California Environmental Quality Act adopted by Resolution No. 1105 of this District Board. The District Manager is not directed to prepare and file a Statement of Overriding Consideration pertaining to the approval of this project pursuant to the provisions of the same Guidelines.

Passed and adopted by the District Board of West Bay Sanitary District at a regular meeting thereof held on the 12th day of January, 2022, by the following vote:

Ayes: DEHN, WALKER, THIELE-SARDINA, MORITZ, OTTE

Noes: NONE

Abstain: NONE

Absent: NONE



President of the District Board of the
West Bay Sanitary District of San Mateo
County, State of California

Attest:

Secretary of the District Board of the
West Bay Sanitary District of San Mateo
County, State of California



Serving Our Community Since 1902

500 Laurel Street, Menlo Park, California 94025-3486 (650) 321-0384 (650)321-4265 FAX

SERGIO RAMIREZ
District Manager

In reply, please refer to our

January 17, 2022

I hereby certify the attached to be a true and correct copy of Resolution 2270 (2022), "Avy Altschul Pump Station Environmental Impact Review – Notice of Exemption" adopted by the District Board of the West Bay Sanitary District at the Regular Meeting held on the 22nd day of January, 2022.

Todd Reese
Office & Communications Manager
West Bay Sanitary District



THIS PAGE LEFT INTENTIONALLY BLANK



**WEST BAY SANITARY DISTRICT
AGENDA ITEM 7**

To: Board of Directors

From: Sergio Ramirez, General Manager

**Subject: Consider Establishing Date and Time of Public Hearing to
Consider Annual Tax Roll Sewer Service Charge Report for
Fiscal Year 2023/2024**

Background

District Regulations Article IX Section 900 (10B) require the General Manager file with the Secretary of the District Board on or before July 15th a written report containing a description of each parcel receiving sewer service and the charges to be imposed upon said parcels.

The Secretary of the Board is required to provide notice that the report has been filed and to establish a time and date of Public Hearing to consider any objections or protest to the sewer service charges to be collected on the tax roll for the Fiscal Year 2023/2024.

Recommendation

The General Manager recommends the Board of Directors establish a date and time for a Public Hearing to consider the Annual Tax Roll Sewer Service Charge Report for Fiscal Year 2023/2024 on Wednesday, July 12, 2023 at 7:00pm.

THIS PAGE LEFT INTENTIONALLY BLANK



**WEST BAY SANITARY DISTRICT
AGENDA ITEM 8**

To: Board of Directors

From: Sergio Ramirez, General Manager

Subject: Discussion and Direction on the West Bay and Sharon Heights Recycled Water Facility

A discussion will be held on the Sharon Heights Recycled Water Facility and other events related to the recycled water plant. The Board will have opportunity to provide direction to staff and legal counsel.

Recycled Water Facility Production Data:

2020	Treated	Delivered
August	8.8MG	8.2MG
September	8.2MG	5.1MG
October	7.4MG	4.5MG
November	5MG	1.4MG
December	4.7MG	.55MG
2021	Treated	Delivered
January	4.8MG	.23MG
February	4.4MG	.13MG
March	5.9MG	1.8MG
April	8.5MG	7.6MG
May	9.3.MG	8.2MG
June	9.8MG	8.7MG
July	9.5MG	9.1MG
August	9.4MG	9.0MG
September	9.1MG	6.9MG*
October	7.6MG	2.6MG**
November	5.2MG	0
December	4.7MG	0

Report to the District Board for the Regular Meeting of May 24, 2023

2022	Treated	Delivered
January	4.4MG	97,000 gallons
February	4.4MG	1.5MG
March	6.6MG	3.5MG
April	7.6MG	3.8MG
May	9.2MG	7.4MG
June	9.8MG	8.7MG
July	9.6MG	8.1MG
August	9.2MG	8.1MG
September	8.6MG	6.7MG
October	7.9MG	4.6MG
November	5.9MG	310,000 gallons
December	5.4MG	154,690 gallons

2023	Treated	Delivered
January	5MG	0 gallons
February	3.3MG	0 gallons
March	3.5MG	0 gallons
April	4.9MG	0 gallons

* Sharon Heights substantially tapered off their water usage for September which is the reason for the large discrepancy between treated and delivered.

** Treatment was reduced in the second half of the month. Rain in late October and an irrigation equipment malfunctions caused water delivery to decrease.

The following is a disclosure statement required for any document, written report or brochure prepared in whole or in part pursuant to the Finance Agreement with the State Water Resources Control Board for the West Bay Sanitary District Recycled Water Project - Sharon Heights: Funding for this project has been provided in full or in part through an agreement with the State Water Resources Control Board. California's Clean Water State Revolving Fund is capitalized through a variety of funding sources, including grants from the United States Environmental Protection Agency and state bond proceeds. The contents of this document do not necessarily reflect the views and policies of the foregoing, nor does mention of trade names or commercial products constitute endorsement or recommendation for use.



**WEST BAY SANITARY DISTRICT
AGENDA ITEM 9**

To:*Board of Directors*

From:*Sergio Ramirez, General Manager*

Subject:*Discussion and Direction on the Bayfront Recycled Water Project
and Status Update*

A discussion will be held on the District's Bayfront Recycled Water Projects and other events related to the recycled water projects including financing, environmental review, design/build issues and grant applications.

The Board will have the opportunity to provide direction to staff and general counsel.

THIS PAGE LEFT INTENTIONALLY BLANK



**WEST BAY SANITARY DISTRICT
AGENDA ITEM 10**

To: Board of Directors

From: Sergio Ramirez, General Manager

Subject: Report and Discussion on South Bayside Waste Management Authority (SBWMA)

The District's representative to South Bayside Waste Management Authority (SBWMA), President Fran Dehn, will report on any pertinent items regarding SBWMA business.

THIS PAGE LEFT INTENTIONALLY BLANK



**WEST BAY SANITARY DISTRICT
AGENDA ITEM 11**

To:*Board of Directors*

From:*Sergio Ramirez, General Manager*

Subject:*Report and Discussion on Silicon Valley Clean Water (SVCW)
Plant*

The District's representative to Silicon Valley Clean Water (SVCW), Commissioner George Otte, will report on pertinent items regarding SVCW Operations, CIP and Finance.

THIS PAGE LEFT INTENTIONALLY BLANK