



*1902 - Serving Our Community for over 120 Years - 2024*

**WEST BAY SANITARY DISTRICT  
AGENDA OF BUSINESS**

**REGULAR MEETING OF THE DISTRICT BOARD  
WEDNESDAY, FEBRUARY 14, 2024 AT 7:00 P.M.  
RONALD W. SHEPHERD ADMINISTRATION BUILDING,  
500 LAUREL STREET, MENLO PARK, CALIFORNIA 94025**

**Board Members**

Fran Dehn, President  
David Walker, Secretary  
Roy Thiele-Sardiña, Treasurer  
Edward P. Moritz, Member  
George Otte, Member

**General Manager**

Sergio Ramirez

**District General Counsel**

Anthony Condotti, Esq.

**AGENDA OF BUSINESS**

To participate by telephone or Zoom meeting, public comments can be made by joining Zoom meeting at:

<https://us06web.zoom.us/j/89402579333?pwd=BPO1PzbmClGugFhjlG08Qx5nvUplnO.1>

Meeting ID: 894 0257 9333 Passcode: 054641

1. Call to Order and Roll Call
2. Communications from the Public
3. Consent Calendar

*Matters listed under this item are considered routine and will be enacted by one motion. The motion, seconds, and vote are applicable to any included resolutions and recorded accordingly. There will be no separate discussion of these items unless specifically requested by a member of the Board.*

  - A. Approval of Minutes for Regular meeting January 24, 2024 Pg. 3A-1
  - B. Approval of the Financial Activity Report Authorizing Payment of Certain Bills and Salaries and Consideration of Other Financial Matters through January 31, 2024 Pg. 3C-1
  - C. WBSD Operations and Maintenance Report – January 2024 Pg. 3D-1
  - D. Town of Los Altos Hills Operations and Maintenance Report for Work Performed by WBSD – January 2024 Pg. 3E-1
  - E. Town of Woodside Operations and Maintenance Report for Work Performed by WBSD – January 2024 Pg. 3F-1
  - F. Consideration Authorizing the General Manager to Execute the Quitclaim Deed to a Portion of a Sanitary Sewer Easement from West Bay Sanitary District to Pacific Peninsula Group, of 358 Walsh Road, Town of Atherton, California Pg. 3F-1
  - G. Consider Accepting Sewer Facilities Constructed Pursuant to Class 3 Sewer Permit No. 1624 for the Sewer Realignment for 358 Walsh Road, Town of Atherton, California Pg. 3G-1
4. General Manager's Report Pg. 4-1

5. Workshop and Discussion on the Sewer Service Charge Rate Study for Fiscal Year 2024/25  
Pg. 5-1
6. Authorize the General Manager to Purchase a Mini Excavator Pg. 16-1
7. Discussion and Direction on the West Bay and Sharon Heights Recycled Water Facility Pg. 7-1
8. Discussion and Direction on Bayfront Recycled Water Project and Status Update Pg. 8-1
9. Report, Discussion, and Direction on South Bayside Waste Management Authority (SBWMA)  
including the Solid Waste Franchise Re-Assignment Pg. 9-1
10. Report and Discussion on Silicon Valley Clean Water (SVCW) Plant Pg. 10-1
11. Closed Session
  - A. CONFERENCE WITH LABOR NEGOTIATORS  
(Pursuant to Cal. Govt. Code §54957.6) Agency designated representatives: General  
Manager, General Counsel, IEDA  
Employee Organization: Exempt Employees, Unrepresented Employees, & Teamsters  
Local 350
12. Comments or Reports from Members of the District Board and Consider Items to be Placed on  
Future Agenda
13. Adjournment

The West Bay Sanitary District does not discriminate against persons with disabilities. Upon request, the agenda and agenda packet can be provided in a format to accommodate special needs. If you require a copy of the agenda or related materials in an alternative format to accommodate a disability, or if you wish to attend this public meeting and will require special assistance or other special equipment, please call the District at (650) 321-0384 at least five days in advance and we will make every reasonable attempt to provide such an accommodation.



*1902 - Serving Our Community for over 120 Years - 2024*

**WEST BAY SANITARY DISTRICT  
MINUTES OF THE REGULAR MEETING OF THE DISTRICT BOARD  
WEDNESDAY, JANUARY 24, 2024 AT 7:00 P.M.**

**1. Call to Order**

President Dehn called the meeting to order at 7:00 PM

**Roll Call**

BOARD MEMBERS PRESENT: President Dehn, Secretary Walker, Treasurer Thiele-Sardiña, Director Moritz, Director Otte

BOARD MEMBERS ABSENT: None

STAFF MEMBERS PRESENT: Ramirez, Fisher, Hulsmann, Ladesma, Heydari.  
Condotti by Zoom

Others Present: None

**2. Communications from the Public: None.**

**3. Closed Session**

Entered closed session at 7:02 p.m. Left closed session at 8:02 p.m.

A. CONFERENCE WITH LABOR NEGOTIATORS  
(Pursuant to Cal. Govt. Code §54957.6) Agency designated representatives:  
General Manager, General Counsel, IEDA  
Employee Organization: Exempt Employees, Unrepresented Employees, &  
Teamsters Local 350

Reportable action: None.

**4. Consent Calendar**

**CONSIDERATION OF ITEM(S) REMOVED FROM THE CONSENT CALENDAR**

Discussion/Comments: None.

A. Approval of Minutes for Regular meeting January 10, 2024 Pg. 4A-1  
Motion to Approve by: Thiele-Sardiña 2<sup>nd</sup> by: Moritz Vote: AYE: 5 NAY: 0 Abstain: 0

**5. General Manager's Report**

Discussion/Comments: General Manager Ramirez reported the CIP to replace the 36" sewer trunk pipeline will begin in March of this year. He also reported the Pump Facility Supervisor will present on the STEP/Grinder lights and buzzard installation at the Feb. 28<sup>th</sup> Regular Board Meeting. He continued to report the sewer rates workshop will be held during the February 14<sup>th</sup> Regular Board Meeting. He also reported the Willow Pump Station Project and Point Repair Phase 2 Project will be uploaded to BidNet Direct the new online bidding platform. He continued to report the LAFCo hearing with East Palo Alto Sanitary District will be held on February 7<sup>th</sup> at 2:30pm. The next regular meetings are scheduled for February 14<sup>th</sup> and February 28<sup>th</sup>. The complete General Manager's written report is in the January 24<sup>th</sup>, 2024 agenda packet.

**6. Discussion and Direction on Software as a Service (SaaS) Implementation and Annual Maintenance Fees**

Discussion/Comments: General Manager Ramirez presented to the Board the District's Software as a Service (SaaS) implementation and annual maintenance fees.

**7. Discussion and Direction on the Revised Master Plan Capital Improvement Program List**

Discussion/Comments: General Manager Ramirez presented a revised Master Plan capital improvement program list to the Board. The revised list includes approximately \$10 million to repair and replace the High Frequency Preventative Maintenance pipeline segments.

**8. Consider Approving District Treasury Report Second Quarter FY 2023-24**

Motion to Approve by: Walker 2<sup>nd</sup> by: Otte Vote: AYE: 5 NAY: 0 Abstain: 0

Discussion/Comments: General Manager Ramirez reported on District funds which include Cash Equivalent Accounts, Investment Accounts, PARS Trust, and SHGCC SRF loan deposit.

**9. Consider Adopting Resolution Approving Master Fee Schedule (2024)**

Motion to Approve by: Walker 2<sup>nd</sup> by: Moritz Vote: AYE: 5 NAY: 0 Abstain: 0

Discussion/Comments: General Manager Ramirez reported on the addition of a .99 charge per ACH payment transactions to the Master Fee Schedule.

**10. Consider Authorizing the General Manager to Issue the Call for Bids for the District's Capital Improvement Program - Point Repairs Project Phase II (High Frequency Pipeline Replacement and Repairs) Project No. 1767.0 and Appropriate an Additional \$5.7 Million to the Capital Budget for FY2023/24**

Motion to Approve by: Walker 2<sup>nd</sup> by: Moritz Vote: AYE: 5 NAY: 0 Abstain: 0

Discussion/Comments: General Manager Ramirez reported the Board approved \$4.3M in the budget for this project. Staff requested an additional \$5.7M to increase the number of repairs. The request was approved by the full Board.

**11. Establish February 14, 2024, as the Date of a Public Hearing to Consider Amending the Code of General Regulations for Board Member Compensation**

~~Motion to Approve by: \_\_\_\_\_ 2<sup>nd</sup> by: \_\_\_\_\_ Vote: AYE: NAY: Abstain:~~

Discussion/Comments: This item was tabled until after July 2024.

**12. Report and Discussion on Sharon Heights Recycled Water Plant (SHRWP)**

Discussion/Comments: General Manager Ramirez reported the new SHRWP O&M budget was approved for \$671,950. He also reported the plant is currently producing water at the minimum amount.

**13. Discussion and Direction on Bayfront Recycled Water Project and Status Update**

Discussion/Comments: General Manager Ramirez reported the California Governor's revised budget has lowered the project's SRF loan to \$50M and cut the grant amount to \$5M. He also reported Phase 1 of the Levee Improvement Project is complete and the contractor is preparing for Phase 2. Phase 2 is scheduled to begin in September of 2024.

**14. Report, Discussion and Direction on South Bayside Waste Management Authority (SBWMA) including Solid Waste Franchise Re-Assignment**

Discussion/Comments: None.

**15. Report, Discussion & Direction on Silicon Valley Clean Water (SVCW) and Discussion on SVCW CIP Program and Financing**

Discussion/Comments: None.

**16. Closed Session**

Entered closed session at 9:05 p.m. Left closed session at 9:21 p.m.

A. PUBLIC EMPLOYEE PERFORMANCE EVALUATION/CONF. WITH LABOR NEGOTIATORS

Agency designated representatives: Board President/Legal Counsel

Unrepresented employee: General Manager

Reportable action: None.

**17. Comments or Reports from Members of the District Board and Consider Items to be Placed on Future Agenda**

Discussion/Comments: None.

**18. Adjournment Time:** The meeting was adjourned at 9:22 PM

THIS PAGE LEFT INTENTIONALLY BLANK



**WEST BAY SANITARY DISTRICT**  
**Financial Activity Report**  
**January 2024**

**Date:** February 14, 2024

**To:** Board of Directors

**From:** Annette Bergeron, Personnel & Accounting Specialist  
 Debra Fisher, Finance Manager

**Subject:** Approve Monthly Financial Activity Report

**Financial Activity for the month of January 2024.**

**Receipt Summary:**

Commercial Deposits	158,642.35
Deposits in Transit/(Prior Period)	(1,161.06)
Returned Checks	0.00
Credit Cards	10,944.70
Franchise Fees	327,190.30
San Mateo County [Tax Roll]	0.00
Other Receipts	122,892.23
Transfers	25,950,000.00
<b>Total Receipts</b>	<b><u><u>26,568,508.52</u></u></b>

**Withdrawal Summary**

Total Checks	4,176,109.21
Total Corp Cards	8,765.01
Total Bank Wires/ACHs	2,169,703.13
<b>External Withdrawals</b>	<b>6,354,577.35</b>
Total Internal Bank Transfers	20,000,000.00
<b>Total Withdrawals</b>	<b><u><u>26,354,577.35</u></u></b>

**Fund Expenditure Summary by Budget Category**

100	Operations	21,010,938.80
200	Capital	3,541,179.23
300	Solid Waste	1,260.00
500	Recycled Water	197,332.31
800	Silicon Valley Clean Water	1,603,867.01
<b>Expenditures by Fund</b>		<b><u><u>26,354,577.35</u></u></b>

The transactions listed for November comprise multiple District checking accounts. The District separated payroll expenditures into a separate account to insulate employees from possible risk. On October 30, 2023, the District opened a new Operating account.

Presented to West Bay Sanitary District Board of Directors for review and approval.

President \_\_\_\_\_

Secretary \_\_\_\_\_

**Investment Portfolios**

There are currently five separate investment reserves maintained to support the goals of the District, along with reserves held in LAIF, the Vehicle & Equipment Reserve held in a money market account, and the restricted Pension Trust and Recycled Water State Revolving Fund (SRF) Reserves. Annual contributions are made in accordance with the Board approved budget and periodically evaluated.

<b><u>Reserve Account</u></b>	<b><u>Originated</u></b>	<b><u>Target Balance</u></b>	<b><u>Balance 1/31/24</u></b>	<b><u>Target</u></b>
Operating Reserve	11/26/2014	\$14 million	\$14,024,468	Achieved
Rate Stabilization Reserve	10/30/2015	\$10 million	\$10,982,520	Achieved
Treatment Plant Reserve	8/1/2021	\$12 million	\$12,388,177	Achieved
Capital Project Reserve	11/26/2014	\$8 million	\$28,731,230	Achieved **
Emergency Capital Reserve	10/19/2010	\$6 million	\$6,532,095	Achieved
Recycled Water Cash Flow	11/18/2016	\$8 million	\$6,312,023	Unfulfilled *
Recycled Water SRF Reserve	3/1/2018	\$1.46 million	\$1,518,626	Achieved
Vehicle & Equipment Reserve	8/18/2011	\$1 million	\$1,005,310	Achieved

\* Some funds held in LAIF for current use.

\*\* Capital Budget funds of \$20 million invested in short-term treasuries to increase yields until funds needed for projects.

Excess funds over the current monthly expenditures are held in Local Agency Investment Fund (LAIF), which are equivalent to cash and may earn higher yields without a long-term commitment. Operating Reserves, customer deposits, current capital projects, and Solid Waste Funds are held in LAIF.

<b><u>Investments by Type</u></b>	<b><u>Balance 1/31/24</u></b>
Local Agency Investment Fund (LAIF)	16,195,016
Unrestricted Reserves	
Investment Portfolios	\$78,970,513
Money Market Account	\$1,005,310
Restricted Reserves	
Recycled Water SRF Reserve	\$1,518,626
Public Agency Retirement Services (PARS)	847,168 **
** Balance as of 12/31/23	



**West Bay Sanitary District  
Receipts  
January 2024**

RECEIPT NUMBER	RECEIPT DATE	DESCRIPTION	AMOUNT
463357	1/2/2024	James Momtazee: 280 Nathorst Ave, PV,SSC FY 2023-24	1,306.00
463358	1/2/2024	Void CR	0.00
463359	1/3/2024	Bayshore Plumbers: 330 Ravenswood Ave, MP, Permit	690.00
463360	1/4/2024	Genaro Morales: 528 Berkeley Ave, MP, Permit	485.10
463361	1/3/2024	WBSD: Transfer LAIF to BMO Ops Acct.	4,250,000.00
463362	1/3/2024	WBSD: Transfer LAIF to BMO PR Acct.	500,000.00
463363	1/4/2024	WBSD: Transfer LAIF to BMO Ops Acct.	20,000,000.00
463364	1/5/2024	Discount Plumbing & Rooter: 890 Partridge Ave, MP, Permit	490.00
463365	1/8/2024	Bayshore Plumbers: 284 Greenoaks Dr, ATH, Void	0.00
463366	1/8/2024	Discount Plumbing Inc.: 308 Princeton Road, MP, Permit	490.00
463367	1/8/2024	OHC of California, A Med Corp: Refund - Overpayment	33.00
463368	1/9/2024	BMO: Service Charge Refund 12/2023	163.75
463369	1/9/2024	BMO: Service Charge Refund 12/2023	227.70
463370	1/10/2024	SHGCC: O&M 1/2024 & SRF Loan Installment# 10	110,664.09
463371	1/11/2024	Almo Construction Inc: 575 Olive St, MP, Permit	222.00
463372	1/12/2024	John Urbanowicz: 4111 Alpine Rd, PV, 18234045,SSC FY 2023-24	1,113.00
463373	1/12/2024	John Eric Alburger: 3 William Ct., MP, ADU Conn & Permits	5,444.40
463374	1/16/2024	Hach: Refund 1/2024	850.00
463375	1/16/2024	Bayshore Plumbers: 19 Laburnum Rd, Ath, Permit	490.00
463376	1/17/2024	Distinct Builders: 2061 Manzanita Ave, MP, Permit	490.00
463377	1/17/2024	Paravati Construction Inc.: 3 Hillbrook Dr, PV, Permit	220.00
463378	1/19/2024	Recology: SW Franchise Fees 12/2023	9,366.30
463379	1/19/2024	Bayshore Plumbers: 1148 Marcussen Dr, MP, Permit	490.00
463380	1/19/2024	Maz Plumbing Under Ground And Sewer Services: 23 Belbrook Wa	490.00
463381	1/22/2024	Arthur Van Hoff Tr: 99 San Mateo Drive, MP, ADU Conn & Permit	6,085.20
463382	1/22/2024	Knockout Plumbing & Repipe, Inc.: 390 Ringwood Ave, MP, Perm	490.00
463383	1/22/2024	L & V Lehmann Trust: 850 Los Trancos Rd, PV,SSC FY 2023-24	1,306.00
463384	1/23/2024	Canning Construction: 211 Oakhurst Ln, MP, Permit	220.00
463385	1/24/2024	Recology: SW Surplus Distribution 2022	317,824.00
463386	1/24/2024	WBSD: Transfer LAIF to Ops Acct	1,200,000.00
463387	1/24/2024	Shoreway Plumbing: 911 Peggy Lane, MP, Permit	110.00
463388	1/24/2024	Bayshore Plumbers: 124 Chester St, MP, Permit	490.00
463389	1/24/2024	Raul Martinez: 4590 Alpine Rd, PV, Permit	720.00
463390	1/24/2024	Town of Los Altos Hills: MSA 11/2023	91,166.00
463391	1/24/2024	Heida Earnest: 175 Los Trancos Circle, PV, SSC FY 2023-24	653.00
463392	1/24/2024	Hamilton Builders, Inc.: 845 San Mateo Dr, MP, Permit	220.00
463393	1/25/2024	Bayshore Plumbers: 2139 Cedar Ave, MP, Permit	490.00
463394	1/25/2024	Preston Pipelines Infrastructure: 100 Terminal Ave, MP,	1,380.00
463395	1/29/2024	SHGCC: O&M 1/2024 Balance Due	11,623.00
463396	1/29/2024	Town of Woodside: MSA 10/1/23-12/31/23	44,745.69
463397	1/29/2024	Rabia Bajwa, Naveed Anward: 1260 Hermosa Way, MP, ADU&Permit	6,085.00
463398	1/30/2024	Sam Mohsenzadegan: 1931 Perry Ave, MP, Permit	220.00
463399	1/31/2024	ARA Rescue Rooter Plumbing: 11 Michaels Way, Ath, Permit	741.60
463400	1/19/2024	BMO: Service Charge Refund 12/2023	213.69
<b>Total Receipts</b>			<b>\$26,568,508.52</b>
Returned Checks			0.00
<b>Net Receipts</b>			<b>\$26,568,508.52</b>

**West Bay Sanitary District  
Financial Activity Report  
Withdrawals  
January 2024**

Check	Date	Payee	Purpose	Amount
71338	1/4/2024	Anderson Pacific	FERRF Levee Improvement Project 1762.0 - 10/2023 & 11/2023	3,291,744.30
71339	1/4/2024	CSRMA C/O Alliant Insurance	Liability Coverage CY 2024	164,495.00
71340	1/4/2024	California Water Service	Water Service - Nov-Dec 2023	60.38
71341	1/4/2024	CaIPERS Longterm Care Program	LTC Withholding 12/16/23-12/31/23	67.27
71342	1/4/2024	Cintas	Uniform Service 12/28/23	1,200.30
71343	1/4/2024	CleanServ Universal Services	Trash Can Liners 12/2023	65.99
71344	1/4/2024	Comcast	Internet - Dec 2023-Jan 2024	621.52
71345	1/4/2024	Core & Main	Couplers & Supplies 12/2023	171.10
71346	1/4/2024	Navia Benefit Solutions	Commuter & FSA Fees12/2023	200.00
71347	1/4/2024	Freyer & Laureta	Point Repair Phase 2 Design 1767.0 10/2023	5,833.75
71348	1/4/2024	Grainger	Misc Parts & Supplies, Small Tools New and Replacement 12/2023	4,077.95
71349	1/4/2024	Gabriel Hernandez	SHRWF Gardening Service 12/2023	300.00
71350	1/4/2024	Instrument Technology Corp.	Repairs to Lateral Camera 11/2023	1,001.97
71351	1/4/2024	City Of Menlo Park - Water Svc	Water Service - Hamilton Ave 11/17/23-12/15/23	58.37
71352	1/4/2024	City Of Menlo Park - Fuel	District Vehicles Fuel 12/2023	6,804.82
71353	1/4/2024	Pacific Gas & Electric	Electric Service - Oct-Dec 2023	21,426.93
71354	1/4/2024	Ponton Industries	Hach Flo-Dar Batteries (8) 10/2023	2,450.00
71355	1/4/2024	Raco Mfg & Eng, Co	Verbatim Alarm Machine 12/2023	2,679.69
71356	1/4/2024	SWRCB	SWRCB Annual Permit Fee - FERF 7/1/23-6/30/24	1,360.00
71357	1/4/2024	Weco Industries	CCTV Repair Oct-Dec 2023	8,053.24
71358	1/4/2024	Woodard & Curran	Bayfront Project Management Services Contract B 10/2023	131,324.75
71359	1/11/2024	Alpha Analytical Laboratories	Daily Coliform Samples - SHGCC RW Facility 12/2023	1,440.00
71360	1/11/2024	CSRMA C/O Alliant Insurance	WC Payroll Audit FY 2022-23	1,263.00
71361	1/11/2024	CaIPERS Longterm Care Program	LTC Withholding 1/1/24-1/15/24	67.27
71362	1/11/2024	Cintas	Uniform Service 1/4/24	1,252.79
71363	1/11/2024	Du-All Safety, LLC	DuAll Safety Maintenance Contract 12/2023	4,590.00
71364	1/11/2024	Navia Benefit Solutions	FSA Contributions PR 01/12/2024	1,025.38
71365	1/11/2024	Freyer & Laureta	Telemetry System, Point Repair,	38,262.50
71366	1/11/2024	Freyer & Laureta	Levee Design, Willow Rd PS Rehab, Stowe Ln PS Replace, & Construction Supp.	123,794.83
71367	1/11/2024	Grainger	Misc Parts & Supplies 1/2024	173.34
71368	1/11/2024	Home Depot Credit Services	Nov-Dec 2023	1,313.94
71369	1/11/2024	Ieda	Consulting Fees 1/2024	814.00
71370	1/11/2024	Kaz & Associates	FERRF Levee Improvements 11/2023	1,750.00
71371	1/11/2024	Mccrometer Inc.	Flo-Dar Maintenance Contract 12/2023	12,993.75
71372	1/11/2024	City Of Menlo Park - Water Svc	Water Service - Nov-Dec 2023	91.23
71373	1/11/2024	Abila	MIP Cloud Subscription 2/4/24-3/3/24	698.35
71374	1/11/2024	Pacific Gas & Electric	Electric Service - Nov-Dec 2023	2,047.90
71375	1/11/2024	Principal Life Insurance	Dental, Vision, Life, AD&D, Disability Ins 01/2024	7,501.02
71376	1/11/2024	Red Wing Shoe Store	Safety Boots - (5) 12/2023	1,182.23
71377	1/11/2024	Samuel M. Rose	Sam Rose Consulting - SOP 1/2024	284.40
71378	1/11/2024	Seekzen Systems	IT Consulting Service 12/2023	475.00
71379	1/11/2024	Sharp Business Systems	Copiers Monthly Lease 1/2024	1,279.93
71380	1/11/2024	TPX Communications	District VoIP & Fiber Service 12/2023	3,271.94
71381	1/11/2024	Teamsters Local No. 350	Union Dues 1/2024	1,088.00
71382	1/11/2024	CentralSquare Technologies	Public Admin Development Services 12/2023	180.00
71383	1/11/2024	Verizon Wireless	Cellular Service - SHRWF Communications 12/2023	65.57
71384	1/11/2024	Vision Communications Co.	Radio Air Time 1/2024	764.15
71385	1/16/2024	Sergio Ramirez	Payroll: YE Department Mgr Compensation 2023	26,128.20
71386	1/17/2024	A-A Lock & Alarm	Padlocks 1/2024	23.95
71387	1/17/2024	Matheson Tri-Gas	Tank Rentals 12/2023	111.95
71388	1/17/2024	Airgas Usa, LLC	Tank Rentals 12/2023	59.38
71389	1/17/2024	Veolia Water North America	Water Service - 1805 Purdue Ave 12/2/23-1/1/24	64.55
71390	1/17/2024	Readyrefresh By Nestle	Office Expense - A&G	139.73
71391	1/17/2024	Cintas	Uniform Service 1/10/24	1,243.19
71392	1/17/2024	CPS HR Consulting	HR Consulting Services 10/19/23-11/25/23	97.50
71393	1/17/2024	Fast Response On-Site Testing	Annual Fit Test for Crew 1/2024	2,703.36
71394	1/17/2024	Grainger	Small Tools New and Replacement 1/2024	234.03
71395	1/17/2024	Hach Company	HACH pH Probe Replacement - SHRWF Sinking Fund 1/2024	3,412.51
71396	1/17/2024	Napa Auto Parts	Vehicle Parts 1/2024	200.31
71397	1/17/2024	Carrie Nevoli	C.Nevoli 15 year District Anniversary 1/2024	225.00
71398	1/17/2024	PBM	Tools, Shovels and Concrete, Gloves, Shovels 1/2024	590.03
71399	1/17/2024	D&J Gardening	Landscaping 1/2024	400.00
71400	1/17/2024	Recology Peninsula Services	Recology Waste 2 Yard Bin - SHGCC 12/2023	249.39
71401	1/17/2024	Seekzen Systems	VMWare Upgrade & Annual Renewal of Synology Cloud Backup 1/2024	10,675.00
71402	1/17/2024	Justin Kinder	J.Kinder 5 year District Anniversary 1/2024	75.00

**West Bay Sanitary District  
Financial Activity Report**

**Withdrawals  
January 2024**

71403	1/24/2024	Bay Alarm	Alarm System Monitoring 2/1/24-4/30/24	902.70
71404	1/24/2024	Bluebeam, Inc.	BlueBeam Annual Renewal 02/08/2024-02/07/2025	800.00
71405	1/24/2024	Cdw Government	Annual Microsoft Office 365 Subscription Renewal & Visio Software	6,265.14
71406	1/24/2024	CWEA	CWEA Membership Renewal A.Patino 2024	98.00
71407	1/24/2024	California Water Service	Water Service - Dec 2023 - Jan 2024	1,926.93
71408	1/24/2024	Cintas	Uniform Service 10/4/23 & 1/17/24	2,366.32
71409	1/24/2024	Navia Benefit Solutions	FSA Contributions PR 1/26/24	1,179.22
71410	1/24/2024	Lasky Trade Printing	Business Cards - Fariborz H. 5/2023	164.06
71411	1/24/2024	Grainger	Pump Station PPE, Small Tools, Misc Parts & Supplies 1/2024	4,292.46
71412	1/24/2024	John Green	Website Photo Shoot 12/2023	400.00
71413	1/24/2024	Kimball Midwest	Cancellation Ear Muffs, Maintenance Parts Stock, Crimping Dies	2,405.84
71414	1/24/2024	Quadient Leasing USA	Postage Meter Lease 2/10/24-5/9/24	268.37
71415	1/24/2024	R.A. Nosek Investigations	New Hire Background Check - J.Shotwell 1/23/24	315.00
71416	1/24/2024	Pacific Gas & Electric	Electric Service - Dec 2023 - Jan 2024	568.62
71417	1/24/2024	Precise Printing and Mailing	2023 Easement Mailer and Printing 3/2023	2,006.27
71418	1/24/2024	Ranger Pipelines	Bayfront Park Sanitary Sewer Improvement Prj 1761.8 10/2023 & 12/2023	76,993.85
71419	1/24/2024	Redwood General Tire Co	Tire Repair & Purchase 12/2023	2,274.81
71420	1/24/2024	Redwood City Health & Wellness	DOT Physicals - B.Scheidt 1/23/24	85.50
71421	1/24/2024	Signa Mechanical	E-One Grinder Pump Cables 1/2024	2,248.45
71422	1/24/2024	Shape, Inc.	E-One Pump Replacement 1/2024	8,206.25
71423	1/24/2024	Sturdy Fence Company	Rear Fence Repair 1/2024	690.00
71424	1/24/2024	Verizon Wireless	District Cellphones 12/16/23-1/15/24	1,934.75
71425	1/24/2024	Weco Industries	CCTV & Sewer Cleaning Equipment Repairs	9,852.58
71426	1/31/2024	AT&T	Telemetry & Alarms 12/13/23-1/12/24	1,232.17
71427	1/31/2024	Readyrefresh By Nestle	Water Delivery 12/11/23-1/10/24	240.47
71428	1/31/2024	Atchison, Barisone & Condotti	Legal Services 12/2023	11,553.73
71429	1/31/2024	Bay Reprographic	Service Colotrac SmartLF Ci40 Scanner 1/2024	318.00
71430	1/31/2024	Bonny Doon Environmental	STEPS System Parts for Stock and Replacement 1/2024	552.09
71431	1/31/2024	California Water Service	Water Service - Dec 2023 - Jan 2024	109.88
71432	1/31/2024	Calpers Longterm Care Program	LTC Withholding 1/16/24-1/31/24	67.27
71433	1/31/2024	Cintas	Uniform Service 1/24/24	1,200.30
71434	1/31/2024	Comcast	Internet 1/20/24-2/19/24	644.22
71435	1/31/2024	Embarcadero Media Foundation	Almanac News Advertisement & Public Notices	5,740.00
71436	1/31/2024	Fedex	FedEx - WECO 1/22/2024	214.71
71437	1/31/2024	Ford Motor Company	Ford Pro Charging 5y Service Agreement 2024-2028	4,074.00
71438	1/31/2024	Freyer & Laureta	F&L Staff Augmentation 11/2023	4,080.00
71439	1/31/2024	Grainger	Misc Parts & Supplies 1/2024	256.15
71440	1/31/2024	Hach Company	HACH Instrument Calibrations Service Package - SHRWF 1/2024	5,966.00
71441	1/31/2024	Gabriel Hernandez	SHRWF Gardening Service 1/2024	300.00
71442	1/31/2024	Kaz & Associates	FERRF Levee Improvements 12/2023	2,800.00
71443	1/31/2024	City Of Menlo Park - Water Svc	Water Service - Dec 2023 - Jan 2024	510.80
71444	1/31/2024	City Of Menlo Park	2023 Street Resurfacing Project 12/2023	2,420.00
71445	1/31/2024	Pacific Gas & Electric	Electric Service - Dec 2023 - Jan 2024	19,911.37
71446	1/31/2024	Paytrace	Paytrace: Credit Card Processing Fees 12/2023	320.42
71447	1/31/2024	Preferred Alliance	DOT Testing Admin Fees 12/2023	266.76
71448	1/31/2024	Centralsquare Technologies	Online Permitting System 1/2024	315.00
71449	1/31/2024	Uline	Hand Soap Admin 12/2023	381.12
71450	1/31/2024	Underground Republic Water	Pipe Materials, ARC Couplers and Fittings 1/2024	96.57
71451	1/31/2024	Trojan Technologies Group Ulc	Trojan UV Lamp Service/Replacement - SHRWF 10/2023	2,443.50
71452	1/31/2024	V.W. Housen & Associates	Master Plan Update 10/1/23-12/31/23	83,370.42
71453	1/31/2024	Vision Communications Co.	Radio Replacements and Accessories 11/2023	2,178.21
<b>Checks</b>				<b>4,176,109.21</b>

**West Bay Sanitary District  
Financial Activity Report  
Withdrawals  
January 2024**

**Corporate Cards:**

GL	Date	Account Name	Description	Amount
54028	1/19/2024	Commuter Benefits	Fastrak: Commuter Benefit 12/21/23	1,070.00
54063	1/19/2024	Diesel Pump Stations Fuel	Chargepoint: Unit 232 Charging 12/19/23	20.00
54080	1/19/2024	Memberships	Peloton Monthly Subscription & CWEA Membership Renewals	359.00
54091	1/19/2024	Stationary and Office Supplies	Costco: Office Supplies 12/05/23	606.38
54092	1/19/2024	Periodicals & Printer Supplies	Staples: Ink 12/10/23	1,165.28
54095	1/19/2024	Postage	Notary Service & SMC Copies of Deeds	62.00
54107	1/19/2024	Personal Protective Equip & Su	Redwood Trading Post: Safety Apparel 12/13/23	329.57
54126	1/19/2024	Safety Training	Safety Recognition Gift Cards	450.00
54132	1/19/2024	Printing Forms & Cards	Postable.Com: December Birthdays 11/27/23	11.85
54134	1/19/2024	Printing Maps	SMC Building: Recorder Copies 12/18/23	50.00
54157	1/19/2024	Building Repairs & Maint.	Lightbulbs.Com: Maintenance Building Lights 12/20/23	158.31
54158	1/19/2024	Computer Software R & M	Duo & Zoom Monthly Subscriptions & QR Generator	198.88
54173	1/19/2024	Dept Training & EE Development	Notary Oath & Staff Recognition Gift Cards	480.09
54174	1/19/2024	Mgmt Conf. & District Meetings	District Meetings	1,197.92
54176	1/19/2024	Business Meetings	Winter Luncheon & Staff Meetings	2,418.97
54191	1/19/2024	Internet	Comcast: SHRWF Internet 12/07/23	186.76
<b>US Bank - CalCards</b>				<b>8,765.01</b>

**Bank Wires/ACH**

Date	Payee	Purpose	Amount
1/2/2024	Nuvei / Paya	Credit Card Processing Fees	288.73
1/2/2024	Navia Benefit Solutions	Commuter Deduction Benefits - January	1,103.60
1/4/2024	SVCW	SVCW Monthly Operating Contribution	596,016.00
1/5/2024	ADP	ADP Fees	296.85
1/8/2024	Neopost	Postage	300.00
1/8/2024	CalPERS	Retirement Contributions PR 12/29/2023	28,068.94
1/11/2024	ADP	Payroll Taxes - Board	755.82
1/11/2024	ADP	Director Fees Dec 2023	4,081.87
1/11/2024	ADP	Payroll Taxes - 1/12/24	48,049.42
1/11/2024	ADP	Employee Payroll - Check Date: 1/12/24	136,853.48
1/11/2024	CalPERS	Health Premiums	74,445.82
1/12/2024	MissionSquare	Deferred Compensation	17,918.88
1/19/2024	ADP	ADP Fees	338.05
1/22/2024	CalPERS	Retirement Contributions PR 1/12/24	29,552.81
1/25/2024	Zions Bank	SVCW 2018 Revenue Bonds	587,291.83
1/25/2024	Zions Bank	SVCW 2021 Revenue Bonds	420,559.18
1/25/2024	Navia Benefit Solutions	Commuter Deduction Benefits - February	1,103.60
1/25/2024	ADP	Payroll Taxes - 1/26/24	41,721.16
1/25/2024	ADP	Employee Payroll - Check Date: 1/12/24	126,405.23
1/26/2024	MissionSquare	Deferred Compensation	24,512.90
1/30/2024	CalPERS	Retirement Contributions PR 1/26/24	29,583.07
1/31/2024	ADP	ADP Fees	302.05
1/31/2024	Nuvei / Paya	Credit Card Processing Fees	153.84
<b>Bank Wires/ACH</b>			<b>2,169,703.13</b>

**Bank Transfers:**

Date	Payee	Purpose	Amount
1/4/2024	WBSD	Transfer to Capital Project Reserve	20,000,000.00
<b>Internal Bank Transfers</b>			<b>20,000,000.00</b>

**Summaries:**

**Withdrawal Summary**

Total Checks	4,176,109.21
Total Corp Card	8,765.01
Total Bank Wires / ACHs	2,169,703.13
Total Internal Bank Transfers	20,000,000.00
<b>Total Withdrawals</b>	<b>26,354,577.35</b>

**West Bay Sanitary District  
Expenditures By Vendor  
7/01/2023 to 01/31/2024**

<b>Withdrawals</b>	<b>Total by Vendor YTD FY 2023-24</b>	<b>Withdrawals January 2024</b>
AAA Fire Protection Services	1,450.00	-
AAA Rentals	9,190.64	-
A-A Lock & Alarm	2,287.90	23.95
Ace Fire Equipment & Service	-	-
Action Towing	337.00	-
Abila	1,433.14	698.35
ADP - Fees	4,939.85	936.95
ADP-Wage Garnishment	-	-
Aerzen USA Corp.	-	-
Airgas Usa, LLC	406.42	59.38
Allied Crane	-	-
The Almanac	420.00	-
Alpha Analytical Laboratories	24,551.25	1,440.00
Angel Ambriz	125.00	-
Anderson Pacific	3,291,744.30	3,291,744.30
Aqua Natural Solutions	2,422.08	-
AT&T	8,432.40	1,232.17
Atchison, Barisone & Condotti	81,413.90	11,553.73
Seth Avila	250.00	-
Aztec Consultants	-	-
BAGG Engineers	21,095.00	-
Backflow Prevention Specialist	-	-
Bank of the West	392.02	-
BMO	484.27	-
Battery Junction Wholesale	1,756.79	-
Bay Alarm	10,653.00	902.70
Bay Area Air Quality Mgmt Dist	18,491.00	-
Bay Area Barricade Service Inc	-	-
Bay Area Paving Co.	997.00	-
Bay Reprographic	318.00	318.00
Bayside Equipment Company	11,689.03	-
Annette Bergeron	340.74	-
Jed M. Beyer	91.54	-
Blackburn Manufacturing Co	-	-
Bluebeam, Inc.	800.00	800.00
Bonny Doon Environmental	1,344.51	552.09
Bosco Oil Inc DBA Valley Oil	-	-
Brilliant Homes, Inc.	9,547.00	-
CA Dept Of Tax & Fee Admin	-	-
CASA	-	-
CA State Disbursement Unit	-	-
CPS HR Consulting	1,680.00	97.50
Calgon Carbon Corporation	-	-
Calif. Labor Law Poster Service	-	-
CA Regional Water Quality	-	-
California State Lands Comm	-	-
California Water Service	16,543.28	2,097.19
CalPERS - Retirement	432,025.57	87,204.82
CalPERS - Health Premiums	468,266.41	74,445.82
CalPERS - Unfunded Accrued Liability	-	-
CalPERS - Actuary Fees	1,050.00	-
CalPERS - 1959 Survivor Billing	-	-
CalPERS Longterm Care Program	941.78	201.81
California Car Sounds	2,039.80	-
Casey Construction	1,272,623.09	-
CDW Government	6,349.58	6,265.14
Center For Hearing Health	680.00	-
CentralSquare Technologies	54,765.88	495.00
Chavan & Associates	7,250.00	-
ChemsearchFE	-	-
Cintas	34,961.25	7,262.90
City of Foster City	567.00	-
City of Menlo Park	2,359.90	2,420.00
City Of Menlo Park - Fuel	49,808.40	6,804.82
City Of Menlo Park - Water Svc	6,192.21	660.40
Clean Earth Environmental	1,675.51	-
Cleanserv Universal Services	6,713.96	65.99
Coast To Coast Trucking School	5,000.00	-
Comcast	4,719.31	1,265.74
The Concept Genie	1,351.25	-
Consolidated Parts	-	-
Core & Main	16,972.12	171.10
Corrosion Protection Solutions	-	-
Heath Cortez	-	-
Costco	60.00	-
CSDA	9,275.00	-
CSRMA c/o Alliant Insurance	350,809.86	165,758.00
CUES	4,709.69	-

**West Bay Sanitary District  
Expenditures By Vendor  
7/01/2023 to 01/31/2024**

<b>Withdrawals</b>	<b>Total by Vendor YTD FY 2023-24</b>	<b>Withdrawals January 2024</b>
Custom Tops, Inc.	6,220.75	-
CWEA	6,178.00	98.00
D&J Gardening	4,200.00	400.00
D & L Supply	3,899.02	-
Dale Scott & Co.	-	-
Daniel Mechanical	-	-
Das Manufacturing, Inc.	-	-
Detection Instruments Corp.	2,448.13	-
Dell Marketing	19,403.82	-
Dewey Pest Control	-	-
Dolphin Graphics	4,254.00	-
Downtown Ford Sales	129,285.38	-
Du-All Safety, LLC	32,953.05	4,590.00
Duke's Root Control, Inc	259,010.16	-
Embarcadero Media Foundation	5,740.00	5,740.00
Employment Development Dept.	-	-
ESRI	-	-
East Bay Municipal Utility	-	-
Ergoworks	-	-
Fast Response On-Site Testing	2,703.36	2,703.36
FedEx	1,253.42	214.71
Fischer Compliance LLC	-	-
Ford Motor Company	4,074.00	4,074.00
Freyer & Laureta	1,064,230.71	171,971.08
Frisch Engineering, Inc.	1,875.00	-
Victor Garcia	246.04	-
Global Equipment, Inc	-	-
Golden Gate Truck Center	461.38	-
Golden State Reprographics LLC	-	-
GoldStreet Design Agency	4,000.00	-
Govconnection, Inc.	-	-
Governmentjobs.Com	4,871.92	-
Grainger	27,264.97	9,033.93
Granite Rock Company	2,934.88	-
John Green	1,175.00	400.00
Quinten Green	-	-
Grundfos CBS Inc.	1,880.00	-
HF&H Consultants	27,175.00	-
H & R Plumbing & Drain	26,600.00	-
Hach Company	26,384.30	9,378.51
Hadronex	47,459.72	-
Harben California	6,688.51	-
Harrington Industrial Plastics	1,147.71	-
Helix Laboratories	2,764.03	-
Gabriel Hernandez	2,400.00	600.00
Hillyard/San Francisco	944.89	-
Home Depot Credit Services	11,410.44	1,313.94
Bob Hulsmann	389.45	-
ICMA	-	-
IEDA	5,698.00	814.00
Innovyze LLC	10,840.00	-
Institute For Local Government	-	-
Instrument Technology Corp.	1,062.13	1,001.97
Interstate Traffic Control	45.94	-
Ironhouse Sanitary District	-	-
Kaz & Associates	7,550.00	4,550.00
Parisa Khorsand	-	-
Kimball Midwest	6,901.70	2,405.84
Justin Kinder	75.00	75.00
Kone Pasadena	1,917.60	-
Las Lomitas Elementary Sd	49,000.00	-
Lasky Trade Printing	164.06	164.06
Leaf Capital Funding	2,824.24	-
Learn It	-	-
Aurora Ledesma	150.00	-
Livermore Auto Group	-	-
Sione Lolohea	-	-
Eric Madrigal	-	-
Mallory Co.	38,139.72	-
Lisandro Marquez	250.00	-
Matheson Tri-Gas	640.46	111.95
Maxx Metals	-	-
McCrometer Inc.	77,962.50	12,993.75
Medco Supply Company	1,518.91	-
Menlo Park Fire Protection	-	-
Menlo Park Hardware Co. #14016	-	-
Mid Peninsula Abstracts	-	-
Mid State Container Sales, Inc	-	-
MiscoWater	2,612.24	-

**West Bay Sanitary District  
Expenditures By Vendor  
7/01/2023 to 01/31/2024**

<b>Withdrawals</b>	<b>Total by Vendor YTD FY 2023-24</b>	<b>Withdrawals January 2024</b>
Mission Clay Products, LLC	5,566.66	-
MissionSquare	203,586.75	42,431.78
Mission Valley Ford	-	-
Morse Hydraulics	1,385.41	-
Motion Industries	-	-
Multiquip Inc	-	-
Municipal Maintenance Equip.	15,367.30	-
Dominic Nanni	-	-
Napa Auto Parts	1,307.60	200.31
Nassco Pacp	-	-
National Auto Fleet Club	-	-
Navia Benefit Solutions	26,314.87	4,611.80
NeoPost	1,200.00	300.00
Carrie Nevoli	225.00	225.00
Carrie Nevoli - Petty Cash	108.32	-
NorCal Materials, Inc.	2,456.18	-
North Bay Pensions	-	-
Nuvei / Paya	457.57	442.57
Occasions, Etc.	250.17	-
Occupational Health Centers	199.00	-
Ogasawara Landscape Maint.	-	-
Omega Industrial Supply	4,968.70	-
Orenco Systems, Inc.	19,844.91	-
Ovivo Usa, LLC	11,171.24	-
Owen Equipment Sales	3,178.73	-
P&F Distributers	1,010.85	-
Paxxo (USA) Inc	-	-
PBM	4,848.39	590.03
Pacific Gas & Electric	217,006.48	43,954.82
Paytrace	5,375.55	320.42
Peninsula Truck Repair	2,145.43	-
Pier 2 Marketing	1,000.00	-
Charles A. Planje	-	-
Ponton Industries	2,450.00	2,450.00
Precise Concrete Sawing, Inc.	2,208.40	-
Precise Printing And Mailing	4,345.91	2,006.27
Precision Engineering	933,530.04	-
Preferred Alliance	1,930.32	266.76
PrimePay Fees	-	-
Principal Life Insurance	50,969.11	7,501.02
Project Ergonomics	1,264.21	-
Quadient Leasing USA	805.11	268.37
Quincy Compressor	3,491.32	-
R.A. Nosek Investigations	625.00	315.00
R.D. Kincaide, Inc.	16,049.56	-
Raco Mfg & Eng, Co	2,679.69	2,679.69
Sergio Ramirez	26,128.20	26,128.20
Ranger Pipelines	174,911.61	76,993.85
Readyrefresh By Nestle	2,823.84	380.20
Recology Peninsula Services	1,745.73	249.39
Red Wing Shoe Store	4,554.98	1,182.23
Redwood City Health & Wellness	341.50	85.50
Redwood General Tire Co	11,400.58	2,274.81
City Of Redwood City	-	-
Todd Reese	62.52	-
Registrar Of Voters	-	-
Rich Voss Trucking	1,245.00	-
Roadsafe Traffic Systems, Inc.	9,220.85	-
Samuel M. Rose	1,409.40	284.40
George Sanchez	300.00	-
SVCW - Monthly Operating Contribution	4,172,112.00	596,016.00
SVCW - Debt Reserve Contribution	-	-
SVCW - 2018 Bonds	1,836,301.05	587,291.83
SVCW - 2021 A&B Bonds	2,728,945.85	420,559.18
SVCW - SRF Debt	506,765.20	-
Silicon Valley Clean Water	1,350.00	-
Chamber San Mateo County	475.00	-
County of San Mateo	(67.00)	-
San Mateo County Assessor	-	-
San Mateo County Tax Collector	1,013.24	-
San Mateo County Health	2,645.78	-
County of San Mateo - LAFCO	21,739.00	-
San Mateo Lawn Mower Shop	412.09	-
County of Santa Clara	-	-
SWRCB	25,191.00	1,360.00
Secretary Of State	40.00	-
Seekzen Systems	23,775.00	11,150.00
Sensera Systems	6,295.00	-
Shape, Inc.	8,206.25	8,206.25
Sharp Business Systems	8,943.58	1,279.93
Siemens Industry, Inc.	2,087.97	-

**West Bay Sanitary District  
Expenditures By Vendor  
7/01/2023 to 01/31/2024**

<b>Withdrawals</b>	<b>Total by Vendor YTD FY 2023-24</b>	<b>Withdrawals January 2024</b>
Signa Mechanical	2,248.45	2,248.45
Sonsray Machinery LLC	4,258.77	-
Spartan Tool	2,968.98	-
SPL Laboratories	-	-
Staples Credit Plan	1,354.53	-
State Board Of Equalization	7,900.00	-
Stevens Creek Quarry	2,037.89	-
Streamline	6,600.00	-
Sturdy Fence Company	690.00	690.00
Sutter EAP	437.00	-
Syneco Systems, Inc.	796.50	-
TPC Training	-	-
TPX Communications	22,784.94	3,271.94
Teamsters Local No. 350	7,338.00	1,088.00
Teletrac Navman US	1,903.72	-
Telstar Instruments, Inc.	-	-
Thomas & Associates	-	-
Total Equipment Of Fremont	5,091.34	-
Town Of Atherton	-	-
Towne Ford	17,383.57	-
Trojan Technologies Group ULC	33,020.18	2,443.50
Uline	2,452.56	381.12
Underground, Inc.	-	-
Underground Republic Water	11,107.09	96.57
Underground Service Alert	14,084.29	-
United Rentals (North America)	1,671.00	-
Univar Solutions USA	5,799.89	-
US Bank - CalCards	65,432.51	8,765.01
U.S. Jetting, LLC.	-	-
US Standard Products Corp	2,984.76	-
V & A Consulting Engineers	28,234.00	-
V.W. Housen & Associates	309,627.45	83,370.42
Valley Heating & Cooling	882.00	-
Valley Power Systems North	566.92	-
Vallombrosa Center	-	-
Veolia Water North America	460.62	64.55
Verizon Wireless	12,810.65	2,000.32
Video Voice Data Communication	-	-
Vision Communications Co.	12,194.87	2,942.36
Weco Industries	40,564.96	17,905.82
The Weed Solution	-	-
West Yost & Associates	23,781.00	-
Western States Tool & Supply	-	-
Western Truck Fabrication, Inc	-	-
Woodard & Curran	526,963.28	131,324.75
Young's Auto Supply Center	288.71	-
Zenon Environmental	-	-
Zip's AW Direct	-	-
Zoll Medical Corporation	1,895.12	-
Cole Erskine	12,769.01	-
Andrew & Bonnie Sterngold	-	-
Rebecca Flynn & Alexander Moissis	9,046.24	-
William F. Kelly	9,046.24	-
Tedd Corman	-	-
Scott Mitic	17,988.30	-
Elizabeth Holmes	42,718.94	-
Craig M. Buschbaum	48,845.85	-
John Ciancutti	52,157.11	-
Martin & Emiko Kim	52,157.11	-
George Tidmarsh & Courtney Moulds	48,845.85	-
<b>Total Vendor Withdrawals</b>	<b>20,819,963.37</b>	<b>5,996,710.37</b>
<b>Wages &amp; Payroll Taxes</b>		
Salaries/Wages - Net Pay	2,103,307.78	263,258.71
Directors Fees - Net Pay	22,473.55	4,081.87
Payroll Taxes	663,521.51	90,526.40
<b>Total Payroll</b>	<b>34,867,244.70</b>	<b>357,866.98</b>
<b>Total External Withdrawals</b>	<b>55,687,208.07</b>	<b>6,354,577.35</b>
<b>WBSD Transfers:</b>		
WBSD LAIF Account	17,700,000.00	-
WBSD Investment Accounts	-	-
Public Agency Retirement Services (PARS)	75,000.00	-
Other Transfers	20,000,000.00	20,000,000.00
<b>Total Transfers</b>	<b>37,775,000.00</b>	<b>20,000,000.00</b>
<b>Total Withdrawals</b>	<b>93,462,208.07</b>	<b>26,354,577.35</b>





**WEST BAY SANITARY DISTRICT  
AGENDA ITEM 3C**

**To: Board of Directors**

**From: Bob Hulsmann, Operations Superintendent**

**Subject: WBSD Operations and Maintenance Report – January 2024**

 <b>Month</b>	<b>Basin PM Pipe Clean-ing</b>	<b>High Freq. PM Pipe Clean-ing</b>	<b>Un-Sche. Pipe Clean- ing</b>	<b>WBSD CCTV Insp.</b>	<b>Pipe Patch Repairs</b>	<b>Open Trench Repairs</b>	<b>Pump Sta. PM</b>	<b>Pump Sta. Unsch. Repairs</b>	<b>SSO</b>	<b>SSO</b>	<b>Service Calls- Unit 208</b>			
	<b>Miles</b>	<b>Miles</b>	<b>Miles</b>	<b>Miles</b>	<b>Qty.</b>	<b>Qty.</b>	<b>Qty.</b>	<b>Qty.</b>	<b>Cat. 1</b>	<b>Cat. 2,3,4</b>	<b>Call Outs</b>	<b>Sch PM</b>	<b>Unsch. PM</b>	<b>USA's</b>
January	13.9	4.4	0.1	2.8	5	12	80	0	0	0	94	13	1	208
February														
<b>Yr to date</b>	<b>13.9</b>	<b>4.4</b>	<b>0.1</b>	<b>2.8</b>	<b>5.0</b>	<b>12.0</b>	<b>80.0</b>	<b>0.0</b>	<b>0.0</b>	<b>0.0</b>	<b>94.0</b>	<b>13.0</b>	<b>1.0</b>	<b>208.0</b>
<b>2024 Goals</b>	<b>120.0</b>	<b>50.0</b>	<b>n/a</b>	<b>45-50</b>	<b>50-65</b>	<b>90</b>	<b>n/a</b>	<b>&lt;10</b>	<b>&lt;</b>	<b>4</b>	<b>n/a</b>	<b>n/a</b>	<b>n/a</b>	<b>n/a</b>
<b>2023 Results</b>	<b>127.7</b>	<b>47.1</b>	<b>8.5</b>	<b>**45.4</b>	<b>52</b>	<b>94</b>	<b>821</b>	<b>0</b>	<b>0</b>	<b>2</b>	<b>832</b>	<b>85</b>	<b>11</b>	<b>3416</b>
2022 Results	120.9	53.6	7.5	**40.3	**92	100	774	0	1	2	858	97	2	3161
2021 Results	*123	*50	8.6	**46	**55	91	834	2	0	4	944	n/a	n/a	2294
2020 Results	134.2	51.0	8.4	29.6	72	85	754	6	0	0	1012	89	5	2362
2019 Results	112.0	48.2	6.9	42.7	60	86	967	6	0	4	1063	75	33	2850
2018 Results	134.2	48.5	7.4	42.1	66	63	1256	6	0	4	1139	134	89	2525

**\* = Including TOW**

**\*\*= Including LAH and TOW**

THIS PAGE LEFT INTENTIONALLY BLANK



**WEST BAY SANITARY DISTRICT  
AGENDA ITEM 3D**

**To: Board of Directors**

**From: Bob Hulsmann, Operations Superintendent**

**Subject: Town of Los Altos Hills - Operations and Maintenance Report for Work Performed by WBSD – January 2024**

	Basin PM Pipe Clean- ing	High Freq. PM Pipe Clean- ing	Un-Sche. Pipe Clean- ing	WBSD CCTV Insp.	Pipe Patch Repairs	Pump Sta. PM	Pump Sta. Unsch. Repairs	SSO	SSO	Service Calls
Month	Miles	Miles	Miles	Miles	Qty.	Qty.	Qty.	Cat. 1	Cat. 2&3s	Call Outs
January-24	1.0	1.3	0.2	1.0	0	4	0	0	0	0
February	1.8	0.3	0.3	0.8	0	4	0	0	0	0
March	0.8	0.9	0.0	1.1	0	4	3	1	0	0
April	0.0	1.6	0.1	1.0	0	4	0	0	0	0
May	0.0	1.8	0.2	1.4	0	5	0	1	0	0
June	0.7	0.5	0.0	1.0	0	4	0	0	0	0
July	0.0	1.3	0.0	0.1	12	4	0	0	0	0
*August 23	1.0	0.8	0.0	0.5	0	4	0	0	0	0
Sept.	0.7	1.0	0.5	0.8	0	4	0	0	0	0
Oct.	0.0	1.3	0.2	0.9	0	4	0	0	0	0
Nov.	0.4	1.4	0.0	1.0	0	4	0	0	0	0
Dec	1.0	1.6	0.0	0.9	0	4	0	0	0	0
<b>** Yr to date</b>	<b>7.4</b>	<b>13.8</b>	<b>1.5</b>	<b>10.5</b>	<b>12.0</b>	<b>49</b>	<b>3</b>	<b>2</b>	<b>0</b>	<b>0</b>
FY23/24Goals	10.6	14.4	n/a	8.1	n/a	52	n/a	n/a	n/a	n/a
* = August- Start of Contract										
	Goal	Total	Remain							
Pipe Cleaning	25	22.7	2.3							
CCTV Inspecti	8.1	10.5	-2.4							

THIS PAGE LEFT INTENTIONALLY BLANK



**WEST BAY SANITARY DISTRICT  
AGENDA ITEM 3E**

**To: Board of Directors**

**From: Bob Hulsmann, Operations Superintendent**

**Subject: Town of Woodside Operations and Maintenance Report for Work Performed by WBSD – January 2024**

---

**Yearly Summary Report**

2/7/2024  
8:08 AM

Dates Between 2/1/2023 and 1/31/2024

Month	Basin PM Pipe Cleaning (miles)	High Freq PM Pipe Cleaning (miles)	Unscheduled Pipe Cleaning (miles)	CCTV Inspection (miles)	Pump Stations Preventive Maintenance Qty	Pump Stations Unscheduled Repairs Qty	SSO Cat 1	SSO Cat 2 & 3	Service Calls Call Outs
January	0.0	0.0	0.0	0.0	0.0	0.0	0.0	0.0	0.0
February	0.00	0.0	0.0	0.0	0.0	0.0	0.0	0.0	0.0
March	0.00	0.3	0.0	0.0	0.0	0.0	0.0	0.0	0.0
April	0.00	0.0	0.0	1.1	0.0	0.0	0.0	0.0	0.0
May	0.00	0.0	0.0	0.0	0.0	0.0	0.0	0.0	0.0
June	0.00	0.3	0.0	0.0	0.0	0.0	0.0	0.0	0.0
July	0.00	0.0	0.0	0.0	0.0	0.0	0.0	0.0	0.0
August	0.00	0.0	0.0	0.0	0.0	0.0	0.0	0.0	0.0
September	0.00	0.3	0.0	0.0	0.0	0.0	0.0	0.0	0.0
October	0.00	0.0	0.0	0.0	0.0	0.0	0.0	0.0	0.0
November	0.00	0.0	0.0	0.0	0.0	0.0	0.0	0.0	0.0
December	4.52	0.0	0.0	0.0	0.0	0.0	0.0	0.0	0.0
Totals	4.52	0.8	0.0	1.1	0.0	0.0	0.0	0.0	0.0

THIS PAGE LEFT INTENTIONALLY BLANK



**WEST BAY SANITARY DISTRICT  
AGENDA ITEM 3F**

**To: Board of Directors**

**From: Fariborz Heydari, P.E., Project Manager**

**Subject: Consideration Authorizing the General Manager to Execute the Quitclaim Deed to a Portion of a Sanitary Sewer Easement from West Bay Sanitary District to Pacific Peninsula Group, of 358 Walsh Road, Town of Atherton, California**

---

Background

The Board issued Class 3 Permit No. 1624 at the Regular Meeting of June 22 for the relocation of 260 feet of existing 6" sewer main within an existing 6' wide sanitary sewer easement with a new 8" sewer main within a new 10' wide sanitary sewer easement to be Grant Deeded to the District. At the Regular Board Meeting of December 13, 2023 the Board accepted the new Grant Deed of Easement through 358 Walsh Road, Atherton.

The new 10' wide easement has been recorded, and in accordance with our agreement with the property owner, Staff now asks that the General Manager be authorized to abandon the portion of the existing 6' wide easement within the property in conflict with the new ADU in the owner's favor.

Recommendation

The Project Manager recommends the Board of Directors Authorize the General Manager to Execute the Quitclaim Deed to a portion of a Sanitary Sewer Easement and adopt the attached Resolution quitclaiming the Deed of Easement.

Attachments: Resolution \_\_\_\_\_ (2024)  
Quitclaim Deed of Easement

**RESOLUTION NO. \_\_\_\_\_ (2024)**

IN THE DISTRICT BOARD OF THE WEST BAY SANITARY DISTRICT

COUNTY OF SAN MATEO, STATE OF CALIFORNIA

\*\*\*\*\*

BE IT RESOLVED that the District Board of the West Bay Sanitary District hereby authorizes the General Manager to Execute the Quitclaim to the attached Deed Easement from West Bay Sanitary District to Pacific Peninsula Group, a California corporation, and

BE IT FURTHER RESOLVED that the General Manager is hereby directed to place the same on record.

\*\*\*\*\*

Passed and adopted by the District Board of the West Bay Sanitary District at a regular meeting thereof held on the 14<sup>th</sup> day of February, 2024, by the following vote:

Ayes:

Noes:

Abstain:

Absent:

---

President of the District Board of the West Bay Sanitary District of San Mateo County, State of California

Attest:

---

Secretary of the District Board of the West Bay Sanitary District of San Mateo County, State of California





**Mail tax statements to: Pacific Peninsula Group, 718 Oak Grove Ave., Menlo Park, CA 94025**

**Date** \_\_\_\_\_

---

**SERGIO RAMIREZ, GENERAL MANAGER**  
**West Bay Sanitary District**

October 6, 2023

**EXHIBIT "A"**

**LEGAL DESCRIPTION  
FOR QUITCLAIM OF SANITARY SEWER EASEMENT  
358 WALSH ROAD, ATHERTON, CA**

A portion of that certain six foot (6.00') wide easement for sanitary sewer purposes lying with the Town of Atherton, County of San Mateo, State of California, as described in the Grant Deed to the Menlo Park Sanitary District, recorded April 23, 1952, in Book 2233 at Page 615 of Official Records in the Office of the Reorder of said County; said portion lying with Lot 6 as shown on that certain Subdivision Map entitled "Hillview Heights", filed for record in said Office of the Recorder on July 30, 1953, in Volume 37 of Maps at Page 20, and being more particularly described as follows:

Beginning at the intersection of the northerly line of said Lot 6 with the centerline of said 6-foot-wide sanitary sewer easement, said intersection lying North 52°03'35" East, 50.28 feet from the northwesterly corner of said Lot 6;

Thence along said easement centerline South 28°21'40" East, 77.19 feet;

Thence South 6°33'40" East, 206.00 feet;

Thence South 9°32'40" East, 6.00 feet to the Point of Terminus;

The sidelines of said 6-foot-wide strip shall be prolonged or shortened so as to terminate in said northerly line of Lot 6.

As shown on Exhibit "B", attached hereto and made a part hereof.

**Description prepared by MacLeod and Associates, Inc.**

  
\_\_\_\_\_  
Daniel G. MacLeod L.S. 5304  
OCTOBER 6, 2023  
\_\_\_\_\_  
Date:

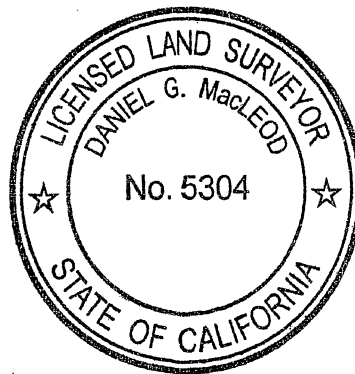





**WEST BAY SANITARY DISTRICT  
AGENDA ITEM 3G**

**To: Board of Directors**

**From: Fariborz Heydari, P.E., Project Manager**

**Subject: Consider Accepting Sewer Facilities Constructed Pursuant to Class 3 Sewer Permit No. 1624 for the Sewer Realignment for 358 Walsh Road, Town of Atherton, California**

---

Background

This permit was issued upon discovery of an easement encroachment from a newly constructed Accessory Dwelling Unit (ADU) at 358 Walsh Road in Town of Atherton (Town.) The ADU's foundation and construction methods damaged the public sewer pipeline. A segment of the existing 6" public sewer main along the southerly side of the property was in conflict with the ADU's foundation and was relocated and replaced with a new 8" sewer main. The new sewer main installed and construction work consisted of approximately 260 feet of 8" sewer main, removing one manhole, and adding a new manhole.

Analysis

The Board issued this Class 3 Permit No. 1624 at the Regular Meeting of June 22, 2022.

The work has been completed, inspected, tested, and approved by staff as being in conformance with District standards. The property owner has submitted a one-year guarantee for the work in the form of a maintenance bond.

Recommendation

The Project Manager recommends that the Board accepts these facilities and directs the General Manager to approve Class 3 Permit No. 1624.

Attachments: Class 3 Permit No. 1624  
Exhibit A: As-Built

# WEST BAY SANITARY DISTRICT

500 Laurel Street  
Menlo Park, California 94025  
(650) 321-0384

Permit Number  
1624

Type \_\_\_\_\_

## APPLICATION FOR CLASS 3 SEWER PERMIT

To the WEST BAY SANITARY DISTRICT:

The undersigned, being the  Owner  Owner's Agent of the property located at

358 Walsh Rd Atherton

does hereby request permission to construct sanitary sewers and related facilities to serve a

Residential  Non-residential Development at said location.

### ENGINEER'S

MacLeod and Associates  
Name

965 Center St. San Carlos, CA 94070  
Address

### CONTRACTOR'S

Pacific Peninsula Group  
Name

718 Oak Grove Ave. Menlo Park  
Address

### OWNER'S

Pacific Peninsula Group  
Name

718 Oak Grove Ave. Menlo Park  
Address

Erica Zabala  
Applicant's Signature

Erica Zabala  
Signed by - Please Print Name

718 Oak Grove Ave. Menlo Park  
Address

Receipt of \$ 0 Application Fee is hereby acknowledged AS flat - 9/29/2022  
Date

Receipt of \$ 0  Cash Deposit or  Performance Bond

Comments Replacing approx 260 ft of sewer main and removing one man hole and adding another.

Approved by the District Board on \_\_\_\_\_

Application approved and permit issued:

**WEST BAY SANITARY DISTRICT**  
**Sergio Ramirez, General Manager**

Date \_\_\_\_\_

By \_\_\_\_\_

Final Acceptance by the District Board on \_\_\_\_\_

(SEE PERMIT CONDITIONS ON REVERSE)

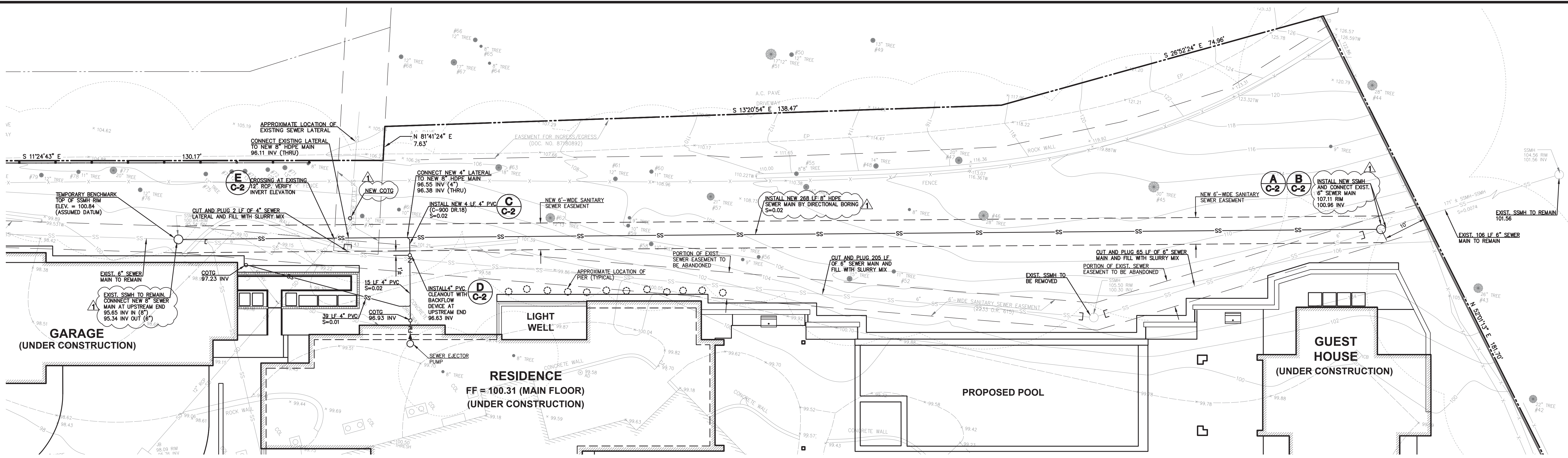

**LEGEND:**

—	PROPERTY LINE
—	AC PAVE
—	COTG
—	EP
—	INV
—	P.U.E.
—	SSMH
—	TW
●	12" TREE
—SS—	SANITARY SEWER LINE
—SD—	STORM DRAIN LINE
—	ASPHALT CONCRETE PAVEMENT
—	CLEANOUT TO GRADE
—	EDGE OF PAVEMENT
—	INVERT
—	PUBLIC UTILITY EASEMENT
—	SANITARY SEWER MANHOLE
—	TOP OF WALL
—	TREE W/ SIZE

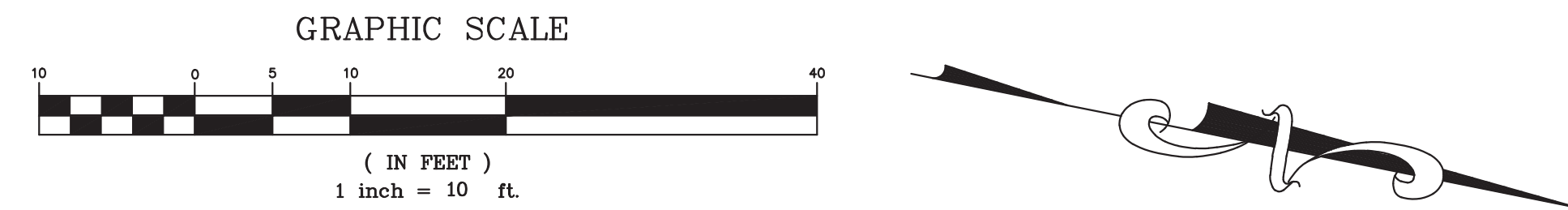

**UTILITY NOTE:**  
 THE UTILITIES EXISTING ON THE SURFACE AND SHOWN ON THIS DRAWING HAVE BEEN LOCATED BY FIELD SURVEY. ALL UNDERGROUND UTILITIES SHOWN ON THIS DRAWING ARE FROM RECORDS OF THE VARIOUS UTILITY COMPANIES AND THE SURVEYOR/ENGINEER DOES NOT ASSUME RESPONSIBILITY FOR THEIR COMPLETENESS, INDICATED LOCATION, OR SIZE. RECORD UTILITY LOCATION SHOULD BE CONFIRMED BY EXPOSING THE UTILITY.

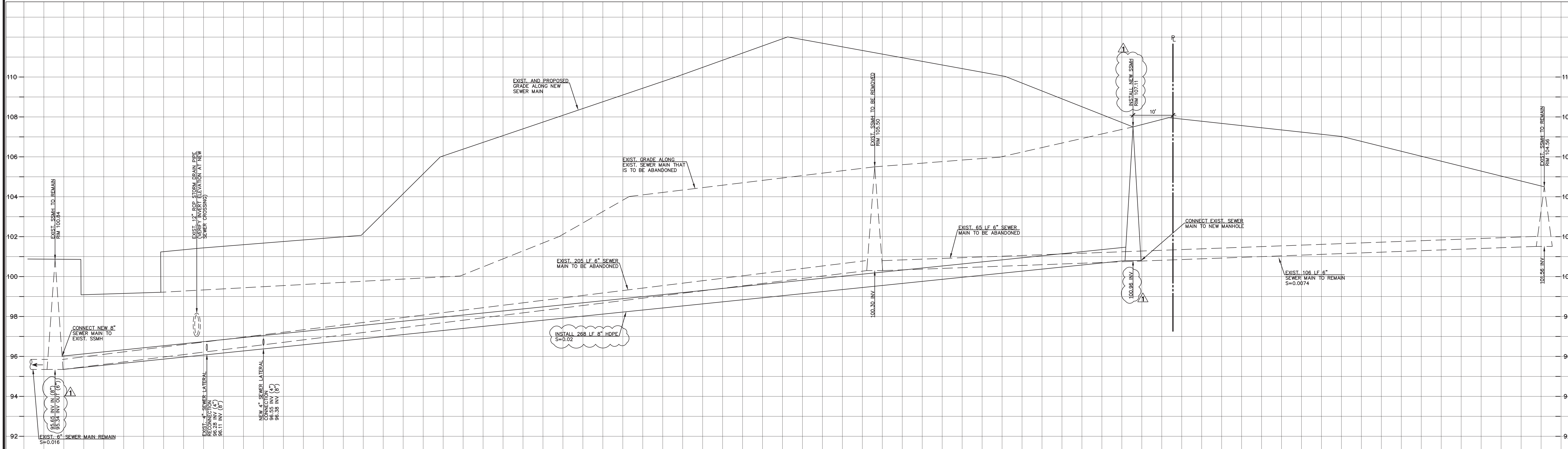

**NEW SEWER MAIN PROFILE**  
 SCALE: 1"=10' HORIZONTAL, 1"=2' VERTICAL

DATE: 09/02/23	BY: DJK
RECORD INFORMATION	DESCRIPTION
NO. 35048	REGISTERED PROFESSIONAL ENGINEER
CIVIL ENGINEERING • LAND SURVEYING	STATE OF CALIFORNIA
965 CENTER STREET • SAN CARLOS • CA 94070 • (650) 593-8580	
PREPARED FOR: PACIFIC PENINSULA GROUP	
SEWER MAIN AND LATERAL RELOCATION PLAN	
358 WALSH ROAD SAN MATEO COUNTY CALIFORNIA	
DRAWN BY: DJK	TOWN OF ATHERTON
DESIGNED BY: VPG	
CHECKED BY: DGM	
SCALE: 1"=10'	
DATE: 09/13/22	
DRAWING NO. 4981-SEWER	
SHEET C-1	
1 OF 2	

THIS PAGE LEFT INTENTIONALLY BLANK





**To: Board of Directors**  
**From: Sergio Ramirez, General Manager**  
**Subject: General Manager's Report**

---

**1) Administrative:**

- a. The San Mateo County LAFCo Public Hearing was held on Wednesday, February 7, 2024, at 2:30 pm. LAFCo upheld their decision to make EPASD a subsidiary district of the City of East Palo Alto.
- b. Bidnet Direct has been implemented and is now live. The first bids to be advertised on the new platform will be the Willow Pump Station Project and the Point Repair Project Phase II. The new bidding platform is linked to the new and old website.
- c. The District has three Board of Directors positions up for election in 2024. The three incumbents must submit paperwork to the county by August of this year.
- d. The District flows at the Menlo Park Pump Station are back to pre-pandemic levels. The flows for 2023 were 3.45 million gallons per daily (MGD) average compared to 3.46 MGD in 2019. This could represent an increase in Silicon Valley Clean Water O&M monthly charges.

**2) Finance:**

- a. The District received a Solid Waste Surplus Distribution in the amount of \$317,824.00 from Recology for year 2022. Reconciliation of such accounts occur one to two years in the arrears. The 2023 surplus or shortfall should be distributed in 2025.
- b. Staff along with HF&H will bring the 2024 Sewer Service Charge rate study to the Board during the February 14, 2024, Regular Board Meeting.

**3) CIP Projects:**

**a. Construction Capital Improvement Program (CIP):**

- i. Ranger Pipelines submitted a revised construction schedule for the Bayfront Improvements Project. The underground pipeline work is scheduled to begin in March.

**b. Levee Improvement Project:**

- i. Anderson Pacific has completed the first phase of the levee project and should begin phase II during the next construction season.
- ii. With phase I of the levee project being complete, staff will begin to ask for reimbursement from the Nation Fish and Wildlife Foundation grant.

**4) Information Technology (IT):**

- a. Staff provided the Board with an update on migrating to the Cloud during the January 24, 2024, Regular Board Meeting.

- 5) **Operations and Maintenance:**
  - a. **Collection System:**
    - i. Designated staff members were out in the field during the recent severe storms. We are happy to report that we did not experience any issues at our creek crossings and other related areas in the system.
  - b. **Pump Facilities:**
    - i. The Pump Facility Supervisor will give an update on the Private STEP/Grider Systems to the Board during the February 28, 2024 Regular Board Meeting.
  - c. **Training:**
    - i. Maintenance staff received Hazardous Waste training on February 5, 2024.
- 6) **Water Quality:**
  - a. **Sharon Heights Golf and Country Club (SHGCC):**
    - i. The 2024 Operation & Maintenance budget for the recycled water facility was submitted and approved. The new annual budget is \$671,950 per year or \$55,996 per month.
  - b. **Bayfront Recycled Water Facility (BRWF):**
    - i. The Recycled Water Committee met with the Project Management team on January 23, 2024, to review the Request for Proposal documents before they are sent to the qualified contractor. The RFP will be out in March of 2024.
  - c. **Woodside Recycled Water Facility (WRWF):**
    - i. The Woodside Recycled Water Facility feasibility study is complete and will be brought to the Board on March 12, 2024. Staff will seek reimbursement from the State Water Board grant that was awarded for the study.
- 7) **Fleet and Facilities:**
  - a. **Vehicle Maintenance:**
    - i. The new Dump Truck is expected to arrive by late June 2024.
- 8) **Personnel:**
  - i. General Manager will be on vacation from March 28 till April 6, 2024. The Water Quality Manager and Operations Superintendent will be in charge in his absence.
- 9) **Upcoming Events:**
  - a. **Next Regular Board Meetings:** Wednesdays, February 14 & 28, 2024.
- 10) **Misc. Items:**
  - a. **West Bay:** The General Manager will update the Board on miscellaneous items related to District operations.
  - b. **Town of Los Altos Hills:** The Town continues to replace the oversize manhole lids with standard lids that are more manageable to lift and maintain.
  - c. **Town of Woodside:** The Pump Crew responded to a power outage at the Town Center Pump Station during recent storm events.



## WEST BAY SANITARY DISTRICT AGENDA ITEM 5

**To:** *Board of Directors*

**From:** *Sergio Ramirez, General Manager*

**Subject:** *Workshop and Discussion regarding the Sewer Service Charge Rate Study for Fiscal Year 2024/25*

---

### Background

West Bay Sanitary District procured the services of HF&H LLC, who has agreed to perform a Sewer Service Charge Rate Study for FY 2024/25. HF&H LLC is in the process of analyzing the proper rate structure to support the District's Operation & Maintenance (O&M) and Capital Replacement needs and to meet O&M and Debt Service obligations for the Silicon Valley Clean Water regional treatment plant.

### Analysis

From discussion on the HF&H analysis to date, the Board will be requested to provide policy direction on the potential sewer service charges for FY 2024/25. Using a rate model, HF&H will demonstrate the effects on revenue of projected rate levels in order to maintain operating and non-operating expenses, CIP projects, and reserve levels overall.

### Fiscal Impact

There is no fiscal impact at this time, however implementation of new sewer service charges and/or connection fees would impact District revenues. A Proposition 218 Notice would follow at a later date.

### Recommendation

The General Manager recommends the Board engage in discussion and provide staff with policy direction regarding the sewer service charges for FY2024-25.

THIS PAGE LEFT INTENTIONALLY BLANK



## WEST BAY SANITARY DISTRICT AGENDA ITEM 6

**To:** *Board of Directors*

**From:** *Robert Scheidt, Assistant Operations Superintendent*

**Subject:** *Authorize the General Manager to Purchase a Mini Excavator*

---

### Background

The District has approximately 1422 mainline segments in easements out of approximately 5,300 line segments. When these segments need repairs from defects such as roots, breaks, collapsed pipe, or sags the inhouse Rehab Crew must hand dig these repairs. The work requires two to three crew members to hand dig and perform the repair over a two-day period. Sometimes the repairs take longer than two days depending on the length and severity.

Over the past several years the crew has rented a mini excavator to make repairs more efficient. When a mini excavator is used most repairs can be completed within the same day.

Staff has rented a mini excavator 12 to 14 times from 2021-2023 for an approximate cost of \$25,822. This includes the equipment cost and does not include the time to pick up and return the rental unit.

### Analysis

The Board approved \$60,000 to purchase a new 2024 Mini Excavator in the FY 2023/24 Budget.

Staff researched an Electric Mini Excavator, however, the \$82,423 price for the unit was not justifiable particularly because it did not include the needed accessories and was not cost effective. The retail price for the basic diesel 2024 Mini Excavator is \$39,643.00 without options or extra attachments (see Bobcat quote.)

The District has used Sourcewell to take advantage of a cooperative bid process and lower pricing on numerous occasions. The District received a quote through Sourcewell for a basic diesel unit in the amount of \$30,949.60 (\$33,783.28 including two trenching buckets) a savings of \$8,693.40 from the retail price for the same unit (see Sourcewell quote.)

Staff solicited two additional bids for similar equipment from Tri-West Tractor, Inc. and Peterson CAT. The Tri-West Tractor quote was \$45,190.00 while the Peterson quote was \$76,316.36.

---

**Report to the District Board for the Regular Meeting of February 14, 2024**

Fiscal Impact

Fiscal impact is \$30,949.60 plus \$25,699.77 for accessories such as Buckets, a Hydraulic Compactor, a Hydraulic Breaker Bar and a Trailer for a total of \$56,649.37, The funds will be used from the Equipment Replacement Fund.

Recommendation

The Assistant Operations Superintendent recommends the Board Authorize the General Manager to Purchase a Mini Excavator and accessories.

Attachments:            Bobcat Retail Quote  
                                 Bobcat Sourcewell Quote  
                                 Tri-West Tractor, Inc. Quote  
                                 Peterson CAT Quote  
                                 Bobcat Accessories Quote



Product Quotation  
 Quotation Number: **NC301704**  
 Quote Sent Date: **Jan 19, 2024**  
 Expiration Date: **Feb 18, 2024**

Your Bobcat Contact  
**Nolan Clark**  
 Phone:  
 E-mail: [nolan.clark@doosan.com](mailto:nolan.clark@doosan.com)

Your Customer Contact

Deliver to  
**WEST BAY SANITARY DISTRICT**  
 500 LAUREL ST  
 MENLO PARK, CA, 94025-3427

Bobcat Dealer  
**Bobcat of Fremont, Fremont, CA**  
 40595 Albrae St.  
 FREMONT, CA, 94538  
 RUSS THIELEN

Bill to  
**NEW GOVERNMENT CUSTOMER**  
**2391333**  
 250 E Beaton Dr  
 West Fargo, ND, 58078-2656

Item Name	Item Number	Quantity	Price Each	Total
<b>E20 T4 Bobcat Compact Excavator</b> <i>Comment: Serial Number: B5VG12303</i>	M5559	1	26,617.50	26,617.50
<b>Standard Equipment:</b>				
15.0 HP			Zero Tail Swing	
Auto-Shift, 2-Speed Travel			Dozer Blade with Blade Extensions	
Auxiliary Hydraulics, Boom Mounted Flush Face Quick Couplers			Horn	
Boom Swing			Hydraulic Joystick Controls	
Long Arm			Rubber Track	
Canopy			Spark Arrestor Muffler	
Includes: Cup Holder, Retractable Seat Belt			Vandalism Protection	
Roll Over Protective Structure (ROPS)- Meets Requirements of ISO 12117-2:2008			Work Light	
Tip Over Protective Structure (TOPS) - Meets Requirements of ISO 12117:2000			Warranty: 2 years, or 2000 hours (whichever occurs first)	
Falling Object Guard Structure (FOGS) - Meets Requirements of ISO 10262				
Control Console Locks				
Control Pattern Selector Valve (ISO/STD)				
<b>Bobcat Canopy Enhanced Controls</b> <i>Included: Includes: Finger-tip Auxiliary Hydraulics, Boom Swing Control, Auto-Shift Travel System</i>	M5559-A02-C04	1	380.10	380.10

Total for E20 T4 Bobcat Compact Excavator	<b>26,997.60</b>
Quote Total - USD	26,997.60
Dealer P.D.I.	200.00
Freight Charges	875.00
Sales Tax	2,877.44
<b>Quote Total - USD</b>	<b>30,949.60</b>

**Comment:**

\*Sales Tax Estimate ONLY. IF Tax Exempt, please include Tax Exempt Certificate with the order.

\*Prices per the Sourcewell Contract #\_040319-CEC.

\*Sourcewell Member Number (if applicable): \_\_\_\_\_

\*All orders should include 1) Accounts Payable Contact and email address, 2) W9 with correct legal entity name, and 3) Bill to Address.

\*Orders may be placed with the contract holder or authorized dealer as allowed by the terms and conditions of the contract. \*A Copy of all orders must be provided to Heather.Messmer@Doosan.com.

\*Contact Holder Information: Clark Equipment Company dba Bobcat Company, Govt Sales, 250 E Beaton Drive, West Fargo, ND 58078. TID# 38-0425350.

\*Payment Terms: Net 60 Days. Credit cards accepted.

\*Remittance address: Clark Equipment Company d/b/a Bobcat Company, P. O. Box 74007382, Chicago, IL 60674-7382

\*Questions can be submitted via email to randy.fuss@doosan.com or by phone at: 1-800-965-4232

<b>Customer Acceptance:</b>	
Quotation Number: NC301704	Purchase Order: _____
<b>Authorized Signature:</b>	
Print: _____	Sign: _____
Date: _____	Email: _____
<b>Addresses:</b>	
Delivery Address: _____	
Billing Address (if different from ship to): _____	
<b>Tax Exempt: Y <input type="checkbox"/> / N <input type="checkbox"/></b>	
Exempt in the State of: _____	
<b>Tax Exempt ID:</b>	
Federal: _____	
State: _____	
Expiration Date: _____	





# E20

## Compact Excavator



Get impressive performance in tight areas with minimal repositioning.

- Ultra-compact design
- 39 to 54 inch retractable track width
- Zero tail swing

**Pay as low as 0% for up to 48 months\* or choose rebates up to \$1,500 USD\*/\$2,000 CAD\* on a Bobcat E20 compact excavator.**

[Contact Dealer](#)

[View Offers](#)

[Find Dealer](#)

[Download Brochure](#)

## E20 Overview

- The Bobcat® E20 compact (mini) excavator delivers impressive performance in tight areas with minimal repositioning.
- Hydraulically retract the undercarriage to only 39 inches to travel through gates or between homes, then expand to 54 inches for a wider footprint and greater performance.
- Zero tail swing gives you better maneuverability on the most restricted jobsites.

## E20 Specs & Compare

[Show more](#)

### REGION SELECTOR

[NORTH AMERICA \(EN\)](#)

SHOPPING TOOLS

BUILD & QUOTE

SEARCH INVENTORY

FIND A DEALER

SPECIAL OFFERS

REQUEST A DEMO

CONTACT A DEALER

BUYING RESOURCES

CONTACT US

CUSTOMER SERVICE

WEBSITE FEEDBACK

DEALER OPPORTUNITIES

GOVERNMENT SALES

FREQUENTLY ASKED QUESTIONS

EMAIL SIGN-UP

ABOUT US

BRAND

INNOVATION

COMMUNITY

PEOPLE

BOBCAT STORIES

AMBASSADORS

LEGAL

PRIVACY POLICY

TERMS & CONDITIONS

RECALLS



*One Tough Animal*

**DOOSAN**

Bobcat Company is a member of the Doosan Group. Doosan is a global leader in construction, grounds maintenance and material handling equipment, power and water solutions, and engineering that has proudly served customers and communities for more than a century.

Bobcat®, the Bobcat logo, the colors of the Bobcat machine and various other product names referenced on this website are trademarks of Bobcat Company in the United States and various other countries.

©2024 Bobcat Company. All rights reserved.



Product Quotation  
 Quotation Number: **RT300738**  
 Quote Sent Date: **Jan 18, 2024**  
 Expiration Date: **Jan 31, 2024**

Prepared By  
**Russ Thielen**  
 Phone: 5106790000  
 Email: russ.thielen@bobcatofthebay.com

Customer  
**WEST BAY SANITARY DISTRICT**  
 500 LAUREL ST  
 MENLO PARK, CA, 94025-3427  
 Phone: +16504776416

Contact

Dealer  
**Bobcat of Fremont, Fremont, CA**  
 40595 Albrae St.  
 FREMONT, CA, 94538

Item Name	Item Number	Quantity	Price Each	Total
<b>E20 T4 Bobcat Compact Excavator</b> <i>Serial Number: BSVG12303</i>	M5559	1	38,025.00	38,025.00
<b>Standard Equipment:</b>				
15.0 HP			Zero Tail Swing	
Auto-Shift, 2-Speed Travel			Dozer Blade with Blade Extensions	
Auxiliary Hydraulics, Boom Mounted Flush Face Quick Couplers			Horn	
Boom Swing			Hydraulic Joystick Controls	
Long Arm			Rubber Track	
Canopy			Spark Arrestor Muffler	
Includes: Cup Holder, Retractable Seat Belt			Vandalism Protection	
Roll Over Protective Structure (ROPS)- Meets Requirements of ISO 12117-2:2008			Work Light	
Tip Over Protective Structure (TOPS) - Meets Requirements of ISO 12117:2000			Warranty: 2 years, or 2000 hours (whichever occurs first)	
Falling Object Guard Structure (FOGS) - Meets Requirements of ISO 10262				
Control Console Locks				
Control Pattern Selector Valve (ISO/STD)				
<b>Bobcat Canopy Enhanced Controls</b>	M5559-A02-C04	1	543.00	543.00
<i>Included:</i> Includes: Finger-tip Auxiliary Hydraulics, Boom Swing Control, Auto-Shift Travel System				
<b>Total for E20 T4 Bobcat Compact Excavator</b>				<b>38,568.00</b>
			Quote Total - USD	38,568.00
			Dealer P.D.I.	200.00
			Freight Charges	875.00
			Sales total before Taxes	39,643.00
			Taxes	0.00
			<b>Quote Total - USD</b>	<b>39,643.00</b>

**Notes:**

Quote valid for this Stock Item Only

**Customer Acceptance:**  
 Quotation Number: RT300738

Purchase Order: \_\_\_\_\_

**Authorized Signature:**

Print: \_\_\_\_\_ Sign: \_\_\_\_\_

Date: \_\_\_\_\_ Email: \_\_\_\_\_ Tax Exempt: Y  / N

# TRI-WEST TRACTOR, INC

6281 SOUTH FRONT ROAD, LIVERMORE, CA 94551-8215  
925/455-8200 \* FAX 925/455-8220

www.tri-westtractor

TO: WEST BAY SANITARY DISTRICT  
500 LAUREL STREET  
MENLO PARK, CA 94025  
ATTN: BOB SCHEIDT

DATE: FEB. 27, 2023

TAKEUCHI TB225  
Compact Excavator  
NEW UNIT

We are pleased to be able to provide you with the following information on the TAKEUCHI TB225. This quotation is valid for 15 days from today's date. (Quotations with specific serial numbers are subject to prior sale.)

Description	TAKEUCHI TB225	
<ul style="list-style-type: none"> <li>• ROPS/TOPS/FOPS 4 Post Canopy</li> <li>• Yanmar 3TNV80F Diesel Engine, 77 Cu. In., 19.6 H.P.</li> <li>• Variable Width Undercarriage – 43" to 59" wide – Hydraulically Retractable</li> <li>• Two Speed Travel with Automatic Shift Down 1.6 / 2.6 mph and Travel Alarm</li> <li>• Cast Iron, wrap-around Counterweight</li> <li>• Pilot operated Joystick Controls with Safety Lock Out</li> <li>• Control Pattern Selector Valve</li> <li>• Adjustable Suspension Seat with Retractable Seat Belt</li> <li>• Proportional Slide Switch Control Auxiliary Hydraulics with Detent Function</li> <li>• Variable Displacement Axial Piston Main Hydraulic Pumps</li> <li>• Two-way Auxiliary Hydraulic Circuit routed to end of the Arm with Aux. Flow of 9.96 GPM</li> <li>• Thumb Mount Bracket installed</li> <li>• Electrohydraulic push button controls of Auxiliary Hydraulic Circuit</li> <li>• Boom Swing: Left 80 degrees / Right 60 degrees</li> <li>• Heavy Duty Knock Down Blade</li> <li>• 9.8" Rubber Tracks</li> </ul>		
<b>Brief Description:</b>	Operating Weight: 4,993 lbs. Crawler Width – 43" to 59" Maximum Digging Depth: 8' 5"	Horsepower / RPM: 19.6 / 2,400 Bucket Digging Force: 4,339 lbs. Auxiliary Flow: 9.96 GPM

**List Price: \$ 50,814.00**

**Quotation Price: \$ 45,190.00**

**TAKEUCHI FINANCING AT 0% FOR 24 MONTHS UP TO 3.99% FOR 60 MONTHS**

**TAKEUCHI 2 YEAR – 2,000 HOUR STANDARD WARRANTY**

Options:		
• ROPS CANOPY		\$ INCLUDED
• KNOCK DOWN DOZER		\$ INCLUDED
• AUX. HYDRAULICS TO TIP OF STICK		\$ INCLUDED
• TAG MFG. QUICK COUPLER – MANUAL		\$ INCLUDED
• TAG MFG. 18" DIGGING BUCKET – COUPLER STYLE		\$ INCLUDED
• TAG MFG. 24" DIGGING BUCKET – COUPLER STYLE		\$ INCLUDED
• OPTIONS		
• TAG MFG. 36" DITCH CLEAN UP BUCKET – COUPLER STYLE		\$ 1,520.00
• TAG MFG. HYDRAULIC THUMB – INSTALLED		\$ 2,455.00

Prices are quoted without sales tax and are F.O. B. Livermore. Thank you for the opportunity to quote this machine. BILL ADKINS

Jon H Hamilton



Feb 23, 2023

**West Bay Sanitary District**  
500 Laurel St  
Menlo Park  
California  
94025

Attention: Robert Scheidt

**RE: Quote 212366-01**

Dear Sir,

We would like to thank you for your interest in our company and our products, and are pleased to quote the following for your consideration.

One (1) New Caterpillar Model: 303.5 Compact Construction Equipment

**STOCK NUMBER:** PT00545      **SERIAL NUMBER:** 0RE902184      **YEAR:** 2023      **SMU:** 4

**MACHINE SPECIFICATIONS**

303.5 07A CR MHE CFG1B	616-3216
303.5 07A CR HYD	558-1751
SEAT, SUSPENSION, VINYL	519-9266
TRAVEL LEVERS AND PEDALS	519-9283
CAT KEY, WITH PASS CODE OPTION	525-4465
FILM, PRODUCT LINK, ANSI	541-4787
2 WAY CONTROL	542-1495
FILM, INC. CANADA	542-1504
BOOM LIGHT, LED	542-8886
HYDRAULIC OIL, STD	546-1520
CWT, STANDARD	555-1839
SOFTWARE, PROPORTIONAL CONTROL	557-1709
SOFTWARE, STICK STEER CONTROL	557-1710
SOFTWARE, CODED START	557-1713
ALARM, TRAVEL	558-1744
BOOM, STANDARD	558-1754
CONTROL, 1ST AUX, JOYSTICK	558-1757
LINES, BOOM W/O BLCV	558-1760
LINES, STICK W/O	558-1763
UNDERCARRIAGE, FIXED, STD BLD	558-1766
CANOPY, ROPS	563-6658
TRACK, 12", RUBBER	566-2914



INSTRUCTIONS, ANSI	569-3572
LINKAGE, BUCKET,	571-9088
STICK, LONG, W/ THUMB BRACKET	571-9661
DRAIN, ECOLOGY	573-4364
PRODUCT LINK, CELLULAR PL243	573-9677
LINES, BUCKET, LONG STICK	575-2776
BLADE, FIXED, BOCE	575-4418
LINES, 1ST AUX, LONG STICK	575-7225
ENGINE, EPA TIER	576-2961
MONITOR NEXT GEN, NO CAMERA	580-7179
ACCUMULATOR	588-2227
FILM, CANOPY	594-5727
FLOORMAT, CANOPY, W/TRAVEL	594-7895
SEAT BELT, 3" RETRACTABLE	599-7202
FILM, ROPS, ISO,	602-3576
SERIALIZED TECHNICAL MEDIA KIT	421-8926
LANE 2 ORDER	0P-9002
PACKING, LAST MILE PROGRAM	0P-4299
SHIPPING/STORAGE PROTECTION	0P-2266
PINS, BUCKET, 40MM	154-2638
BUCKET-HD, 18", 2.9 FT3, 3T	464-9902
BUCKET-HD, 24", 4.2 FT3, 3T	464-9904

SELL PRICE	\$69,774.96
EXT WARRANTY	Included
<b>NET BALANCE DUE</b>	<b>\$69,774.96</b>
SALES TAX (9.375%)	\$6,541.40
<b>AFTER TAX BALANCE</b>	<b>\$76,316.36</b>

**WARRANTY**

Standard Warranty:	24 Months, 2000 Hours Standard Warranty
Extended Warranty:	303.5-36 MO/3000 HR POWERTRAIN + HYDRAULICS + TECH (Tier 4)

**F.O.B/TERMS: Menlo Park**

Accepted by \_\_\_\_\_ on \_\_\_\_\_

\_\_\_\_\_  
Signature

This Quote is valid for 30 days, after which time we reserve the right to re-quote. If there are any questions, please do not hesitate to contact me.

Sincerely,

Jon Hamilton  
Governmental Sales Representative  
Peterson CAT  
(925) 580-2439  
JHHamilton@petersoncat.com



# Cat<sup>®</sup> 303.5 CR

## MINI EXCAVATOR

### FEATURES:

The Cat<sup>®</sup> 303.5 CR Mini Excavator delivers power and performance in a compact size to help you work in a wide range of applications.

### ALL DAY COMFORT

- Choose either a canopy or a sealed and pressurized cab which can be equipped with air conditioning, adjustable wrist rests, and a suspension seat option to help keep you working comfortably all day long.

### EASY TO OPERATE

- Controls are easy to use and the intuitive Next Generation LCD monitor provides easy to read machine information. An advanced touchscreen monitor can also be equipped.

### STICK STEER TRAVEL MODE

- Moving around the job site is even easier with the Cat Stick Steer option. Easily switch from traditional travel controls with levers and pedals to joystick controls to move the machine and to operate the blade. The benefit of less effort and improved control is in your hands!

### BIG PERFORMANCE IN A COMPACT DESIGN

- Strong lift and dig performance helps you get the job done faster. The compact radius design lets you access and work in the tightest areas. Dozer float allows for easy clean up.

### SAFETY ON THE JOB SITE

- Your safety is our top priority. The Cat mini excavator is designed to help keep you safe on the job. Courtesy work lights and a fluorescent retractable seat belt are just a couple of the safety features we've built into the machine.

### SIMPLE SERVICE FOR LESS DOWNTIME

- Maintenance is quick and easy on the Cat mini excavator. Routine check points are easy to access at ground level through the side doors. The unique tilt up cab or canopy lets you reach additional service areas when needed.

### LOWER OPERATING COSTS

- Equipped with features such as auto idle, auto engine shutdown, and efficient hydraulics with a variable displacement pump, the Cat mini excavator was designed with reducing your operating costs in mind.

### UNMATCHED DEALER SUPPORT

- Your Cat dealer is here to help you reach your business goals. From providing equipment solutions to operator training to service needs and beyond, your Cat dealer is ready to help.

## Specifications

### Engine

Engine Model	C1.7	
<b>Net Power @ 2,200 rpm</b>		
ISO 9249, 80/1269/EEC	17.6 kW	23.6 hp
<b>Gross Power @ 2,200 rpm</b>		
SAE J1995:2014	18.4 kW	24.7 hp
Bore	84.0 mm	3.3 in
Stroke	100.0 mm	3.9 in
Displacement	1.7 L	104.0 in <sup>3</sup>

- Meets U.S. EPA Tier 4 Final and EU Stage V emission standards.
- Net power advertised is the power available at the flywheel when the engine is at rated speed and rated power when the engine is installed with the factory configured fan, air intake system, exhaust system, and alternator with a minimum alternator load.

### Weights

Minimum Operating Weight with Canopy*	3480 kg	7,673 lb
Maximum Operating Weight with Canopy**	4050 kg	8,930 lb
Minimum Operating Weight with Cab*	3620 kg	7,982 lb
Maximum Operating Weight with Cab**	4190 kg	9,239 lb
EU: CE Plate Weight with Canopy***	3530 kg	7,784 lb
EU: CE Plate Weight with Cab***	3630 kg	8,004 lb

\*Minimum Weight is based on fixed rubber tracks, operator, full fuel tank, standard stick, blade, bucket and no extra counterweight.

\*\*Maximum Weight is based on steel tracks, operator, full fuel tank, long stick, blade, bucket and extra counterweight.

\*\*\*CE Plate Weight is based on the most common EU configuration. Includes 75 kg (165 lb) operator and full fuel tank and excludes bucket.

# 303.5 CR Mini Excavator

## Weight Increase from Minimum Configuration

Cab	140 kg	309 lb
Counterweight (light)	100 kg	221 lb
Counterweight (extra)	250 kg	551 lb
Long Stick	20 kg	44 lb
Steel Tracks	130 kg	287 lb
Angle Blade	160 kg	353 lb

## Travel System

Travel Speed – High	4.5 km/h	2.8 mph
Travel Speed – Low	2.6 km/h	1.6 mph
Maximum Traction Force – High Speed	16.9 kN	3,799 lbf
Maximum Traction Force – Low Speed	31.0 kN	6,969 lbf
Ground Pressure – Minimum Weight	29.6 kPa	4.3 psi
Ground Pressure – Maximum Weight	35.7 kPa	5.2 psi
Gradeability (maximum)	30 degrees	

## Service Refill Capacities

Cooling System	7.0 L	1.8 gal
Engine Oil	6.0 L	1.6 gal
Fuel Tank	45.0 L	11.9 gal
Hydraulic Tank	20.0 L	5.3 gal
Hydraulic System	45.0 L	11.9 gal

## Hydraulic System

Load Sensing Hydraulics with Variable Displacement Piston Pump

Pump Flow @ 2,400 rpm	100 L/min	26 gal/min
Operating Pressure – Equipment	245 bar	3,553 psi
Operating Pressure – Travel	245 bar	3,553 psi
Operating Pressure – Swing	181 bar	2,625 psi
Auxiliary Circuit – Primary		
Flow*	70 L/min	18 gal/min
Pressure*	245 bar	3,553 psi
Auxiliary Circuit – Secondary		
Flow*	25 L/min	7.0 gal/min
Pressure*	245 bar	3,553 psi
Digging Force – Stick (standard)	18.9 kN	4,249 lbf
Digging Force – Stick (long)	16.9 kN	3,799 lbf
Digging Force – Bucket	33.0 kN	7,419 lbf

\*Flow and pressure are not combinable. Under load, as flow rises pressure goes down.

## Swing System

Machine Swing Speed	9.0 rpm
Boom Swing – Left	75 Degrees
Boom Swing – Right	50 Degrees

## Blade

Width	1780 mm	70.1 in
Height	350 mm	13.8 in

## Certification – Cab and Canopy

Roll Over Protective Structure (ROPS)	ISO 12117-2:2008
Tip Over Protective Structure (TOPS)	ISO 12117:1997
Top Guard	ISO 10262:1998 (Level I)

## Sound

Operator Sound Pressure (ISO 6396:2008)	78 dB(A)
Average Exterior Sound Pressure (ISO 6395:2008)	94 dB(A)

• European Union Directive "2000/14/EC"

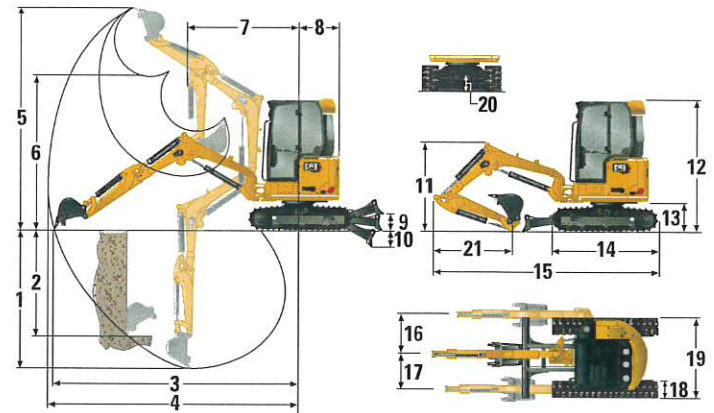

## Dimensions

	Standard Stick	Long Stick
1 Dig Depth	2810 mm (110.6 in)	3110 mm (122.4 in)
2 Vertical Wall	2250 mm (88.6 in)	2390 mm (94.1 in)
3 Maximum Reach at Ground Level	5130 mm (202.0 in)	5380 mm (211.8 in)
4 Maximum Reach	5270 mm (207.5 in)	5510 mm (216.9 in)
5 Maximum Dig Height	4920 mm (193.7 in)	5020 mm (197.6 in)
6 Maximum Dump Clearance	3490 mm (137.4 in)	3600 mm (141.7 in)
7 Boom in Reach	1760 mm (69.3 in)	1860 mm (73.2 in)
8 Tail Swing		
without Counterweight	890 mm (35.0 in)	890 mm (35.0 in)
with Counterweight (light)	960 mm (37.8 in)	960 mm (37.8 in)
with Counterweight (extra)	1005 mm (39.6 in)	1005 mm (39.6 in)
9 Maximum Blade Height	385 mm (15.2 in)	385 mm (15.2 in)
10 Maximum Blade Depth	535 mm (21.1 in)	535 mm (21.1 in)
11 Boom Height in Shipping Position	1520 mm (59.8 in)	1750 mm (68.9 in)
12 Overall Shipping Height	2480 mm (97.6 in)	2480 mm (97.6 in)
13 Swing Bearing Height	565 mm (22.2 in)	565 mm (22.2 in)
14 Overall Undercarriage Length	2220 mm (87.4 in)	2220 mm (87.4 in)
15 Overall Shipping Length†	4800 mm (189.0 in)	4850 mm (190.9 in)
16 Boom Swing Right	870 mm (34.3 in)	870 mm (34.3 in)
17 Boom Swing Left	640 mm (25.2 in)	640 mm (25.2 in)
18 Track Belt/Shoe Width	300 mm (11.8 in)	300 mm (11.8 in)
19 Track Width	1780 mm (70.1 in)	1780 mm (70.1 in)
20 Ground Clearance	310 mm (12.2 in)	310 mm (12.2 in)
21 Stick Length	1260 mm (49.6 in)	1560 mm (61.4 in)

†Overall Shipping Length depends on blade position during shipment.

## Cab

Lift Capacities – Minimum Configuration			Lift Point Radius – 2 m (6.6 ft)			Lift Point Radius – 3 m (9.8 ft)			Lift Point Radius (Maximum)			
			Over Front			Over Front			Over Front			m (ft)
			Blade Down	Blade Up	Over Side	Blade Down	Blade Up	Over Side	Blade Down	Blade Up	Over Side	
3 m (9.8 ft)	Standard Stick	kg (lb)				*917 (*2,022)	*917 (*2,022)	904 (1,993)	*835 (*1,841)	583 (1,285)	575 (1,268)	3.95 (13.0)
	Long Stick	kg (lb)							*758 (*1,671)	514 (1,133)	507 (1,118)	4.26 (14.0)
2 m (6.6 ft)	Standard Stick	kg (lb)				*1176 (*2,593)	888 (1,958)	867 (1,911)	*809 (*1,784)	483 (1,065)	478 (1,054)	4.41 (14.5)
	Long Stick	kg (lb)				*1033 (*2,377)	892 (1,967)	870 (1,918)	*750 (*1,653)	435 (959)	430 (948)	4.67 (15.3)
1 m (3.3 ft)	Standard Stick	kg (lb)				*1547 (*3,411)	833 (1,836)	813 (1,792)	*860 (*1,896)	454 (1,001)	449 (990)	4.54 (14.9)
	Long Stick	kg (lb)				*1462 (*3,223)	831 (1,832)	811 (1,788)	*805 (*1,775)	410 (904)	406 (895)	4.79 (15.7)
0 m (0 ft)	Standard Stick	kg (lb)				*1676 (*3,695)	805 (1,775)	786 (1,733)	*947 (*2,088)	472 (1,041)	466 (1,027)	4.39 (14.4)
	Long Stick	kg (lb)	*1345 (*2,965)	*1345 (*2,965)	*1345 (*2,965)	*1696 (*3,739)	793 (1,748)	774 (1,706)	*907 (*2,000)	424 (935)	420 (926)	4.63 (15.2)

Minimum Weight includes cab, rubber tracks, no extra counterweight, operator, full fuel tank and blade.

Lift Capacities – Maximum Configuration			Lift Point Radius – 2 m (6.6 ft)			Lift Point Radius – 3 m (9.8 ft)			Lift Point Radius (Maximum)			
			Over Front			Over Front			Over Front			m (ft)
			Blade Down	Blade Up	Over Side	Blade Down	Blade Up	Over Side	Blade Down	Blade Up	Over Side	
3 m (9.8 ft)	Standard Stick	kg (lb)				*917 (*2,022)	*917 (*2,022)	*917 (*2,022)	*835 (*1,841)	720 (1,587)	663 (1,462)	3.95 (13.0)
	Long Stick	kg (lb)							*758 (*1,671)	638 (1,407)	588 (1,296)	4.26 (14.0)
2 m (6.6 ft)	Standard Stick	kg (lb)				*1176 (*2,593)	1086 (2,394)	988 (2,178)	*809 (*1,784)	602 (1,327)	556 (1,226)	4.41 (14.5)
	Long Stick	kg (lb)				*1033 (*2,377)	*1033 (*2,377)	992 (2,187)	*750 (*1,653)	546 (1,204)	504 (1,111)	4.67 (15.3)
1 m (3.3 ft)	Standard Stick	kg (lb)				*1547 (*3,411)	1031 (2,273)	936 (2,064)	*860 (*1,896)	568 (1,252)	524 (1,155)	4.54 (14.9)
	Long Stick	kg (lb)				*1462 (*3,223)	1029 (2,269)	933 (2,057)	*805 (*1,775)	518 (1,142)	477 (1,052)	4.79 (15.7)
0 m (0 ft)	Standard Stick	kg (lb)				*1676 (*3,695)	1003 (2,211)	909 (2,004)	*947 (*2,088)	591 (1,303)	545 (1,202)	4.39 (14.4)
	Long Stick	kg (lb)	*1345 (*2,965)	*1345 (*2,965)	*1345 (*2,965)	*1696 (*3,739)	991 (2,185)	897 (1,978)	*907 (*2,000)	536 (1,182)	494 (1,089)	4.63 (15.2)

Maximum Weight includes cab, steel tracks, extra counterweight, operator, full fuel tank and blade.

## Canopy

Lift Capacities – Minimum Configuration			Lift Point Radius – 2 m (6.6 ft)			Lift Point Radius – 3 m (9.8 ft)			Lift Point Radius (Maximum)			
			Over Front			Over Front			Over Front			m (ft)
			Blade Down	Blade Up	Over Side	Blade Down	Blade Up	Over Side	Blade Down	Blade Up	Over Side	
3 m (9.8 ft)	Standard Stick	kg (lb)				*917 (*2,022)	884 (1,949)	866 (1,909)	*835 (*1,841)	555 (1,224)	549 (1,210)	3.95 (13.0)
	Long Stick	kg (lb)							*764 (*1,684)	490 (1,080)	485 (1,069)	4.26 (14.0)
2 m (6.6 ft)	Standard Stick	kg (lb)				*1176 (*2,593)	846 (1,865)	829 (1,828)	*809 (*1,784)	458 (1,010)	455 (1,003)	4.41 (14.5)
	Long Stick	kg (lb)				*1034 (*2,280)	851 (1,876)	834 (1,839)	*755 (*1,664)	413 (911)	411 (906)	4.67 (15.3)
1 m (3.3 ft)	Standard Stick	kg (lb)				*1547 (*3,411)	791 (1,744)	776 (1,711)	*860 (*1,896)	429 (946)	427 (941)	4.54 (14.9)
	Long Stick	kg (lb)				*1461 (*3,221)	788 (1,737)	772 (1,702)	*809 (*1,784)	389 (858)	387 (853)	4.79 (15.7)
0 m (0 ft)	Standard Stick	kg (lb)				*1676 (*3,695)	763 (1,682)	749 (1,651)	*947 (*2,088)	446 (983)	443 (977)	4.39 (14.4)
	Long Stick	kg (lb)	*1351 (*2,978)	*1351 (*2,978)	*1351 (*2,978)	*1694 (*3,735)	749 (1,651)	735 (1,620)	*908 (*2,002)	402 (886)	399 (880)	4.63 (15.2)

Minimum Weight includes canopy, rubber tracks, no extra counterweight, operator, full fuel tank and blade.

Lift Capacities – Maximum Configuration			Lift Point Radius – 2 m (6.6 ft)			Lift Point Radius – 3 m (9.8 ft)			Lift Point Radius (Maximum)			
			Over Front			Over Front			Over Front			m (ft)
			Blade Down	Blade Up	Over Side	Blade Down	Blade Up	Over Side	Blade Down	Blade Up	Over Side	
3 m (9.8 ft)	Standard Stick	kg (lb)				*917 (*2,022)	*917 (*2,022)	*917 (*2,022)	*835 (*1,841)	691 (1,523)	639 (1,409)	3.95 (13.0)
	Long Stick	kg (lb)							*758 (*1,671)	612 (1,349)	566 (1,248)	4.26 (14.0)
2 m (6.6 ft)	Standard Stick	kg (lb)				*1176 (*2,593)	1044 (2,302)	953 (2,101)	*809 (*1,784)	577 (1,272)	534 (1,177)	4.41 (14.5)
	Long Stick	kg (lb)				*1033 (*2,277)	*1033 (*2,277)	956 (2,108)	*750 (*1,653)	523 (1,153)	483 (1,065)	4.67 (15.3)
1 m (3.3 ft)	Standard Stick	kg (lb)				*1547 (*3,411)	989 (2,180)	901 (1,986)	*860 (*1,896)	544 (1,199)	504 (1,111)	4.54 (14.9)
	Long Stick	kg (lb)				*1462 (*3,223)	987 (2,176)	898 (1,980)	*805 (*1,775)	495 (1,091)	458 (1,010)	4.79 (15.7)
0 m (0 ft)	Standard Stick	kg (lb)				*1676 (*3,695)	961 (2,199)	874 (1,927)	*947 (*2,088)	566 (1,248)	523 (1,153)	4.39 (14.4)
	Long Stick	kg (lb)	*1345 (*2,965)	*1345 (*2,965)	*1345 (*2,965)	*1696 (*3,739)	949 (2,092)	862 (1,900)	*907 (*2,000)	513 (1,131)	473 (1,043)	4.63 (15.2)

Maximum Weight includes canopy, steel tracks, extra counterweight, operator, full fuel tank and blade.

\*The above loads are in compliance with hydraulic excavator lift capacity rating standard ISO 10567:2007 and they do not exceed 87% of hydraulic lifting capacity or 75% of tipping capacity. The excavator bucket weight is not included on this chart. Lifting capacities are for standard stick.

# 303.5 CR Mini Excavator

## Standard and Optional Equipment

Standard and optional equipment may vary. Consult your Cat dealer for details.

	Standard	Optional		Standard	Optional
<b>ENGINE</b>			<b>OPERATOR ENVIRONMENT (continued)</b>		
Cat® C1.7 NA Engine (U.S. EPA Tier 4 Final/EU Stage V)	✓		Next Generation Color LCD Monitor (IP66)	✓	
Automatic Engine Idle	✓		– Fuel Level and Coolant Temperature Gauges	✓	
Automatic Engine Shutdown	✓		– Maintenance and Machine Monitoring	✓	
Automatic Two Speed Travel	✓		– Performance and Machine Adjustments	✓	
Fuel Water Separator	✓		– Numeric Security Code	✓	
Power on Demand (not available in all regions)	✓		– Multiple Languages	✓	
Variable Displacement Piston Pump	✓		– Hour Meter with Wake Up Switch	✓	
Load Sensing/Flow Sharing Hydraulics	✓		– Jog Dial (cab only)	✓	
<b>HYDRAULICS</b>			Next Generation Advanced Monitor		✓
Smart Tech Electronic Pump	✓		– Touch Screen		✓
Accumulator	✓		– Site Reference System		✓
Automatic Swing Brake	✓		– High Definition Camera Capable (IP68 and IP69K)		✓
Auxiliary Hydraulic Lines	✓		– Numeric Security Code		✓
One and Two Way Auxiliary Flow	✓		<b>UNDERCARRIAGE</b>		
Continuous Auxiliary Flow	✓		Rubber Belt (300 mm/11.8 in wide)	✓	
Auxiliary Line Quick Disconnects	✓		Steel Track (300 mm/11.8 in wide)		✓
<b>OPERATOR ENVIRONMENT</b>			Dozer Blade	✓	
Tilt-up Canopy or Tilt-Up Cab	✓		Dozer Blade Float	✓	
Cab with Air Conditioning		✓	Angle Blade		✓
Cab with Heater		✓	Tie Downs on Track Frame	✓	
Top Guard ISO 10262:1998 Level I	✓		<b>BOOM, STICK AND LINKAGES</b>		
ROPS – ISO 12117-2:2008	✓		One Piece Boom (2400 mm/94.5 in)	✓	
TOPS – ISO 12117:1997	✓		Standard Stick (1260 mm/49.6 in)	✓	
Stick Steer Mode	✓		Long Stick (1560 mm/61.4 in)		✓
Travel Cruise Control	✓		Front Shovel Capable	✓	
Control Pattern Changer (optional in some regions)	✓		Pin-On	✓	
Adjustable Wrist Rests	✓		Dual Lock Manual Coupler		✓
Washable Floor Mat	✓		Hydraulic Coupler		✓
Travel Pedals and Hand Levers	✓		Thumb Ready (not available in all regions)	✓	
No Travel Pedals and Hand Levers (optional in some regions)		✓	Certified Lifting Eye (optional in some regions)	✓	
Machine Security	✓		Attachments including Couplers, Thumbs, Buckets, Augers and Hammers		✓
Standard Key with Pass Code	✓		2nd Auxiliary Hydraulic Lines		✓
Push to Start with Key Fob/Pass Code		✓	Bucket Divert Lines		✓
Fabric Suspension Seat (Cab only)	✓		Boom Lowering Check Valve		✓
Vinyl Suspension Seat (Canopy only)	✓		Stick Lowering Check Valve		✓
Vinyl Non-Suspension Seat (Canopy only) (not available in all regions)		✓	Hydraulic Quick Coupler Lines (not available in all regions)		✓
Hydraulic Lockout – All Controls	✓		<b>ELECTRICAL</b>		
Retractable High Visibility Seat Belt (75 mm/3 in)	✓		12 Volt Battery	✓	
Coat Hook	✓		Software (machine and monitor)	✓	
Cup Holder	✓		Maintenance Free Battery	✓	
Storage Pocket	✓		Battery Disconnect	✓	
Skylight	✓		Signaling/Warning Horn	✓	
Mounting Bosses for Front	✓		12 Volt Power Socket	✓	
Signaling/Warning Horn	✓		Product Link PL243 (regulations apply)		✓
Interior Light (Cab only)	✓		Product Link PLE643 (regulations apply)		✓
Boom Light, Halogen (not available in all regions)	✓		Travel Alarm (standard in some regions)	✓	
LED Front Lights		✓	<b>GUARDING</b>		
LED Front and Rear Lights		✓	Polycarbonate Half Height Front Guard (Canopy only)		✓
LED Boom Light		✓	Polycarbonate Front Guard (ISO 10262:1998 Level I and EN356 P5A)		✓
Utility Space for Mobile Phone	✓		Heavy Duty Front Guard ISO 10262:1998 Level II		✓
Mirrors Left and Right		✓	<b>OTHER</b>		
Camera		✓	Bio Oil Capable		✓
Radio – Bluetooth®, Auxiliary, Microphone, USB (charging only) (Cab only)		✓	Eco Drain		✓
			Water Jacket Heater		✓
			Light Counterweight (100 kg/221 lb)		✓
			Extra Counterweight (250 kg/551 lb)		✓

For more complete information on Cat products, dealer services, and industry solutions, visit us on the web at [www.cat.com](http://www.cat.com)

© 2021 Caterpillar  
All rights reserved

Materials and specifications are subject to change without notice. Featured machines in photos may include additional equipment. See your Cat dealer for available options.

CAT, CATERPILLAR, LET'S DO THE WORK, their respective logos, "Caterpillar Corporate Yellow," the "Power Edge" and Cat "Modern Hex" trade dress as well as corporate and product identity used herein, are trademarks of Caterpillar and may not be used without permission.

AEHQ8351-00 (03-2021)  
Build Number: 07A  
(Global excluding  
China and Japan)



648



Product Quotation  
 Quotation Number: JP305747  
 Quote Sent Date: Jan 23, 2024  
 Expiration Date: Jan 31, 2024

Prepared By  
**John Perkins**  
 Phone: 510-298-7161  
 Email: John.Perkins@BobcatOfthebay.com

Customer  
**WEST BAY SANITARY DISTRICT**  
 500 LAUREL ST  
 MENLO PARK, CA, 94025-3427  
 Phone: +16504776416

Contact

Dealer  
**Bobcat of Fremont, Fremont, CA**

Item Name	Item Number	Quantity	Price Each	Total
<b>HB680 Hydraulic Breaker with Nail Point</b>	7113419	1	6,519.00	6,519.00
Pin-On Mounting Cap - HB680/NB140	7117752	1	515.00	515.00
Hose Kit - HB680, HB880	6727411	1	301.00	301.00
<b>Total for HB680 Hydraulic Breaker with Nail Point</b>				<b>7,335.00</b>
Quote Total - USD				7,335.00
Sales total before Taxes				7,335.00
Taxes				724.33
<b>Quote Total - USD</b>				<b>8,059.33</b>

**Customer Acceptance:**  
 Quotation Number: JP305747      Purchase Order: \_\_\_\_\_

**Authorized Signature:**  
 Print: \_\_\_\_\_ Sign: \_\_\_\_\_

Date: \_\_\_\_\_ Email: \_\_\_\_\_ Tax Exempt: Y  / N

# Hydraulic Breaker Attachment



- Turn your compact loader or excavator into a powerfully precise demolition machine
- Provides powerful force to break through concrete, rock, and asphalt effortlessly
- Delivers maximum efficiency by matching hydraulic capacity of the carrier to the breaker, allowing consistent machine-to-breaker performance
- Provides a quieter and smoother operation while still maintaining blows per minute

[Contact Local Dealer](#)



[Request a Demo](#)

[Find a Dealer](#)

[Search for Parts](#)

## Features & Benefits

---

[Expand all](#) ▾

Auto Power ▾

Breaker Cradle ▾

Carrier Versatility ▾

Easy, Minimal Maintenance ▾

Easy Mounting ▾

Energy Chamber with Diaphragm ▾

Quite Operation ▾

Hose Guard ▾

Steel Ring System ▾

Go/No-Go Gauge ▾

Single Lower Bushing ▾

## Top Tasks

---

- Precise demolition jobs
- Interior demolition
- Flatwork demolition
- Road repair

## Required Components

---

The following components are required to operate this attachment and must be purchased separately:

- Breaker bits

# Compatible Models

▼ Compact Excavators 15

▼ Compact Excavators, Non-Current Models 1

▼ Compact Track Loaders 11

▼ Mini Track Loaders 1

▼ Skid-Steer Loaders 13

▼ Small Articulated Loaders 2

## REGION SELECTOR

🌐 NORTH AMERICA (EN)

EMAIL SIGN-UP

SHOPPING TOOLS

ABOUT US

BUILD & QUOTE

BRAND

SEARCH INVENTORY

INNOVATION

FIND A DEALER

COMMUNITY

SPECIAL OFFERS

PEOPLE

REQUEST A DEMO

BOBCAT STORIES

CONTACT A DEALER

AMBASSADORS

BUYING RESOURCES

CONTACT US

LEGAL

CUSTOMER SERVICE

PRIVACY POLICY

WEBSITE FEEDBACK

TERMS & CONDITIONS

DEALER OPPORTUNITIES

RECALLS

GOVERNMENT SALES

FREQUENTLY ASKED QUESTIONS



*One Tough Animal*

**DOOSAN**

Bobcat®, the Bobcat logo, the colors of the Bobcat machine and various other product names referenced on this website are trademarks of Bobcat Company in the United States and various other countries.

©2024 Bobcat Company. All rights reserved.



Product Quotation  
 Quotation Number: **JP306711**  
 Quote Sent Date: **Jan 23, 2024**  
 Expiration Date: **Jan 31, 2024**

Prepared By  
**John Perkins**  
 Phone: 510-298-7161  
 Email: John.Perkins@BobcatOffthebay.com

Customer  
**WEST BAY SANITARY DISTRICT**  
 500 LAUREL ST  
 MENLO PARK, CA, 94025-3427  
 Phone: +16504776416

Contact

Dealer  
**Bobcat of Fremont, Fremont, CA**

Item Name	Item Number	Quantity	Price Each	Total
<b>Packer Wheel</b>	DC-12SKH	1	4,385.00	4,385.00
<b>Total for Packer Wheel</b>				<b>4,385.00</b>
Quote Total - USD				4,385.00
Sales total before Taxes				4,385.00
Taxes				433.02
<b>Quote Total - USD</b>				<b>4,818.02</b>

**Notes:** PINS INCLUDED / 11" WIDTH, 350 LBS / 7 - 10 DAYS TO SHIP  
 \*\*CUSTOM ORDER ITEM FROM ACE WHEELS\*\*

<b>Customer Acceptance:</b>	
Quotation Number: <b>JP306711</b>	Purchase Order: _____
<b>Authorized Signature:</b>	
Print: _____	Sign: _____
Date: _____	Email: _____ Tax Exempt: Y <input type="checkbox"/> / N <input type="checkbox"/>



Product Quotation  
 Quotation Number: **JP305749**  
 Quote Sent Date: **Jan 23, 2024**  
 Expiration Date: **Jan 31, 2024**

Prepared By  
**John Perkins**  
 Phone: 510-298-7161  
 Email: John.Perkins@BobcatOfthebay.com

Customer  
**WEST BAY SANITARY DISTRICT**  
 500 LAUREL ST  
 MENLO PARK, CA, 94025-3427  
 Phone: +16504776416

Contact

Dealer  
**Bobcat of Fremont, Fremont, CA**

Item Name	Item Number	Quantity	Price Each	Total
12" Trenching Bucket, Pin-On, 3 Bolt-On Teeth	6715496	1	757.00	757.00
Total for 12" Trenching Bucket, Pin-On, 3 Bolt-On Teeth				<b>757.00</b>
16" Trenching Bucket, Pin-On, 3 Bolt-On Teeth	6715497	1	825.00	825.00
Total for 16" Trenching Bucket, Pin-On, 3 Bolt-On Teeth				<b>825.00</b>
39" Grading Bucket, No Teeth	6715499	1	997.00	997.00
Total for 39" Grading Bucket, No Teeth				<b>997.00</b>
Quote Total - USD				2,579.00
Sales total before Taxes				2,579.00
Taxes				254.68
<b>Quote Total - USD</b>				<b>2,833.68</b>

**Notes:**

<b>Customer Acceptance:</b>	
Quotation Number: JP305749	Purchase Order: _____
<b>Authorized Signature:</b>	
Print: _____	Sign: _____
Date: _____	Email: _____ Tax Exempt: Y <input type="checkbox"/> / N <input type="checkbox"/>



Product Quotation  
 Quotation Number: **JP305753**  
 Quote Sent Date: **Jan 23, 2024**  
 Expiration Date: **Jan 31, 2024**

Prepared By  
**John Perkins**  
 Phone: 510-298-7161  
 Email: John.Perkins@BobcatOfthebay.com

Customer  
**WEST BAY SANITARY DISTRICT**  
 500 LAUREL ST  
 MENLO PARK, CA, 94025-3427  
 Phone: +16504776416

Contact

Dealer  
**Bobcat of Fremont, Fremont, CA**

Item Name	Item Number	Quantity	Price Each	Total
<b>Felling Trailer</b>	FT-5	1	9,091.00	9,091.00
<b>Total for Felling Trailer</b>				<b>9,091.00</b>
Quote Total - USD				9,091.00
Sales total before Taxes				9,091.00
Taxes				897.74
<b>Quote Total - USD</b>				<b>9,988.74</b>

**Notes:**

PRICE DOES NOT INCLUDE LICENSING FEES, CUSTOMER RESPONSIBLE FOR DMV PAPERWORK

<b>Customer Acceptance:</b>	
Quotation Number: JP305753	Purchase Order: _____
<b>Authorized Signature:</b>	
Print: _____	Sign: _____
Date: _____	Email: _____ Tax Exempt: Y <input type="checkbox"/> / N <input type="checkbox"/>

**FT-5**

**Drop Deck Utility Series**

**GVWR LBS:**

**6,100**

**GAWR LBS:**

**5,080**

**WEIGHT LBS:**

**1,200**

**CAPACITY LBS:**

**4,900**

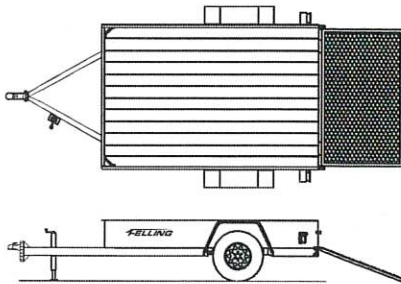

Standard & Other Options	Description	Std.	Option	Std. Qty.	Unit
Frame Type	Pan Style with 14" Sides	X		1.00	Std
Deck Length	Main Deck Length	X		12.00	Feet
Deck Type	Pressure Treated Wood	X		1.00	Std
Ramps; Rear	4' Full Width, Spring Assist Standard	X		1.00	Std
Appx Deck Height	14" Unloaded	X		1.00	Inches
Width	97" OD, 74" ID	X		1.00	Inches
Tie Downs	2 Corner Ties	X		2.00	Std
Tie Downs	1/2" D-Rings	X		6.00	Std
Brakes	Electric, Dexter FSA (Fwd Self Adj) On All Axles	X		1.00	Std
Axles	6K Dexter, Drop	X		1.00	Std
Suspension	Dexter Spring	X		1.00	Std
Tires & Wheels	ST225/75R 15 D, 6 Bolt [15 x 6] White Mod	X		2.00	Std
Hitch Length	Center of Coupler to Headboard, Appx	X		4.50	Feet
Hitch Type	2" Ball, [B] Adjustable, 10,000 lb Channel Mount	X		1.00	Std
Jack	7K Drop Leg ** Top Wind **	X		1.00	Std
Plug	7 Pole RV	X		1.00	Std
Lights	LED Lights (Peterson), Sealed Wiring Harness (Sealco)	X		1.00	Std
Trailer Color	Felling Black # CCA945378 (White Felling Decal)	X		1.00	Std
Stripe Color	White	X		1.00	Std
Standard	3/8" Safety Chains, Grade 70	X		1.00	Std
GVWR	6,100 lbs	X		1.00	Std

THIS PAGE LEFT INTENTIONALLY BLANK





**WEST BAY SANITARY DISTRICT  
AGENDA ITEM 7**

**To: Board of Directors**

**From: Sergio Ramirez, General Manager**

**Subject: Discussion and Direction on the West Bay and Sharon Heights Recycled Water Facility**

A discussion will be held on the Sharon Heights Recycled Water Facility and other events related to the recycled water plant. The Board will have the opportunity to provide direction to staff and legal counsel.

**Recycled Water Facility Production Data:**

<b>2020</b>	<b>Treated</b>	<b>Delivered</b>
August	8.8MG	8.2MG
September	8.2MG	5.1MG
October	7.4MG	4.5MG
November	5MG	1.4MG
December	4.7MG	.55MG
<b>2021</b>	<b>Treated</b>	<b>Delivered</b>
January	4.8MG	.23MG
February	4.4MG	.13MG
March	5.9MG	1.8MG
April	8.5MG	7.6MG
May	9.3.MG	8.2MG
June	9.8MG	8.7MG
July	9.5MG	9.1MG
August	9.4MG	9.0MG
September	9.1MG	6.9MG*
October	7.6MG	2.6MG**
November	5.2MG	0
December	4.7MG	0

<b>2022</b>	<b>Treated</b>	<b>Delivered</b>
January	4.4MG	97,000 gallons
February	4.4MG	1.5MG
March	6.6MG	3.5MG
April	7.6MG	3.8MG
May	9.2MG	7.4MG
June	9.8MG	8.7MG
July	9.6MG	8.1MG
August	9.2MG	8.1MG
September	8.6MG	6.7MG
October	7.9MG	4.6MG
November	5.9MG	310,000 gallons
December	5.4MG	154,690 gallons

<b>2023</b>	<b>Treated</b>	<b>Delivered</b>
January	5MG	0 gallons
February	3.3MG	0 gallons
March	3.5MG	0 gallons
April	4.9MG	32k gals. Dust Control
May	5.1MG	432k gals. Dust Control
June	4.8MG	456k gals. Dust Control
July	6.2MG	1.05MG Dust Control
August	8.1MG	2.7MG (+ 1.5 MG Dust Control)
September	8.4MG	4MG (+ 1.04 MG Dust Control)
October	9.6MG	7.4MG
November	7.7MG	3.7MG
December	7.4MG	970K

<b>2024</b>	<b>Treated</b>	<b>Delivered</b>
January	5.8MG	175K gallons

\* Sharon Heights substantially tapered off their water usage for September which is the reason for the large discrepancy between treated and delivered.

\*\* Treatment was reduced in the second half of the month. Rain in late October and an irrigation equipment malfunctions caused water delivery to decrease.

*The following is a disclosure statement required for any document, written report or brochure prepared in whole or in part pursuant to the Finance Agreement with the State Water Resources Control Board for the West Bay Sanitary District Recycled Water Project - Sharon Heights: Funding for this project has been provided in full or in part through an agreement with the State Water Resources Control Board. California's Clean Water State Revolving Fund is capitalized through a variety of funding sources, including grants from the United States Environmental Protection Agency and state bond proceeds. The contents of this document do not necessarily reflect the views and policies of the foregoing, nor does mention of trade names or commercial products constitute endorsement or recommendation for use.*



**WEST BAY SANITARY DISTRICT  
AGENDA ITEM 8**

**To:            *Board of Directors***

**From:         *Sergio Ramirez, General Manager***

**Subject:      *Discussion and Direction on the Bayfront Recycled Water Project  
and Status Update***

---

A discussion will be held on the District's Bayfront Recycled Water Projects and other events related to the recycled water projects including financing, environmental review, design/build issues and grant applications.

The Board will have the opportunity to provide direction to staff and general counsel.

THIS PAGE LEFT INTENTIONALLY BLANK



**WEST BAY SANITARY DISTRICT  
AGENDA ITEM 9**

**To: Board of Directors**

**From: Sergio Ramirez, General Manager**

**Subject: Report, Discussion, and Direction on South Bayside Waste Management Authority (SBWMA) including the Solid Waste Franchise Re-Assignment**

---

The District's representative to South Bayside Waste Management Authority (SBWMA), President Fran Dehn, will report on any pertinent items regarding SBWMA business. General Manager Ramirez will report and seek direction on the solid waste franchise re-assignment.

THIS PAGE LEFT INTENTIONALLY BLANK



**WEST BAY SANITARY DISTRICT  
AGENDA ITEM 10**

**To:            *Board of Directors***

**From:         *Sergio Ramirez, General Manager***

**Subject:      *Report and Discussion on Silicon Valley Clean Water (SVCW)  
Plant***

---

The District's representative to Silicon Valley Clean Water (SVCW), Commissioner George Otte, will report on pertinent items regarding SVCW Operations, CIP and Finance.

---

**Report to the District Board for the Regular Meeting of February 14, 2024**

THIS PAGE LEFT INTENTIONALLY BLANK